

# RFB

## Retrofit Bolt

The RFB retrofit bolt is a clean, oil-free, pre-cut threaded rod, supplied with nut and washer. It offers a complete engineered anchoring system when used with Simpson Strong-Tie® adhesive. Inspection is easy; the head is stamped with rod length and “No Equal” symbol for identification after installation.

**Material:** ASTM F1554 Grade 36

**Finish:** Zinc plated (unless otherwise noted), available in HDG (per ASTM A153)

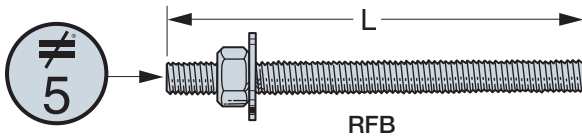

For more information on corrosion protection, see p. 14.

Size (in.)	Zinc-Plated Model No.	Hot-Dip Galvanized Model No.
1/2 x 4	RFB#4X4	—
1/2 x 5	RFB#4X5	RFB#4X5HDG
1/2 x 6	RFB#4X6	RFB#4X6HDG
1/2 x 7	RFB#4X7	RFB#4X7HDG
1/2 x 8	—	RFB#4X8HDG
1/2 x 10	RFB#4X10	RFB#4X10HDG
5/8 x 5	RFB#5X5	RFB#5X5HDG
5/8 x 8	RFB#5X8	RFB#5X8HDG
5/8 x 10	RFB#5X10	RFB#5X10HDG
5/8 x 12	—	RFB#5X12HDG
5/8 x 16	RFB#5X16	RFB#5X16HDG
3/4 x 10 1/2	RFB#6X10.5	RFB#6X10.5HDG

1. Washer and nut provided on all RFBs.

# CNW/HSCNW

## Coupler Nuts

Simpson Strong-Tie coupler nuts are a tested and load-rated method to join threaded rod and anchor bolts. The Witness® Holes in each nut provides a means to verify when rods are properly installed. The positive stop feature helps ensure even threading into each end of the nut. The CNW exceeds the specified minimum tensile capacity of corresponding ASTM A36 bolts and threaded rod. The HSCNW exceeds the specified minimum tensile capacity of corresponding ASTM A449 bolts and threaded rod. Contact Simpson Strong-Tie for other coupler nut sizes.

**Finish:** Zinc plated

**Installation:**

- Tighten the two rods until each all-thread rod is visible in the Witness Hole. Any portion of thread visible in the Witness Hole is a correct installation.
- Standard CNW for use with non-hot-dip galvanized all-thread rod only.
- 5/8"- and 7/8"-diameter couplers available with oversized threads for installation to hot-dip galvanized bolts (order CNW5/8-5/8-OST and CNW7/8-7/8-OST).
- OST couplers are typically oversized on one end of the coupler nut only and will be marked with an “O” on oversized side.  
*Couplers may be special ordered with both ends oversized.*  
Contact Simpson Strong-Tie to order.

**Codes:** See p. 11 for Code Reference Key Chart

Model No.	Rod Diameter (in.)	H Min. (in.)	Allowable Tension Load	Code Ref.
			(100)	
CNW1/2	1/2	1 1/4	4,265	IBC, FL
CNW5/8	5/8	1 1/2	6,675	
CNW3/4	3/4	1 3/4	9,610	
CNW7/8	7/8	2	13,080	
CNW1	1	2 1/4	17,080	—
CNW1-1/4	1 1/8	2 3/4	26,690	
HSCNW3/4	3/4	1 3/4	19,880	—
HSCNW1	1	2 1/4	35,345	
Transition Couplers				
CNW5/8-1/2	5/8 to 1/2	1 3/8	4,265	IBC, FL
CNW3/4-5/8	3/4 to 5/8	1 5/8	6,675	
CNW7/8-5/8	7/8 to 5/8	1 3/4	6,675	—
CNW1-7/8	1 to 7/8	2 1/8	13,080	

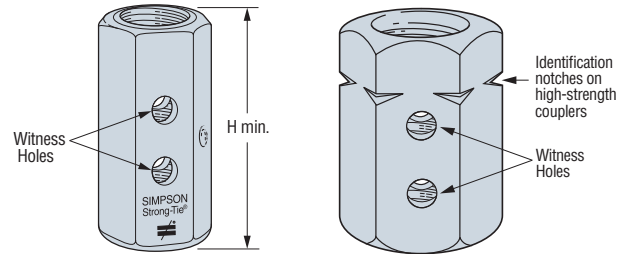

**CNW**  
Allows Fast Visual Check for Correct All Thread Rod Installation

**HSCNW**  
High-Strength Coupler Nut

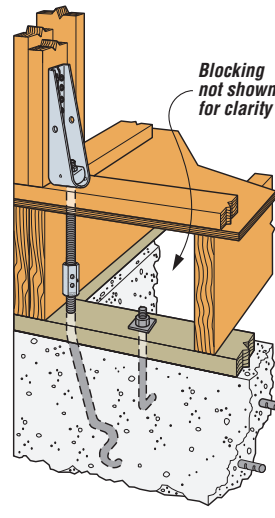

**Typical CNW**  
Rim Board Installation

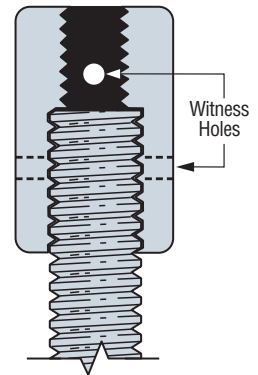

**CNW**  
Transition Coupler Nut

1. Allowable loads shown are based on AISC 360 for A36 and A449 (HS) threaded rods.

# CNW Coupler Nuts

Simpson Strong-Tie® coupler nuts are a tested and load-rated method to join threaded rod and anchor bolts. “Witness” holes in the nut provide a means to verify when rods are properly installed. The positive stop feature helps ensure even threading into each end of the nut. CNWs meet and exceed the specified minimum tensile capacity of corresponding ASTM A36 bolts and threaded rod. HSCNWs meet and exceed the specified minimum tensile capacity of corresponding ASTM A449 bolts and threaded rod. Contact Simpson Strong-Tie for other coupler nut sizes.

**Finish:** Zinc Plated

**Installation:**

- Tighten the two rods until each all-thread rod is visible in the witness hole. Any portion of the thread visible in the witness is a correct installation.
- Standard CNW for use with non-hot-dip galvanized all-thread rod only.
- 5/8" and 7/8" diameter couplers available with oversized threads for installation to hot-dip galvanized bolts (order CNW5/8-5/8OST and CNW7/8-7/8OST). Note that only one side is oversized to accommodate HDG rods and bolts.
- Some OST couplers are typically oversized on one end of the coupler nut only and will be marked with an “O” on the oversized side. Couplers may be oversized on both ends. Contact Simpson Strong-Tie.

**Codes:** See p. 11 for Code Reference Key Chart

Model No.	Rod Diameter (in.)	H Min. (in.)	Allowable Tension Capacity (lb.)	Code Ref.
			(100)	
CNW1/2	0.500	1 1/2	4,265	IBC, FL
CNW5/8	0.625	1 7/8	6,675	
CNW3/4	0.750	2 1/4	9,610	
CNW7/8	0.875	2 1/2	13,080	
CNW1	1.000	2 3/4	17,080	—
CNW1 1/4	1.250	3	26,690	
HSCNW3/4	0.750	2 1/4	19,880	—
HSCNW1	1.000	2 3/4	35,345	
Transition Couplers				
CNW5/8 - 1/2	0.625 to 0.500	1 1/2	4,265	IBC, FL
CNW3/4 - 5/8	0.750 to 0.625	1 3/4	6,675	
CNW7/8 - 5/8	0.875 to 0.625	2	6,675	—
CNW1 - 7/8	1.000 to 0.875	2 1/4	13,080	

1. Allowable loads shown are based on AISC 14th Edition A36 and A449 (HS) threaded rod capacities.

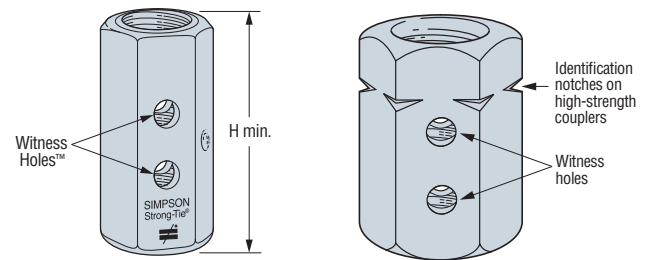

**CNW**  
Allows Fast Visual Check for Correct All Thread Rod Installation

**HSCNW**  
High-Strength Coupler Nut

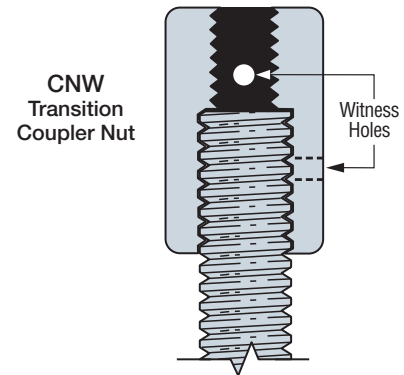

**CNW**  
Transition Coupler Nut

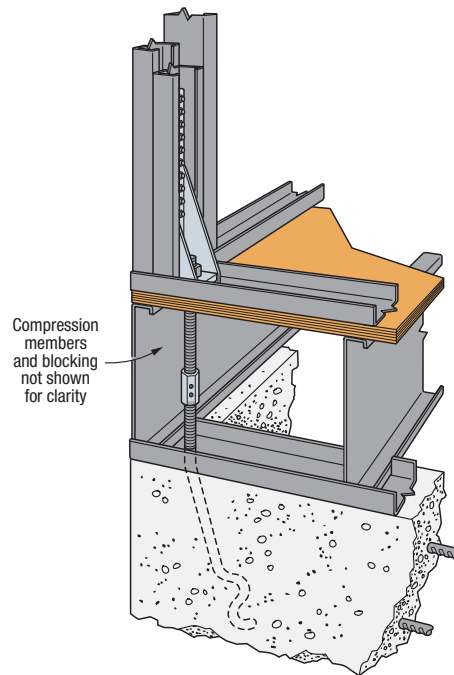

**Typical CNW Rim Joist Installation**