

# HANGERS & ELECTRICAL ACCESSORIES

25#/Cpc

Design Load = 250#

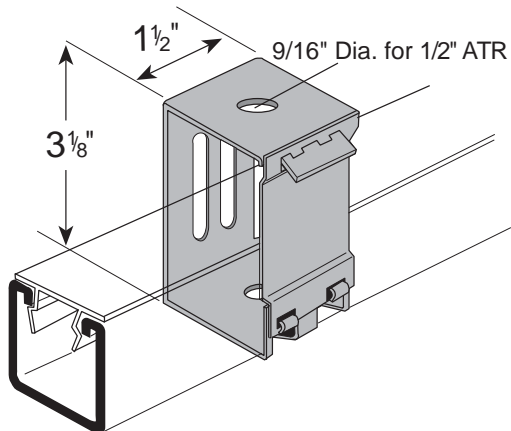

**FS-6420**  
CHANNEL HANGER

4#/Cpc

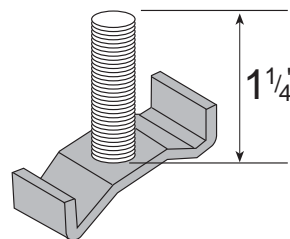

**FS-6460**  
FIXTURE STUD NUT

2#/Cpc

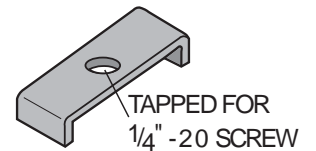

**FS-6461**  
FIXTURE NUT

27#/Cpc

Design Load = 150#

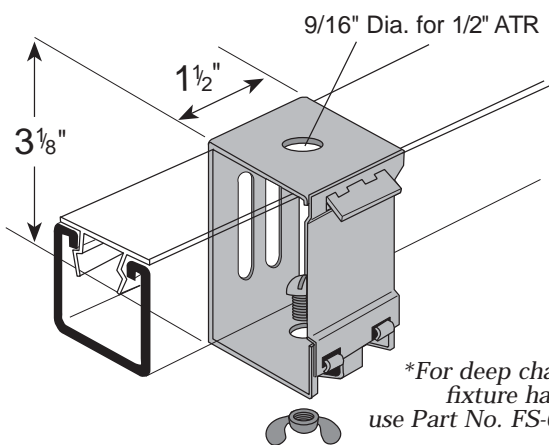

**FS-6422**  
FIXTURE HANGERS

*\*For deep channel fixture hanger, use Part No. FS-6426*

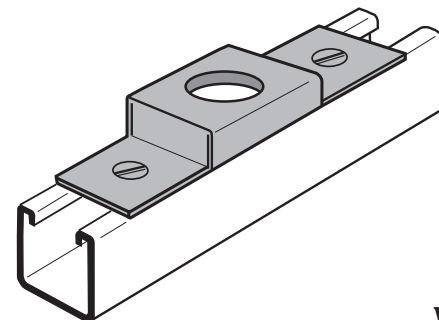

Cat. No.	Use With	Hole	Weight Lbs./C
FS-6442	1/2" Conduit	7/8"	28
FS-6443	3/4" Conduit	1-3/32"	28

Assembly includes Strut Nuts and Flat Head Machine Screws

**FS-6442**  
CONDUIT CONNECTOR

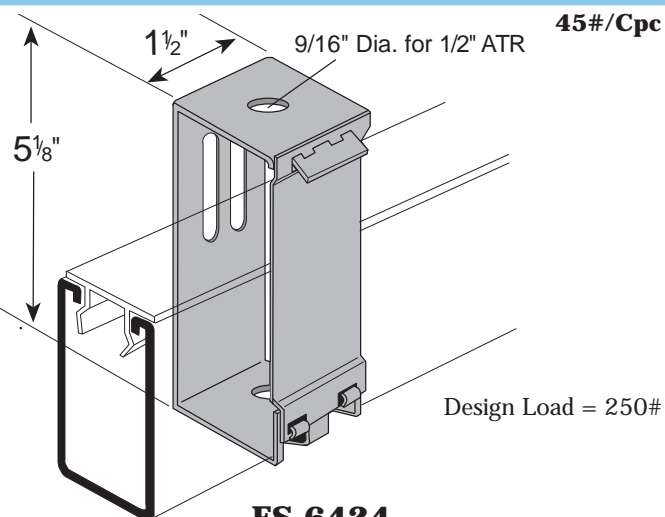

**FS-6424**  
DEEP CHANNEL HANGER

Design Load = 250#

45#/Cpc

8#/Cpc

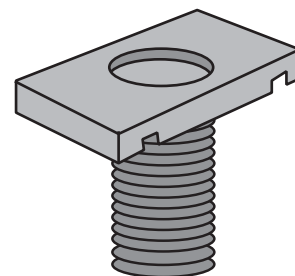

**FS-6462**  
WIRING STUD NUT

# HANGERS & ELECTRICAL ACCESSORIES

Includes (4) 1/4" -20  
Hex Nuts

**134#/Cpc**

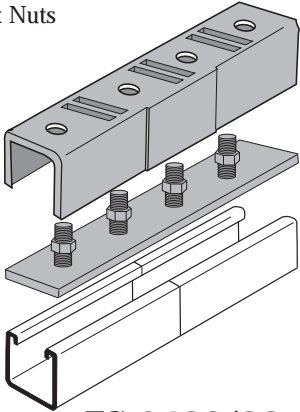

**FS-6432/39**

**INCLUDES**

- FS-6432-SPLICE CLEVIS
- FS-6439 STUD PLATE

Includes (4) 1/4" -20  
Flathead Screws

**132#/Cpc**

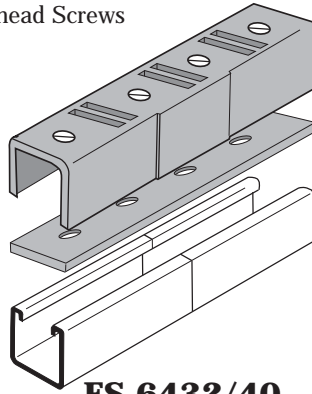

**FS-6432/40**

**INCLUDES**

- FS-6432-SPLICE CLEVIS
- 1/4" -20FHMS
- FS-6440 TAPPED PLATE

**For FS-200 Channel**

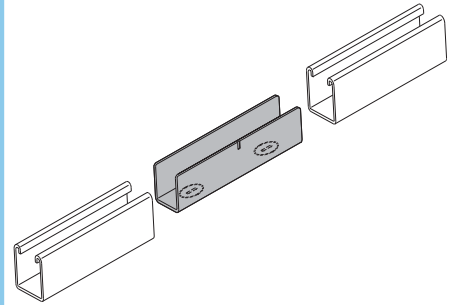

**FS-6441**

**IN-LINE STRUT JOINER**

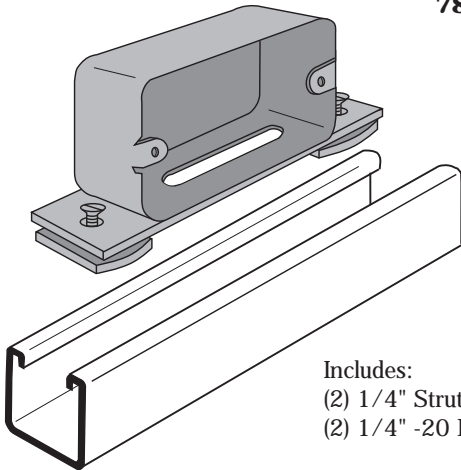

**78#/Cpc**

**FS-6445  
OUTLET BOX**

Includes:  
(2) 1/4" Strut Nuts  
(2) 1/4" -20 FHMS

## SWIVEL HANGERS

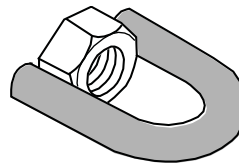

**FS-6471-3/8  
FS-6471-1/2**

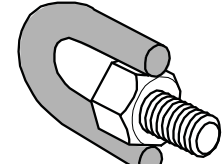

**FS-6481-3/8  
FS-6481-1/2**

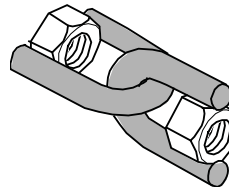

**FS-6472-3/8  
FS-6472-1/2**

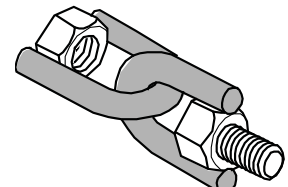

**FS-6482-3/8  
FS-6482-1/2**

19 Ga. (.040) Steel and Aluminum  
Finish: Plain / Green / Galvanized / Aluminum

**47#/Cft**

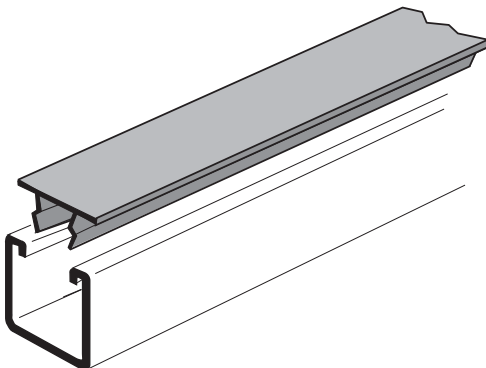

**FS-6500  
CLOSURE STRIP (ELECTRICAL COVER)  
STEEL OR ALUMINUM**

Plastic Available In:  
Black / White / Green / Gray

**8#/Cft**

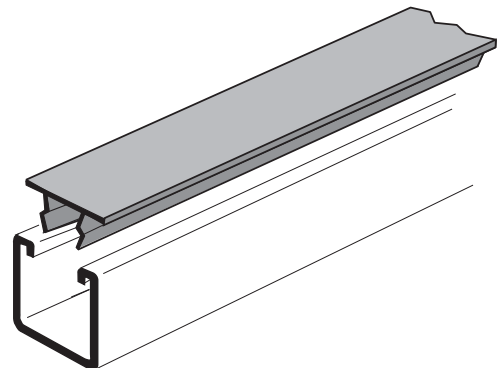

**FS-6518  
CLOSURE STRIP  
PLASTIC**