

Hollow Drop-In Internally Threaded Anchor

The Simpson Strong-Tie® Hollow Drop-In Anchor (HDIA) is an internally threaded, flush-mount expansion anchor for use in hollow materials such as CMU and hollow-core plank, as well as in solid base materials such as brick, normal-weight and lightweight concrete.

Features:

- Suitable for suspending conduit, cable trays, pipe supports, fire sprinklers and suspended lighting into concrete
- Expansion design allows HDIA to anchor into CMU, hollow-core plank, brick, normal-weight concrete and lightweight concrete
- Internally threaded anchor allows for easy bolt removal

Material: Die-cast Zamac 3 alloy shell with carbon-steel cone or 304 stainless-steel cone

Codes: Factory Mutual 3053987 (3/8"–1/2" diameter)
Underwriters Laboratories EX3605 (3/8"–1/2" diameter)



Hollow Drop-In

Hollow Drop-In Anchor

Size (in.)	Model No.	Drill Bit Diameter (in.)	Threads (per in.)	Overall Anchor Length (in.)	Quantity	
					Package Qty.	Carton Qty.
1/4	HDIA25	3/8	20	3/4	100	1,600
1/4	HDIA25SS	3/8	20	3/4	100	1,600
5/16	HDIA31	5/8	18	1 1/4	50	200
3/8	HDIA37	5/8	16	1 1/4	50	200
3/8	HDIA37SS	5/8	16	1 1/4	50	200
1/2	HDIA50	3/4	13	1 3/4	50	250
5/8	HDIA62	1	11	2	25	125

HDIASTH Setting Tool for Hollow Materials

Setting tool designed to set the Hollow Drop-In internally threaded anchor in hollow materials such as CMU and hollow-core plank.

Model No.	Description	Size (in.)	Carton Qty.
HDIASTH25	Setting tool for use with Hollow Drop-In models HDIA25, HDIA25SS	1/4	25
HDIASTH31	Setting tool for use with Hollow Drop-In model HDIA31	5/16	25
HDIASTH37	Setting tool for use with Hollow Drop-In models HDIA37, HDIA37SS	3/8	25
HDIASTH50	Setting tool for use with Hollow Drop-In model HDIA50	1/2	25
HDIASTH62	Setting tool for use with Hollow Drop-In model HDIA62	5/8	10

1. Tools sold separately. Tools may be ordered by the piece.



HDIASTH Setting Tool

HDIASTS Setting Tool for Solid Materials

Setting tool designed to set the Hollow Drop-In internally threaded anchor in solid materials such as brick, normal-weight and lightweight concrete.

Model No.	Description	Size (in.)	Box Qty.	Carton Qty.
HDIASTS25	Setting tool for use with Hollow Drop-In models HDIA25, HDIA25SS	1/4	25	125
HDIASTS31-37	Setting tool for use with Hollow Drop-In models HDIA31, HDIA37, HDIA37SS	5/16 – 3/8	10	50
HDIASTS50	Setting tool for use with Hollow Drop-In model HDIA50	1/2	10	50
HDIASTS62	Setting tool for use with Hollow Drop-In model HDIA62	5/8	5	20

1. Tools sold separately. Tools may be ordered by the piece.

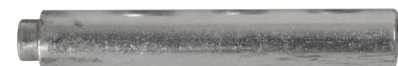

HDIASTS Setting Tool

Hollow Drop-In Internally Threaded Anchor

Installation Instructions — Solid Base (using solid setting tool)

- Drill a hole in the base material using the appropriate diameter carbide drill bit as specified in the table. Drill the hole to the specified embedment depth.
- Blow the hole clean using compressed air. Overhead installations need not be blown clean.
- Insert the HDIA into hole. Tap with hammer until flush against surface.
- Using the designated setting tool, drive the anchor to the bottom of the drilled hole. After the anchor reaches the bottom of the drilled hole, perform an additional 3 hammer blows against the setting tool to drive the anchor body over the cone.
- Position fixture; insert fastener and tighten.

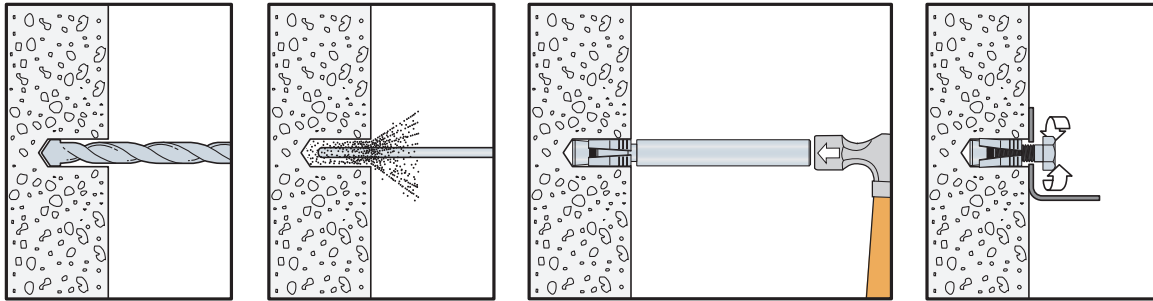

Installation Instructions — Hollow Base (using hollow setting tool)

- Drill a hole in the base material using the appropriate diameter carbide drill bit as specified in the table.
- Thread the HDIA onto the designated setting tool for hollow base materials.
- Insert the HDIA into the hole. Tap the setting tool until the face of the tool contacts the surface.
- Rotate the setting tool a minimum of 2 turns to set the anchor.
- Remove the setting tool.
- Position fixture; insert fastener and tighten.

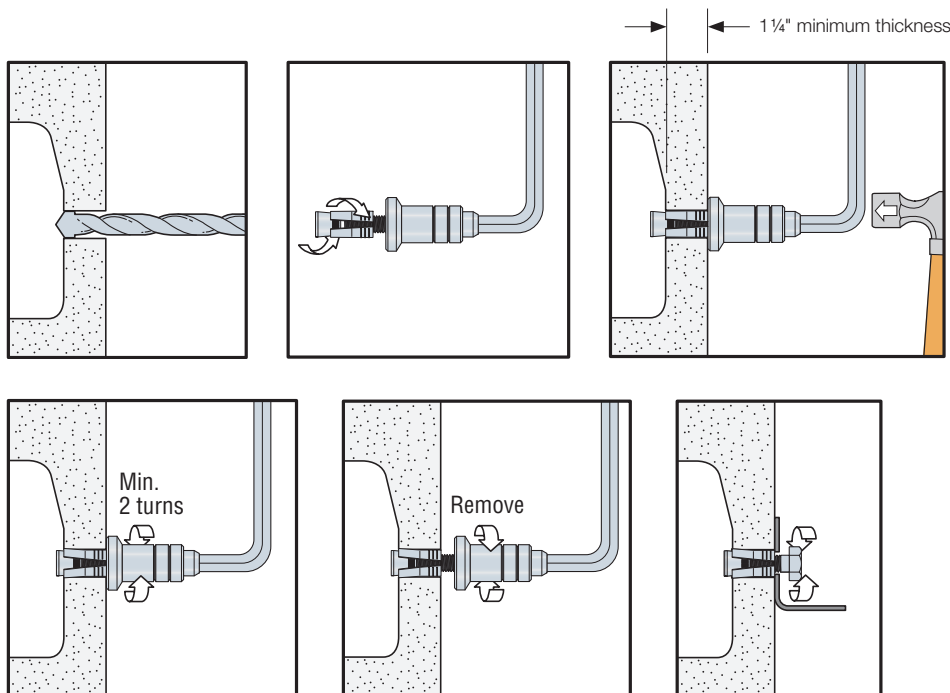

Hollow Drop-In Design Information — Concrete and Masonry

Allowable Tension Loads for Hollow Drop-In Anchor
in Normal-Weight Concrete

Model No.	Size in. (mm)	Drill Bit Dia. in. (mm)	Embed Depth in. (mm)	Critical Edge Dist. in. (mm)	Critical Spacing in. (mm)	Tension Load			
						$f'_c \geq 2,500$ psi (17.2 MPa)		$f'_c \geq 4,000$ psi (27.6 MPa)	
						Ultimate lb. (kN)	Allowable lb. (kN)	Ultimate lb. (kN)	Allowable lb. (kN)
HDIA25, HDIA25SS	1/4 (6.4)	3/8 (9.5)	7/8 (22)	2 5/8 (67)	3 1/2 (89)	1,180 (5.2)	295 (1.3)	1,220 (5.4)	305 (1.4)
HDIA31	5/16 (7.9)	5/8 (15.9)	1 1/2 (38)	4 1/2 (114)	6 (152)	3,000 (13.3)	750 (3.3)	3,420 (15.2)	855 (3.8)
HDIA37, HDIA37SS	3/8 (9.5)	5/8 (15.9)	1 1/2 (38)	4 1/2 (114)	6 (152)	3,000 (13.3)	750 (3.3)	3,420 (15.2)	855 (3.8)
HDIA50	1/2 (12.7)	3/4 (19.1)	2 (51)	6 (152)	8 (203)	4,260 (18.9)	1,065 (4.7)	5,500 (24.5)	1,375 (6.1)
HDIA62	5/8 (15.9)	1 (25.4)	2 1/4 (57)	6 3/4 (171)	9 (229)	6,100 (27.1)	1,525 (6.8)	6,300 (28.0)	1,575 (7.0)

1. The allowable loads listed are based on a safety factor of 4.0.
2. The minimum concrete thickness is 1 1/2 times the embedment depth.
3. Allowable loads may be linearly interpolated between concrete strengths listed.

Allowable Shear Loads for Hollow Drop-In Anchor
in Normal-Weight Concrete

Model No.	Size in. (mm)	Drill Bit Dia. in. (mm)	Embed Depth in. (mm)	Critical Edge Dist. in. (mm)	Critical Spacing in. (mm)	Shear Load Based on Anchor Strength		Shear Load Based on Steel Strength	
						$f'_c \geq 2,500$ psi (17.2 MPa)		F1554 Grade 36	A193 Grade B7
						Ultimate lb. (kN)	Allowable lb. (kN)	Allowable lb. (kN)	Allowable lb. (kN)
HDIA25, HDIA25SS	1/4 (6.4)	3/8 (9.5)	7/8 (22)	2 5/8 (67)	3 1/2 (89)	1,840 (8.2)	460 (2.0)	485 (2.2)	1,045 (4.6)
HDIA31	5/16 (7.9)	5/8 (15.9)	1 1/2 (38)	4 1/2 (114)	6 (152)	2,660 (11.8)	665 (3.0)	755 (3.4)	1,630 (7.3)
HDIA37, HDIA37SS	3/8 (9.5)	5/8 (15.9)	1 1/2 (38)	4 1/2 (114)	6 (152)	3,580 (15.9)	895 (4.0)	1,085 (4.8)	2,340 (10.4)
HDIA50	1/2 (12.7)	3/4 (19.1)	2 (51)	6 (152)	8 (203)	8,220 (36.6)	2,055 (9.1)	1,930 (8.6)	4,160 (18.5)
HDIA62	5/8 (15.9)	1 (25.4)	2 1/4 (57)	6 3/4 (171)	9 (229)	10,180 (45.3)	2,545 (11.3)	3,025 (13.5)	6,520 (29.0)

1. The allowable loads listed are based on a safety factor of 4.0.
2. The minimum concrete thickness is 1 1/2 times the embedment depth.
3. Allowable load must be the lesser of the load based on anchor strength or steel strength.

Hollow Drop-In Design Information — Concrete and Masonry

Allowable Tension and Shear Loads for Hollow Drop-In Anchor in 8" Lightweight, Medium-Weight and Normal-Weight Hollow CMU



Model No.	Size in. (mm)	Drill Bit Dia. in. (mm)	Embed Depth ⁴ in. (mm)	Minimum Edge Dist. in. (mm)	Minimum End Dist. in. (mm)	Minimum Spacing in. (mm)	Tension Load		Shear Load	
							Ultimate lb. (kN)	Allowable lb. (kN)	Ultimate lb. (kN)	Allowable lb. (kN)
HDIA25, HDIA25SS	¼ (6.4)	¾ (9.5)	¾ (19)	4 (102)	4½ (117)	8 (203)	500 (2.2)	100 (0.4)	975 (4.3)	195 (0.9)
HDIA31	⅝ (7.9)	¾ (15.9)	1¼ (32)	4 (102)	4½ (117)	8 (203)	500 (2.2)	100 (0.4)	1,450 (6.4)	290 (1.3)
HDIA37, HDIA37SS	¾ (9.5)	¾ (15.9)	1¼ (32)	4 (102)	4½ (117)	8 (203)	500 (2.2)	100 (0.4)	1,450 (6.4)	290 (1.3)
HDIA50	½ (12.7)	¾ (19.1)	1¼ (44)	4 (102)	4½ (117)	8 (203)	1,525 (6.8)	305 (1.4)	2,300 (10.2)	460 (2.0)
HDIA62	⅝ (15.9)	1 (25.4)	2 (51)	4 (102)	4½ (117)	8 (203)	1,525 (6.8)	305 (1.4)	2,325 (10.3)	465 (2.1)

1. The allowable loads listed are based on a safety factor of 5.0.
2. Values for 8-inch wide lightweight, medium-weight, and normal-weight CMU.
3. The minimum specified compressive strength of masonry, f_m , at 28 days with a minimum face shell thickness of 1¼" is 1,500 psi.
4. The installed end of the anchor may extend into the CMU cavity depending upon face shell thickness.

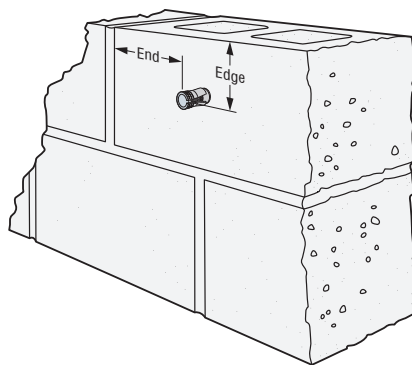

Mechanical Anchors

Tension and Shear Loads for Hollow Drop-In Anchor in Hollow-Core Concrete Panel



Model No.	Size in. (mm)	Drill Bit Dia. in. (mm)	Embed Depth ⁴ in. (mm)	Critical Edge Dist. in. (mm)	Critical Spacing in. (mm)	Tension Load		Shear Load Based on Anchor Strength		Shear Load Based on Steel Strength of Threaded Rod	
						$f'_c \geq 5,000$ psi (34.5 MPa)		$f'_c \geq 5,000$ psi (34.5 MPa)		F1554 Grade 36	A193 Grade B7
						Ultimate lb. (kN)	Allowable lb. (kN)	Ultimate lb. (kN)	Allowable lb. (kN)	Allowable lb. (kN)	Allowable lb. (kN)
HDIA25, HDIA25SS	¼ (6.4)	¾ (9.5)	¾ (19)	3 (76)	4½ (114)	1,340 (6.0)	335 (1.5)	2,040 (9.1)	510 (2.3)	485 (2.2)	1,045 (4.6)
HDIA31	⅝ (7.9)	¾ (15.9)	1¼ (32)	5 (127)	7½ (191)	1,820 (8.1)	455 (2.0)	3,240 (14.4)	810 (3.6)	755 (3.4)	1,630 (7.3)
HDIA37, HDIA37SS	¾ (9.5)	¾ (15.9)	1¼ (32)	5 (127)	7½ (191)	1,820 (8.1)	455 (2.0)	4,560 (20.3)	1,140 (5.1)	1,085 (4.8)	2,340 (10.4)
HDIA50	½ (12.7)	¾ (19.1)	1¼ (44)	7 (178)	10½ (267)	2,840 (12.6)	710 (3.2)	5,820 (25.9)	1,455 (6.5)	1,930 (8.6)	4,160 (18.5)
HDIA62	⅝ (15.9)	1 (25.4)	2 (51)	8 (203)	12 (305)	2,980 (13.3)	745 (3.3)	8,700 (38.7)	2,175 (9.7)	3,025 (13.5)	6,520 (29.0)

1. The allowable loads listed are based on a safety factor of 4.0.
2. The minimum concrete thickness over the open cores is 1¼".
3. The minimum specified compressive strength of the concrete used in the hollow-core panel, f'_c , is 5,000 psi (34.5 MPa).
4. The installed end of the anchor may extend into the panel cavity depending upon face shell thickness.

C-A-2021 © 2021 SIMPSON STRONG-TIE COMPANY INC.

* See p. 12 for an explanation of the load table icons.