

LTP4/LTP5/A34/A35

Framing Angles and Plates

The larger LTP5 spans subfloor at the top of the blocking or rim board. The embossments enhance performance.

The LTP4 lateral tie plate transfers shear forces for top plate-to-rim board or blocking connections. Nail holes are spaced to prevent wood splitting for single and double top-plate applications. May be installed over plywood sheathing.

The A35 angle's exclusive bending slot allows instant, accurate field bends for all two- and three-way ties. Balanced, completely reversible design permits the A35 to secure a great variety of connections.

Material: LTP4/LTP5 — 20 gauge; all others — 18 gauge

Finish: Galvanized. Some products available in stainless steel or ZMAX® coating. See Corrosion Information, pp. 12–15.

Installation:

- Use all specified fasteners; see General Notes
- A35 — Bend one time only

Codes: See p. 11 for Code Reference Key Chart

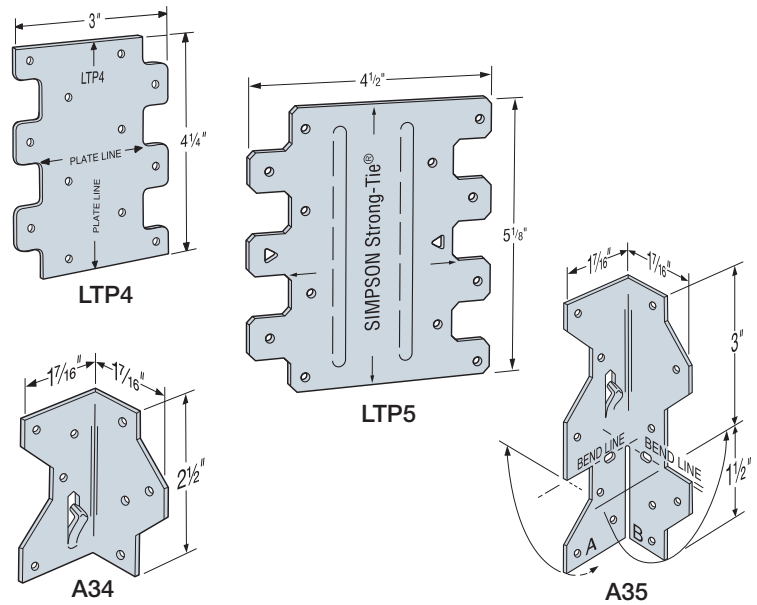

Straps and Ties

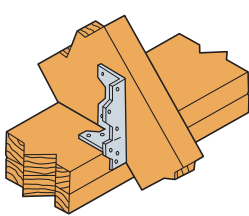

Joists to Plate with A Leg Inside

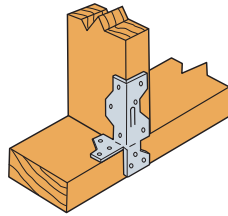

Studs to Plate with B Leg Outside

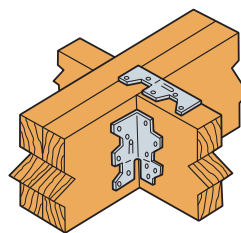

Joists to Beams

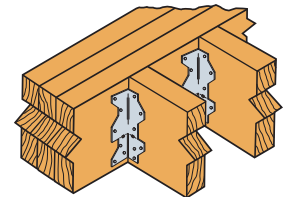

Ceiling Joists to Beam

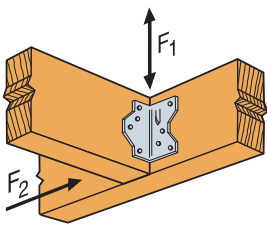

1 A34

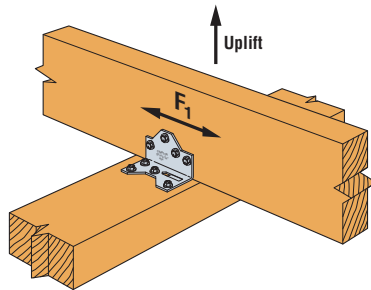

1 A34 Installed with SD Screws

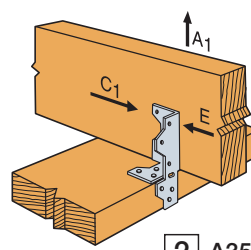

2 A35

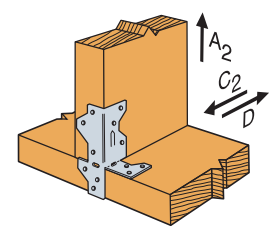

3 A35

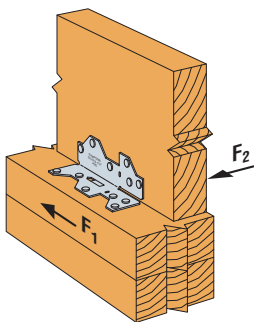

4 A35

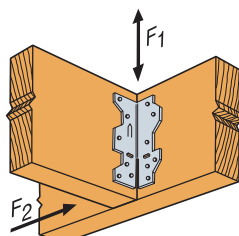

4 A35

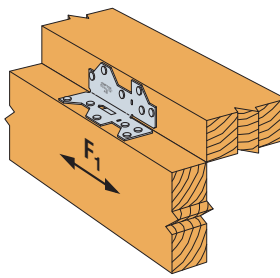

5 A35

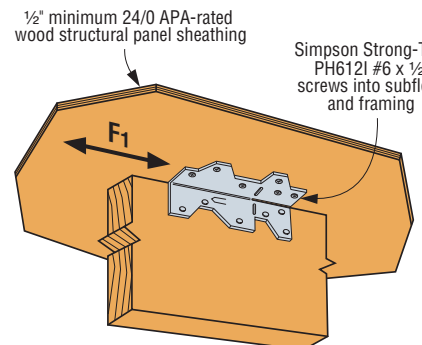

6 A35

LTP4/LTP5/A34/A35

Framing Angles and Plates (cont.)

These products are available with additional corrosion protection. For more information, see p. 14.

SS For stainless-steel fasteners, see p. 21.

SD Many of these products are approved for installation with Strong-Drive® SD Connector screws. See pp. 348–352 for more information.

Model No.	Type of Connection	Fasteners (in.)	Direction of Load	DF/SP Allowable Loads			SPF/HF Allowable Loads			Code Ref.	
				Floor (100)	Roof (125)	(160)	Floor (100)	Roof (125)	(160)		
SS A34	1	(8) 0.131 x 1 1/2	F ₁	395	480	545	340	415	480	IBC, FL, LA	
			F ₂ ⁶	395	430	430	340	370	370		
		(8) #9 x 1 1/2" SD	F ₁	640	640	640	550	550	550	—	
			F ₂	495	495	495	425	425	425		
			Uplift	240	240	240	170	170	170		
SS A35	2	(9) 0.131 x 1 1/2	A ₁	295	350	350	255	300	300	IBC, FL, LA	
			E	295	360	385	255	310	330		
			C ₁	185	185	185	160	160	160		
	3	(12) 0.131 x 1 1/2	A ₂	295	325	325	255	280	280		
			C ₂	295	330	330	255	285	285		
	4	(12) 0.131 x 1 1/2	F ₁	590	650	650	510	560	560		
			F ₂ ⁶	590	670	670	510	575	575		
	5	(12) 0.131 x 1 1/2	F ₁	555	555	555	475	475	475		
	6	(12) PH612I	F ₁	420	420	420	360	360	360		—
	LTP4	7	(12) 0.131 x 1 1/2	G	580	715	715	500	615		615
H				525	525	525	450	450	450		
LTP5	8	(12) 0.131 x 1 1/2	G	565	565	565	485	485	485		
			H	490	490	490	420	420	420		

- Allowable loads are for one angle. When angles are installed on each side of the joist, the minimum joist thickness is 3".
- Some illustrations show connections that could cause cross-grain tension or bending of the wood during loading if not reinforced sufficiently. In this case, mechanical reinforcement should be considered.
- LTP4 can be installed over 3/8" wood structural panel sheathing with 0.131" x 1 1/2" nails and achieve 0.72 of the listed load, or over 1/2" sheathing and achieve 0.64 of the listed load. 0.131" x 2 1/2" nails will achieve 100% load.
- LTP4 satisfies the IRC continuously sheathed portal frame (CS-PF) framing anchor requirements when installed over raised wood floor framing per Figure R602.10.6.4.
- The LTP5 may be installed over wood structural panel sheathing up to 1/2" thick using 0.131" x 1 1/2" nails with no reduction in load.
- Connectors are required on both sides to achieve F₂ loads in both directions.
- A34 and A35 installed with 0.131" x 1 1/2" nails onto 1 1/4" LSL material will achieve 0.90 of the listed F₁ and F₂ loads.
- Fasteners:** Nail dimensions are listed diameter by length. SD screws are Simpson Strong-Tie® Strong-Drive® SD Connector screws. PH612I is a pan-head #6 x 1 1/2" screw available from Simpson Strong-Tie. See pp. 21–22 for other nail sizes and information.

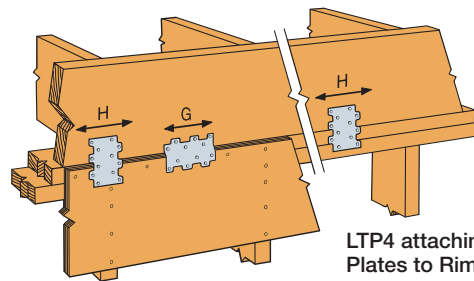

LTP4 attaching Top Plates to Rim Board

7 LTP4 Installed over Wood Structural Panel Sheathing

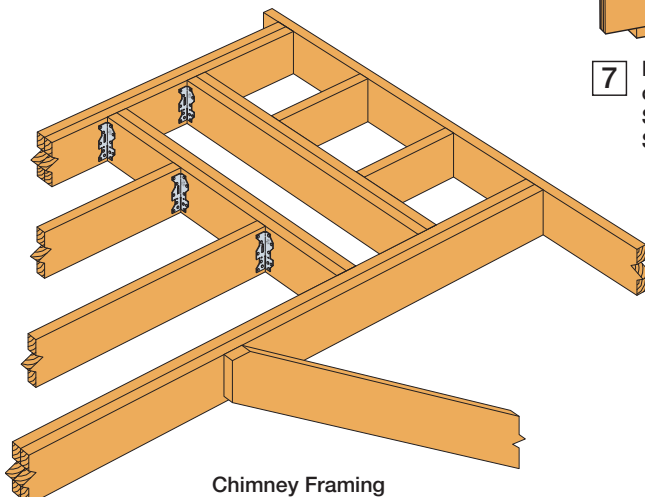

Chimney Framing

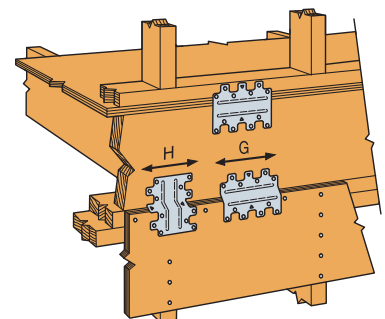

8 LTP5 Installed over Wood Structural Panel Sheathing or Attaching Plate to Rim Board