

LTT/HTT

Tension Ties

Holdowns and Tension Ties

Tension ties offer a solution for resisting tension loads that are fastened with nails or Strong-Drive® SD Connector screws. The new LTT2 light tension tie, designed for wood joist attachments to concrete or masonry walls, features two separate nailing patterns: obround holes spaced 3" apart for I-joist purlins and square holes spaced to accommodate the narrow face of 2x solid-sawn purlins. LTT2 may also be installed vertically on the wide face of a minimum 2x4 stud for holddown application. It features an extruded anchor bolt hole to accommodate 3/4", 5/8" and 1/2" bolt diameters.

The LTTI31 is designed for wood chord open-web truss attachments to concrete or masonry walls and may also be installed vertically on a minimum 2x6 stud.

The HTT4 and HTT5 tension ties feature an optimized nailing pattern which results in better performance with less deflection. HTT5KT is sold as a kit with the holddown, bearing plate washer and Strong-Drive SD Connector screws.

The HTT5-3/4 is designed to use a 3/4"-diameter anchor bolt.

When using LTT or HTT tension ties with unreinforced concrete masonry, 3/4" post-installed anchor bolts are commonly used.

Material: See table

Finish: Galvanized. May be ordered HDG; contact Simpson Strong-Tie.

Installation:

- See Holddown and Tension Tie General Notes on pp. 49–50.
- LTT2 — one standard cut-washer is required when using 1/2" and 5/8" anchor bolts; and no additional washer is required for 3/4" anchor bolts.
- LTT2 — For installations on narrow edge of solid sawn (2x, 3x) joists use (15) square holes; for all other installations use (12) obround holes.
- For tension ties installed over wood structural panel sheathing, use a 2 1/2"-long fastener minimum.
- For information about marriage strap at panelized roof applications, see strongtie.com.
- HTT5-KT requires BP 5/8-2 bearing plate and #10 x 2 1/2" SD Strong-Drive screws (included in kit).

Codes: See p. 11 for Code Reference Key Chart

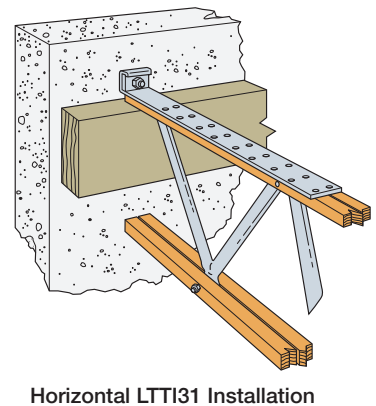
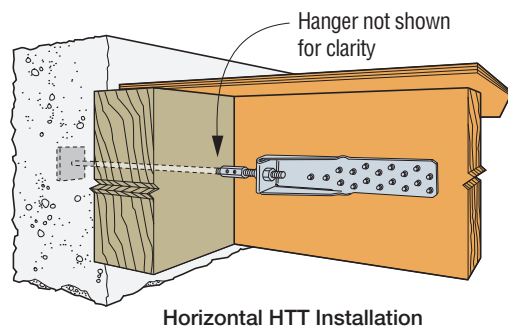
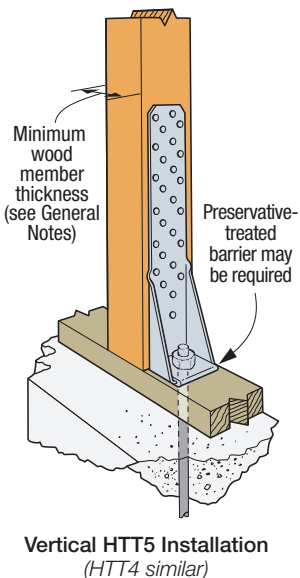
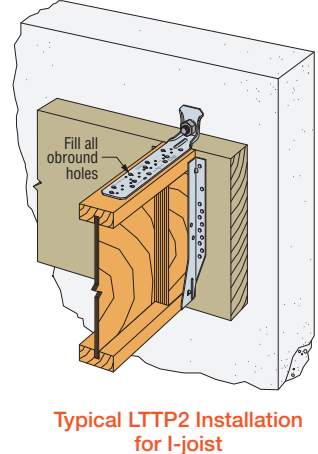
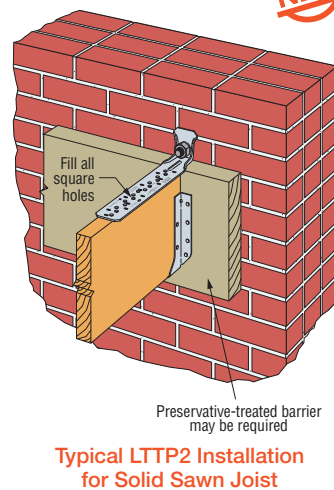
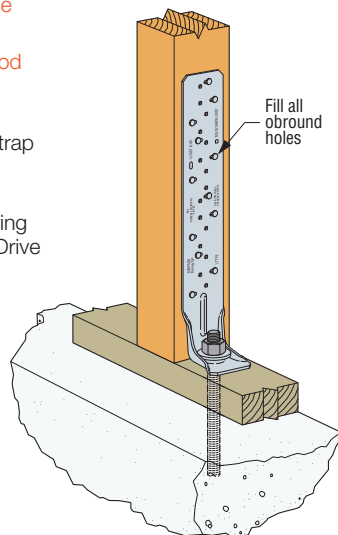
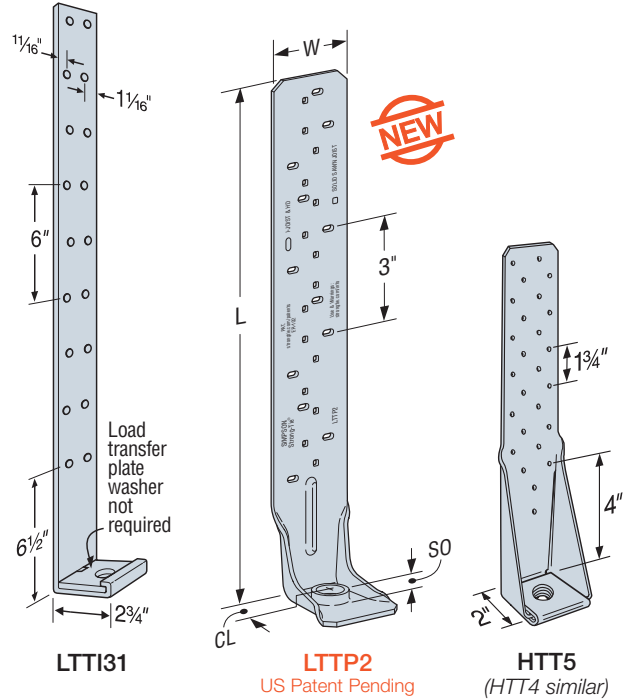

LTT/HTT

Tension Ties (cont.)

These products are available with additional corrosion protection. For more information, see p. 14.

SD Many of these products are approved for installation with Strong-Drive® SD Connector screws. See pp. 348–352 for more information.

Model No.	Ga.	Dimensions (in.)			SO (in.)	Fasteners (in.)		Minimum Wood Member Size (in.)	Allowable Tension Loads (160)		Deflection at Highest Allowable Load (in.)	Code Ref.
		W	L	CL		Anchor Rod Diameter	Wood Fasteners		DF/SP	SPF/HF		
LTPP2	10	2 3/16	14 15/16	1 1/8	7/16	1/2, 5/8, 3/4	(15) 0.148 x 2 1/2	1 1/2 x 3 1/2 (narrow edge) ^{4,5}	1,845	1,695	0.104	IBC, FL, LA
						1/2	(12) 0.148 x 1 1/2	1 1/2 x 3 1/2	1,680 ⁶	1,545 ⁶	0.138	
						5/8, 3/4	(12) #9 x 1 1/2" SD	1 1/2 x 3 1/2	2,135	1,965	0.112	
						1/2			2,320	1,970	0.112	
						5/8, 3/4			2,570	2,045	0.136	
1/2, 5/8, 3/4	(12) 0.148 x 2 1/2	3 x 3 1/2	2,275	2,230	0.128							
LTTI31	18	3 3/4	31	1 3/8	1/4	5/8	(18) 0.148 x 1 1/2	3 x 3 1/2	1,350	1,160	0.193	
HTT4	11	2 1/2	12 3/8	1 5/16	7/16	5/8	(18) 0.148 x 1 1/2	1 1/2 x 3 1/2	3,000	2,580	0.090	—
							(18) 0.148 x 1 1/2	3 x 3 1/2	3,610	3,105	0.086	IBC, FL, LA
							(18) 0.162 x 2 1/2	3 x 3 1/2	4,235	3,640	0.123	—
							(18) #10 x 1 1/2" SD	1 1/2 x 5 1/2	4,455	3,830	0.112	—
							(18) #10 x 1 1/2" SD	3 x 3 1/2	4,455	3,830	0.112	—
HTT5	11	2 1/2	16	1 7/16	7/16	5/8	(26) 0.148 x 1 1/2	3 x 3 1/2	4,350	3,740	0.120	IBC, FL, LA
							(26) 0.148 x 3	3 x 3 1/2	4,670	4,015	0.116	
							(26) 0.162 x 2 1/2	3 x 3 1/2	5,090	4,375	0.135	
							(26) #10 x 1 1/2" SD	1 1/2 x 5 1/2	4,555	3,915	0.114	
HTT5KT	11	2 1/2	16	1 7/16	7/16	5/8	(26) #10 x 2 1/2" SD	3 x 3 1/2	5,445	5,360	0.103	—
HTT5-3/4	11	2 1/2	16	1 7/16	7/16	3/4	(26) 0.148 x 1 1/2	1 1/2 x 5 1/2	4,065	3,495	0.103	IBC, FL
							(26) 0.162 x 2 1/2	3 x 3 1/2	5,090	4,375	0.121	
							(26) #10 x 1 1/2" SD	1 1/2 x 7 1/4	4,830	4,155	0.100	

- LTTI31 installed flush with concrete or masonry has an allowable load of 2,285 lb.
- Allowable load for HTT5 with a BP5/8-2 bearing-plate washer installed in the seat of the holdown is 5,295 lb. for DF/SP and 4,555 lb. for SPF/HF.
- For LTPP2, standard cut washer is required when using 1/2" and 5/8" anchor rods.
- For (15) nail installations on narrow edge of 2x4 (minimum) joist, LTPP2 installed flush with concrete or masonry has an allowable load of 2,560 lb. for DF/SP and 2,355 lb. for SPF/HF.
- LTPP2 installed with (15) #9 x 1 1/2" SD screws on narrow edge of 2x joist has an allowable load of 2,105 lb. for DF/SP and 1,935 lb. for SPF/HF.
- For (12) nail installations on I-joist or wide face of 2x member, LTPP2 installed flush with concrete or masonry has an allowable load of 1,950 lb. for DF/SP and 1,795 lb. for SPF/HF.
- Fasteners:** Nail dimensions are listed diameter by length. SD screws are Simpson Strong-Tie® Strong-Drive SD Connector screws. See pp. 21–22 for fastener information.

Table 1 — Anchorage Selection Guide for Holdowns Attached to DF/SP Lumber

Holdown on DF/SP Lumber	Stemwall Width (in.)	Stemwall				Slab on Grade			
		Wind and Seismic Design Category A&B		Seismic Design Category C-F		Wind and Seismic Design Category A&B		Seismic Design Category C-F	
		Midwall/Corner	End Wall	Midwall/Corner	End Wall	Midwall/Corner	Garage Curb	Midwall/Corner	Garage Curb
HDU2	6	SSTB16		SSTB24		SSTB16		SSTB16	
HDU4	6	SB5/8X24		SB5/8X24		SSTB16	SB5/8X24	SSTB20	SB5/8X24
HDU5	6	SB5/8X24		SB5/8X24		SSTB20	SB5/8X24	SSTB24	SB5/8X24

Table 2 — Anchorage Selection Guide for Holdowns Attached to SPF/HF Lumber

Holdown on SPF/HF Lumber	Stemwall Width (in.)	Stemwall				Slab on Grade			
		Wind and Seismic Design Category A&B		Seismic Design Category C-F		Wind and Seismic Design Category A&B		Seismic Design Category C-F	
		Midwall/Corner	End Wall	Midwall/Corner	End Wall	Midwall/Corner	Garage Curb	Midwall/Corner	Garage Curb
LTPP2	6	SSTB16		SSTB16		SSTB16		SSTB16	
LTTI31	6	SSTB16		SSTB24		SSTB16		SSTB16	
HTI4	6	SSTB24* (4.295)		SB5/8X24		SSTB16	SSTB24* (4.295)	SSTB20	SB5/8X24
HTI5	8	SSTB28		SSTB28		SSTB28* (6.395)		SSTB28	
HD38	8	SSTB28		SSTB28		SSTB28* (6.395)		SSTB28	
HD58	8	SSTB28		SSTB28		SSTB28* (6.395)		SSTB28	
HDU11	8	SB1X30* (9.505)	PAB8	PAB8	PAB8	SB1x30		SB1x30	
HHQ11	8	SB1X30	PAB8	PAB8	PAB8	SB1x30		SB1x30	
HDU14	—	PAB8		PAB8		SB1x30		SB1x30	
HDU12	—	PAB8		PAB8		SB1x30		SB1x30	
LTPP2	6	SSTB16		SSTB16		SSTB16		SSTB16	
LTTI31	6	SSTB16		SSTB24		SSTB16		SSTB16	
HTI4	6	SSTB20		SB5/8X24		SSTB16	SSTB20	SSTB16* (3.780)	SB5/8X24
HTI5	6	SB5/8X24		SB5/8X24		SSTB20	SB5/8X24	SSTB24	SB5/8X24

We've made selecting the right anchor bolt for the holdown easier. Check out our Holdown Anchorage Solutions table on p. 44 or the Post-to-Foundation Designer at app.strongtie.com/pfd.