

SCHA Slide-Clip Connectors for Horizontal Anchorage



This product is preferable to similar connectors because of a) easier installation, b) higher loads, c) lower installed cost, or a combination of these features.

SCHA connectors are an ideal solution for panelized or stick-frame construction where the CFS framing anchors to the top of a concrete floor slab or the bottom of a steel beam. The connector features a wide support leg to decrease eccentricity on anchors and provide a variety of anchorage options. The included SCVC vertical slider helps to strengthen the connector for the highest tension (F₂) and compression (F₃) loads in the industry.

Features:

- Provides a full 1" of both upward and downward movement
- Tabulated design values for anchorage help mitigate risk and provide ease of specification
- Either face of anchorage leg can be used against the support
- Accommodates stand-off distances up to 4¾"
- Can be used with 3¾", 4", 6" and 8" studs
- Prepunched anchor holes accommodate ¼"-diameter Titen HD® or other ¼"-diameter concrete screw anchors, and 0.157"-diameter powder-actuated fasteners such as the Simpson Strong-Tie® PDPAT-62KP
- Prepunched anchor holes also eliminate the need for pre-drilling and help ensure accurate anchor placement

Material: SCHA — 118 mil (10 ga., 33 ksi);
SCVS — 97 mil (12 ga., 33 ksi)

Coating: Galvanized (G90)

Installation:

- Use all specified fasteners and anchors. Note that the smaller diameter anchor holes are provided for PAF installation, and the larger diameter anchor holes are for ¼"-diameter concrete screw anchors.
- Ensure that the SCVS vertical slider is centered in the SCHA vertical slots by aligning the tic-marks adjacent to the triangle holes on the slider with the ≠ stamp on the SCHA clip.

Codes: See p. 11 for Code Reference Key Chart

Ordering Information:

- SCHA10.75-KT15 contains (15) SCHA10.75 connectors and (15) SCVS/97 sliders
- SCHA10.75L-KT15 contains (15) SCHA10.75L connectors and (15) SCVS/97 sliders

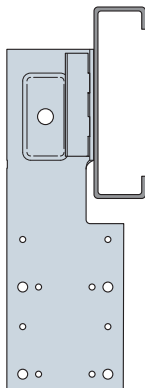

SCHA10.75
(plan view with vertical leg up)

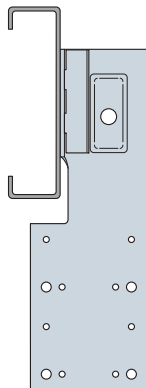

SCHA10.75L
(plan view with vertical leg up)

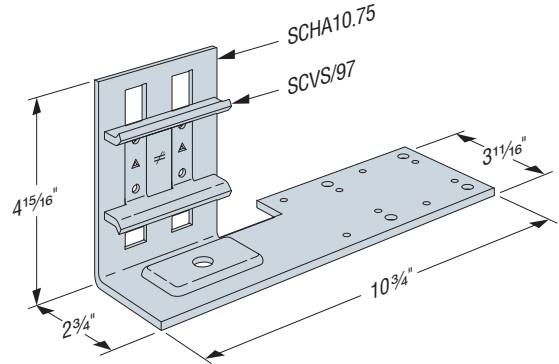

SCHA10.75 with SCVS/97
US Patent Pending

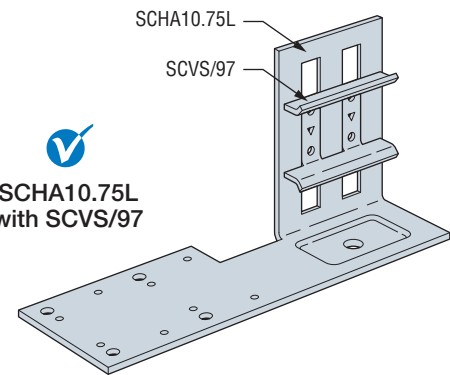

SCHA10.75L with SCVS/97

SCHA Anchorage Types and Conditions

Four PDPAT Anchors to Steel	
Front Condition	End Condition
4" Weld	
Front Condition	End Condition
¼"-Diameter Concrete Screws	
Four Anchors	Two Anchors

SCHA Slide-Clip Connectors for Horizontal Anchorage



SCHA Allowable Loads

Primary Structure Base Material	Anchorage		Fasteners to Stud Self-Drilling Screws		Stud Thickness mil (ga.)	Maximum Stand-Off Distance (in.)	Allowable Load (lb.)			Code Ref.	
	Qty./Type/Size	Condition	Min./Max.	No. #12-14			F ₁ '	F ₂	F ₃		
Structural steel A36 3/16" thick minimum	(4) 0.157" x 5/8" powder-actuated fasteners PDPAT-62KP or (2) welds – 2" length	Front condition	Min.	4	33 (20)	2	150	645	490	—	
					43 (18)		195	860	610		
					54 (16)		235	990	880		
			68 (14)	235	990	880					
			Max.	6	54 (16)	2	350	1,300	1,045		
					68 (14)		350	1,495	1,045		
		End condition	Min.	4	4 3/4	33 (20)	4 3/4	105	625		470
						43 (18)		110	830		570
						54 (16)		165	830		720
			68 (14)	165	830	720					
			Max.	6	4 3/4	54 (16)	4 3/4	350	1,060		775
						68 (14)		350	1,060		775
Normal or lightweight concrete f _c = 2,500 psi minimum	(4) concrete screw anchors – 1/4" diameter ³	4 anchors	Min.	4	33 (20)	2	105	625	470		
					43 (18)		110	830	570		
					54 (16)		165	830	720		
		68 (14)	165	830	720						
		Max.	6	2	54 (16)	2	350	1,060	775		
					68 (14)		350	1,060	775		
	(2) concrete screw anchors – 1/4" diameter ³	2 anchors	Min.	4	4 3/4	33 (20)	4 3/4	105	625	470	
						43 (18)		105	830	570	
						54 (16)		165	830	720	
		68 (14)	165	830	720						
		Max.	6	4 3/4	54 (16)	4 3/4	350	860	745		
					68 (14)		350	860	745		

- For additional important information, see General Information and Notes on p. 22.
- Allowable loads are based on connectors installed with tabulated anchorage type, quantity and size into structural steel. For anchorage installations into concrete, the capacity of the connection system will be the minimum of the tabulated value and the allowable load using concrete screws indicated on the table on p. 49. Note that if the designer chooses to calculate concrete anchorage with alternate 1/4"-diameter anchors, then the maximum load shall not exceed the tabulated values in this table. Refer to the figures on p. 47 for anchorage conditions.
- Please refer to the table on p. 49 for Simpson Strong-Tie® Titen HD anchorage loads.
- Min. fasteners quantity and tabulated values — fill round holes; max. fasteners quantity and tabulated values — fill round and triangular holes.
- The stand-off is the distance from the interior flange of the stud to the face of the supporting structure. Note that the interior flange of the stud is assumed to align with the inside vertical edge of the connector as indicated in the illustrations on p. 49.
- Tabulated values are based on 3/8" studs. Web crippling checks for deeper members are the responsibility of the designer.
- Tabulated F₁ loads are based on assembly tests with the load through the centerline of stud. Tested failure modes were due to screw pullout; therefore compare F₁ against F_p calculated per ASCE 7-10 Chapter 13 with a_p = 1.25 and R_p = 1.0.

SCHA Slide-Clip Connectors for Horizontal Anchorage

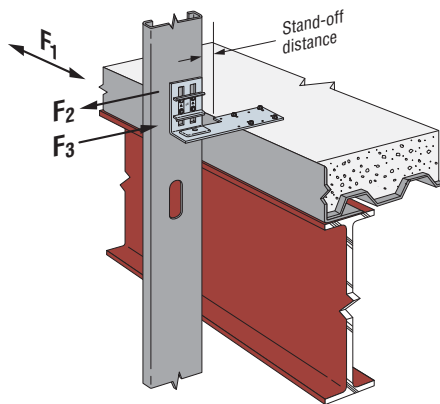

Typical SCHA Installation
at Floor Slab

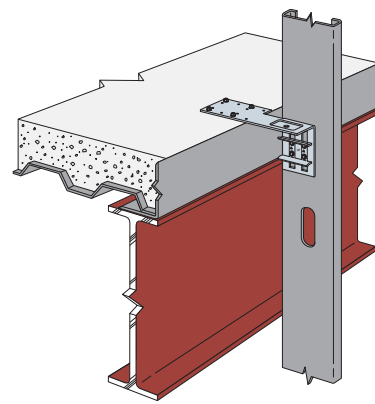

Typical SCHA Installation
at Floor Slab
(inverted)

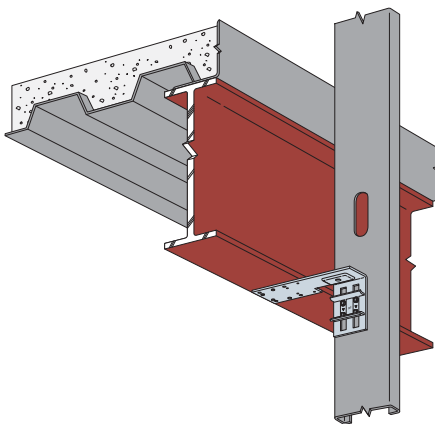

Typical SCHA Installation
at Beam Flange

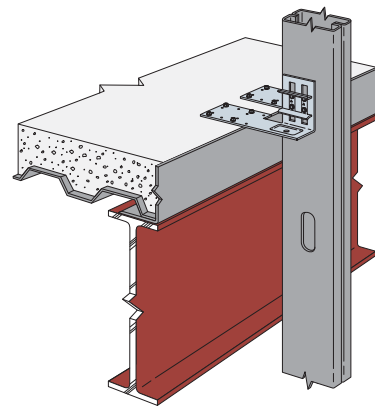

Typical SCHA Installation
for Built-Up Studs at Floor Slab
(SCHA10.75L near side and
SCHA10.75 far side)

Allowable Titen HD® Anchorage Loads into Concrete with SCHA Clip

Anchorage Type	Nominal Embedment (in.)	Anchors Quantity and Size	f'_c (psi)	Allowable Anchor Load (lb.) F_2 and F_3			
				Wind and Seismic in SDC A & B		Seismic in SDC C through F	
				Uncracked Concrete	Cracked Concrete	Cracked Concrete ($\Omega = 1.0$)	Cracked Concrete ⁷ ($\Omega = 2.5$)
Simpson Strong-Tie® Titen HD screw anchor THDB25178H	1½"	(4) ¼" x 17/8"	2,500	1,025	730	855	350
	1½"	(2) ¼" x 17/8"	2,500	510	365	425	175

1. Allowable anchor capacities have been determined using ACI 318-14 Chapter 17 calculations with a minimum concrete compressive strength (f'_c) of 2,500 psi and 5" slab thickness in normal-weight concrete. Tabulated values can be multiplied by a factor (λ_a) of 0.6 for sand-lightweight concrete.
2. Nominal Embedment Depth/Effective Embedment Depth relationship is $1.75" (h_{nom}) / 1.30" (h_{ef})$.
3. Edge distance is assumed to be 2", and end distance is 7½".
4. Load values are for group anchors based on ACI 318-14, condition B, load factors from ACI 318-14 Section 5.3, no supplement edge reinforcement, $\Psi_{c,v} = 1.0$ for cracked concrete and periodic special inspection.
5. Allowable Stress Design (ASD) values were determined by multiplying calculated LRFD capacities by a conversion factor, Alpha (α), of 0.70 for seismic load and 0.6 for wind loads. ASD values for other combinations may be determined using alternate conversion factors.
6. Tabulated allowable ASD loads for Wind and Seismic in SDC A&B are based on using wind conversion factors and may be increased by 1.17 for SDC A&B only.
7. Allowable loads have been divided by an Omega (Ω) seismic factor of 2.5 for brittle failure as required by ACI 318-14 Chapter 17.
8. Allowable F_2 and F_3 loads are based on the governing loading direction, which is toward the edge of slab.
9. Tabulated capacities are based on maximum allowable anchorage loads only. The capacity of the connection system shall be the minimum of the tabulated value and the SCHA Allowable Connector Loads.