

SUBH Bridging Connectors

Simplified Design and Installation Through Innovation

Simpson Strong-Tie® SUBH and MSUBH wall stud bridging connectors for cold-formed steel (CFS) framing offer a compact profile that allows standard 1½" studs to be sistered directly against adjacent studs. The LSUBH connector provides the same installation benefits of the SUBH/MSUBH connectors, and is suitable for many wind- and load-bearing situations where the load demand is light to moderate.

Many applications require only one screw, greatly reducing labor costs and increasing productivity.



This product is preferable to similar connectors because of a) easier installation, b) higher loads, c) lower installed cost, or a combination of these features.

Features:

- Tested to include stud-web strength and stiffness in the tabulated design values
- Design values ensure compliance with AISI S100 Sections D3.2.1 and D3.3 for axially and laterally loaded studs
- Flexible design solutions for web thicknesses of 33 mil (20 ga.) through 97 mil (12 ga.) and stud sizes from 3½" to 8"
- SUBH and LSUBH accommodates single studs 33 mil (20 ga.) to 54 mil (16 ga.)
- MSUBH accommodates single studs 54 mil (16 ga.) to 97 mil (12 ga.) and back-to-back built-up members ranging from 33 mil (20 ga.) to 54 mil (16 ga.)

Material: LSUBH3.25 — 33 mil (20 ga.); SUBH3.25 — 43 mil (18 ga.); MSUBH3.25 — 68 mil (14 ga.)

Finish: Galvanized (G90)

Installation:

- See pp. 120 through 122

Codes: See p. 11 for Code Reference Key Chart

Ordering Information:

LSUBH3.25 and SUBH3.25-R150 (Bucket of 150), MSUBH3.25-R100 (Bucket of 100)



Compact Geometry

Facilitates efficient installation in industry-standard 1.5" web knockouts

Web Slots

Offers strong rotational resistance without the use of screws

Embossments

Enhance connector strength and stiffness

Contoured Flanges

Fits snug over industry-standard 1.5" wide u-channels

Dual Installation Options

For maximum design and application flexibility

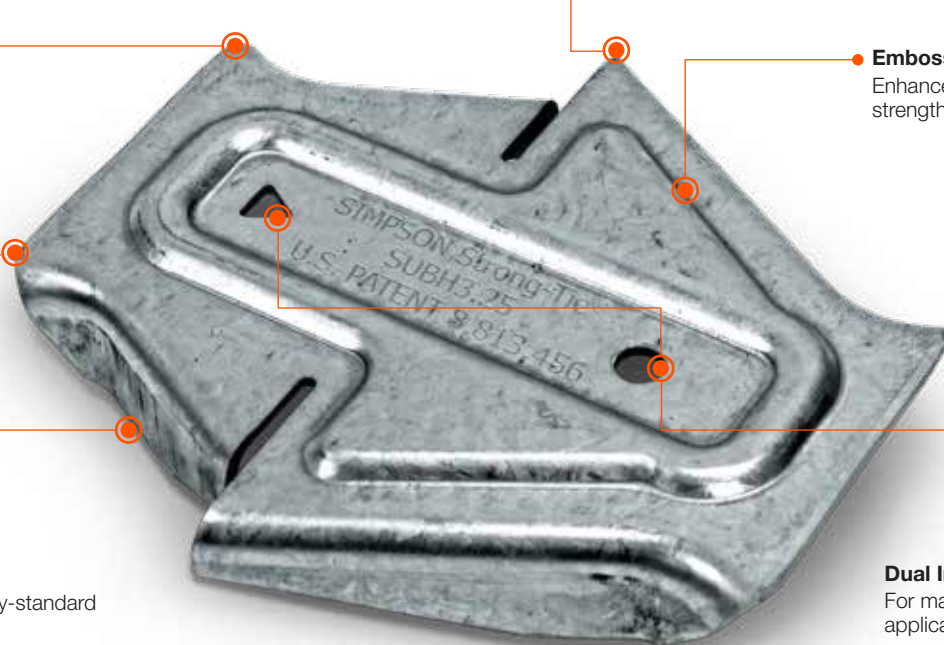

SUBH3.25
(LSUBH3.25 and MSUBH3.25 similar)
US Patent 8,813,456

SUBH Bridging Connectors

Installation Instructions

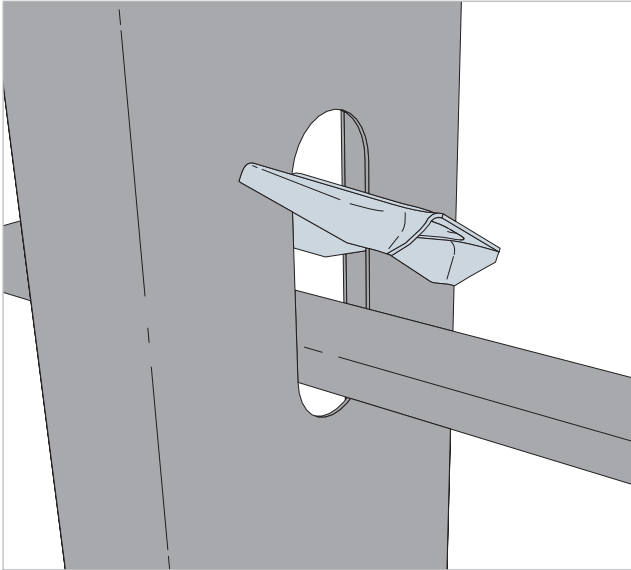

Step 1: With the u-channel in a stable, horizontal position, insert either end of the SUBH into the web knockout at approximately 45°.

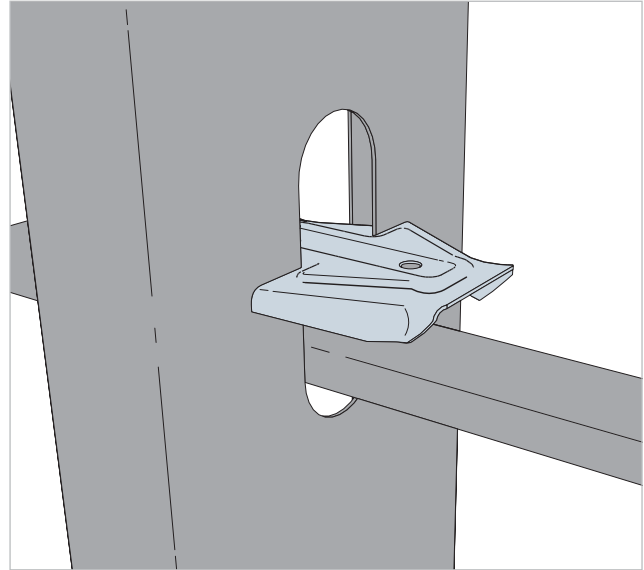

Step 2: Rotate the SUBH into a horizontal position aligned with the u-channel so the slots engage the stud web.

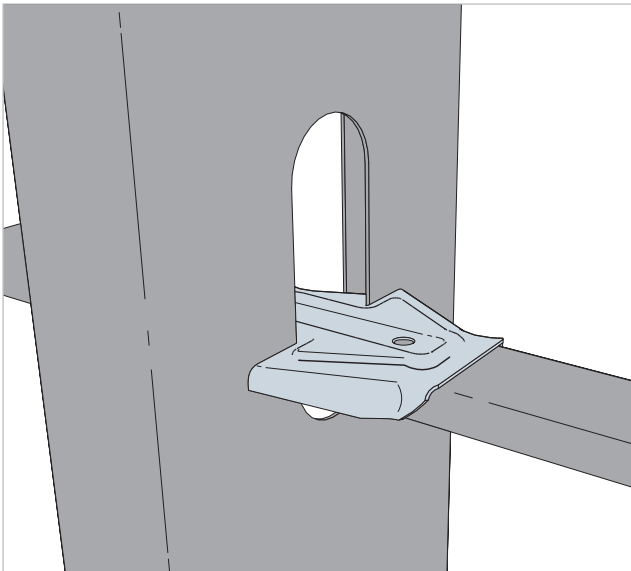

Step 3: Slide the SUBH down over the u-channel flanges, ensuring that the connector and u-channel are fully seated.
(Note: For installations at slip track, the connector may be installed inverted — see p. 121.)

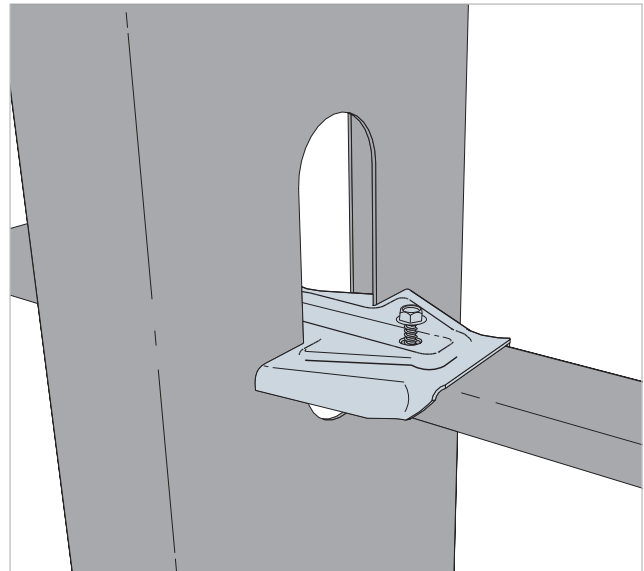

Step 4: Install the specified type and number of screws through the holes of the SUBH into the u-channel.

SUBH Bridging Connectors

Installation Details

Typical Orientations

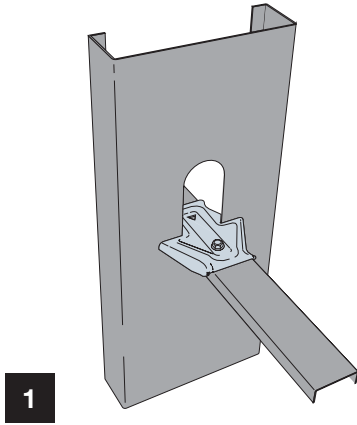

1 Round Hole Near Side

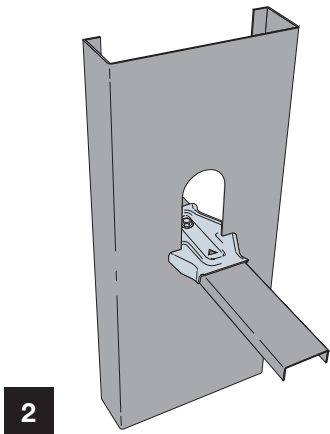

2 Round Hole Far Side

Recommended Details at Built-Up Studs

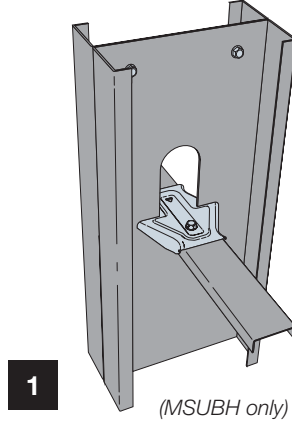

1 (MSUBH only)

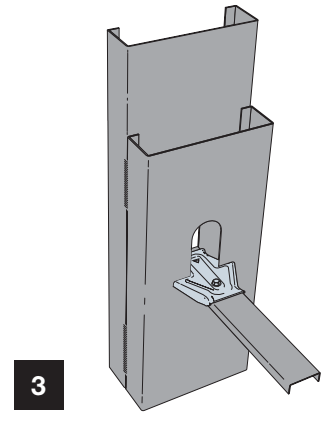

3

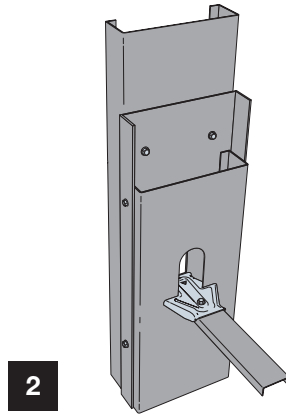

2

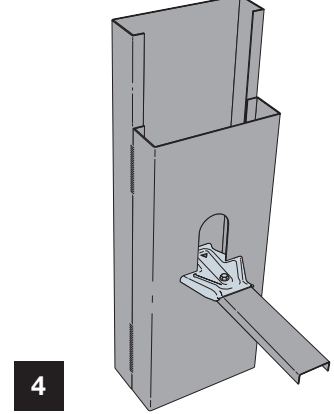

4

Recommended Detail at Slip Track

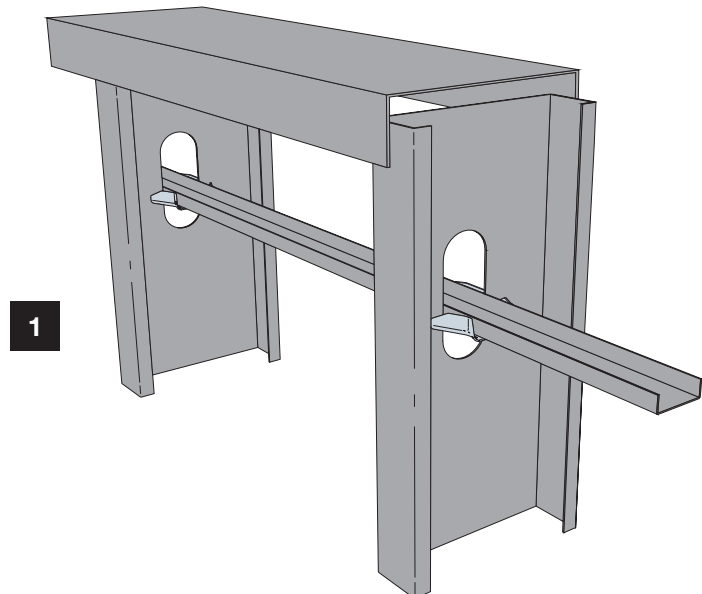

1

SUBH Bridging Connectors

Alternate and Optional U-Channel Bridging Installation Details

Recommended details where knockout access is restricted, or where additional u-channel restraint is needed for load path considerations.

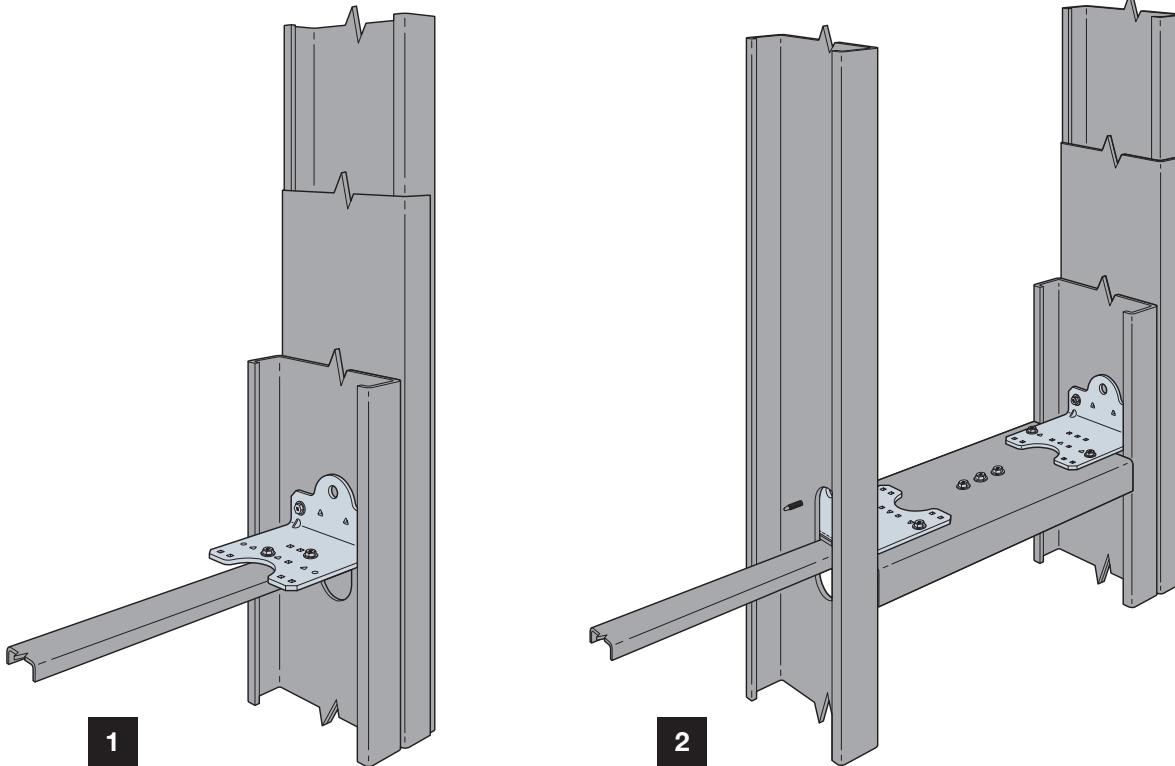

SUBH Bridging Connectors

How to Use Bridging Connector Allowable Load Table

The tabulated strength and stiffness values are for use with Sections D3.2.1 and D3.3 of the 2012 edition of AISI North American Specification for the Design of Cold-Formed Steel Structural Members (AISI S100-2012) as follows:

Bracing Design for Laterally Loaded C-Studs

- Step 1: Calculate required bracing force for each flange using equation D3.2.1-3
- Step 2: Multiply result by stud depth to obtain torsional moment
- Step 3: Select connector with tabulated allowable torsional moment that exceeds torsional moment from Step 2 for the stud depth and gauge required

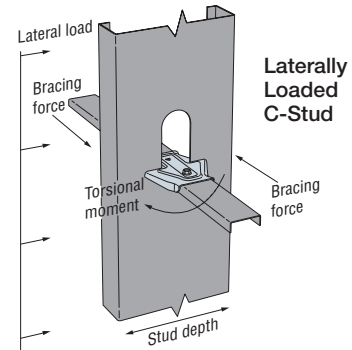

Bracing Design for Axially Loaded C-Studs

- Step 1: Calculate required brace strength using equation D3.3-1
- Step 2: Calculate required brace stiffness using equation D3.3-2a
- Step 3: Select connector with tabulated allowable brace strength that exceeds strength from Step 1 and tabulated brace stiffness that exceeds stiffness from Step 2 for the stud depth and gauge required

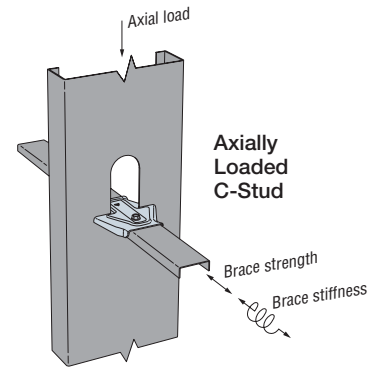

Bridging and Bracing Connectors

SUBH Bridge Clip Connector – Strength and Stiffness

Model No.	Stud Depth (in.)	Stud Thickness mils (ga.)	Laterally Loaded C-Stud		Axially Loaded C-Stud			Code Ref.	
			Allowable Torsional Moment ¹ (in.-lb.)		Allowable Brace Strength ^{1,2} (lb.)		Brace Stiffness ³ (lb./in.)		
			Min.	Max.	Min.	Max.	Min.		Max.
LSUBH3.25	3.625	33 (20)	215	330	155	275	2,300	2,685	IBC, FL, LA
		43 (18)	230	370	175	310	5,075	7,585	
		54 (16)	225	370	195	345	5,075	8,100	
SUBH3.25		33 (20)	320	345	230	370	1,450	1,985	
		43 (18)	355	430	255	420	2,780	4,035	
		54 (16)	420	455	290	475	2,925	3,975	
MSUBH3.25		54 (16)	550	800	435	630	3,440	4,015	
		68 (14)	640	860	485	695	4,040	6,145	
		97 (12)	670	860	515	770	6,860	14,265	
LSUBH3.25	6.00	33 (20)	225	330	120	140	670	730	
		43 (18)	250	395	155	285	1,010	2,075	
		54 (16)	265	395	180	330	1,025	2,565	
SUBH3.25		33 (20)	275	385	110	110	605	605	
		43 (18)	295	525	230	250	1,050	1,205	
		54 (16)	350	550	275	415	1,130	1,700	
MSUBH3.25		54 (16)	565	895	385	430	1,630	1,695	
		68 (14)	655	925	455	620	1,860	2,655	
		97 (12)	690	960	505	765	4,070	4,090	
LSUBH3.25	8.00	43 (18)	235	375	135	135	815	815	
		54 (16)	250	375	180	260	1,130	1,130	
		SUBH3.25	43 (18)	255	570	190	190	505	535
54 (16)			325	605	250	300	895	1,025	
54 (16)			545	890	270	270	1,025	1,045	
MSUBH3.25		68 (14)	635	925	435	455	1,400	1,400	
		97 (12)	665	955	545	545	2,465	2,465	
		MSUBH	10, 12	54 (16)	—	820	—	200	—

1. Allowable loads are for use when utilizing Allowable Stress Design methodology. For LRFD loads multiply the ASD tabulated values by 1.6.
2. Allowable brace strengths are based on ultimate test load divided by a safety factor. Serviceability limit is not considered, as brace stiffness requirements are given in section D3.3 of AISI S100-2012. Contact Simpson Strong-Tie if nominal brace strength is required.
3. Tabulated stiffness values apply to both ASD and LRFD designs.
4. Allowable loads consider bridging connection only. It is responsibility of the designer to verify the strength and serviceability of the framing members.
5. Min. fastener quantity and tabulated values – fill round and triangle holes (two screws total); Max. fastener quantity and tabulated values – fill round and triangle holes (two screws total).

SUBH Design Tables

LSUBH — Maximum Vertical Spacing for Rows of U-Channel Bridging (ft.)

Stud Spacing (in.)	Stud Section	Stud Thickness mil (ga.)	Lateral Stud Pressure (psf)																					
			5		10		15		20		25		30		35		40		45		50			
			Min.	Max.	Min.	Max.	Min.	Max.	Min.	Max.	Min.	Max.	Min.	Max.	Min.	Max.	Min.	Max.	Min.	Max.	Min.	Max.		
16	362S162	33 (20)	8	8	8	8	8	8	8	6	8	5	8	4	6	—	5	—	5	—	4	—	4	
		43 (18)	8	8	8	8	8	8	7	8	5	8	4	7	4	6	—	5	—	5	—	5	—	4
		54 (16)	8	8	8	8	8	8	7	8	5	8	4	7	4	6	—	5	—	5	—	5	—	4
	362S200	33 (20)	8	8	8	8	6	8	5	8	4	6	—	5	—	4	—	4	—	—	—	—	—	—
		43 (18)	8	8	8	8	7	8	5	8	4	7	—	6	—	5	—	4	—	4	—	4	—	—
		54 (16)	8	8	8	8	7	8	5	8	4	7	—	6	—	5	—	4	—	4	—	4	—	—
	362S250	43 (18)	8	8	8	8	6	8	4	7	—	5	—	4	—	4	—	—	—	—	—	—	—	—
		54 (16)	8	8	8	8	5	8	4	7	—	5	—	4	—	4	—	—	—	—	—	—	—	—
	600S162	33 (20)	8	8	8	8	8	8	8	8	6	8	5	8	4	6	4	6	4	6	—	5	—	4
		43 (18)	8	8	8	8	8	8	8	8	7	8	6	8	5	8	4	7	4	7	4	6	—	5
		54 (16)	8	8	8	8	8	8	8	8	7	8	6	8	5	8	4	7	4	7	4	6	—	5
	600S200	33 (20)	8	8	8	8	8	8	6	8	4	7	4	6	—	5	—	4	—	4	—	4	—	—
		43 (18)	8	8	8	8	8	8	6	8	5	8	4	7	—	6	—	5	—	4	—	4	—	4
		54 (16)	8	8	8	8	8	8	7	8	5	8	4	7	4	6	—	5	—	4	—	4	—	4
	600S250	43 (18)	8	8	8	8	7	8	5	8	4	6	—	5	—	4	—	4	—	4	—	—	—	—
		54 (16)	8	8	8	8	7	8	5	8	4	6	—	5	—	4	—	4	—	4	—	—	—	—
	800S162	43 (18)	8	8	8	8	8	8	8	8	7	8	6	8	5	8	4	7	4	6	—	6	—	6
		54 (16)	8	8	8	8	8	8	8	8	8	7	8	6	8	5	8	4	7	4	7	4	6	—
800S200	43 (18)	8	8	8	8	8	7	8	5	8	4	7	4	6	—	5	—	5	—	5	—	4	—	4
	54 (16)	8	8	8	8	8	7	8	6	8	5	7	4	6	—	5	—	5	—	5	—	4	—	4
800S250	43 (18)	8	8	8	8	7	8	5	8	4	7	—	5	—	5	—	4	—	—	—	—	—	—	
	54 (16)	8	8	8	8	8	6	8	4	7	4	6	—	5	—	4	—	4	—	4	—	—	—	
24	362S162	33 (20)	8	8	8	8	6	8	4	6	—	5	—	4	—	—	—	—	—	—	—	—	—	
		43 (18)	8	8	8	8	6	8	4	7	—	6	—	5	—	4	—	—	—	—	—	—	—	
		54 (16)	8	8	8	8	6	8	4	7	—	6	—	5	—	4	—	—	—	—	—	—	—	
	362S200	33 (20)	8	8	6	8	4	7	—	5	—	4	—	—	—	—	—	—	—	—	—	—	—	
		43 (18)	8	8	7	8	4	8	—	6	—	4	—	4	—	—	—	—	—	—	—	—	—	
		54 (16)	8	8	7	8	4	8	—	6	—	4	—	4	—	—	—	—	—	—	—	—	—	
	362S250	43 (18)	8	8	6	8	4	6	—	4	—	—	—	—	—	—	—	—	—	—	—	—	—	
		54 (16)	8	8	5	8	—	6	—	4	—	—	—	—	—	—	—	—	—	—	—	—	—	
	600S162	33 (20)	8	8	8	8	7	8	5	8	4	6	—	5	—	4	—	4	—	—	—	—	—	
		43 (18)	8	8	8	8	8	8	6	8	4	7	4	6	—	5	—	4	—	4	—	—	—	
		54 (16)	8	8	8	8	8	8	6	8	5	7	4	6	—	5	—	4	—	4	—	—	—	
	600S200	33 (20)	8	8	8	8	5	8	4	6	—	4	—	4	—	—	—	—	—	—	—	—	—	
		43 (18)	8	8	8	8	6	8	4	7	—	5	—	4	—	4	—	—	—	—	—	—	—	
		54 (16)	8	8	8	8	6	8	4	7	—	5	—	4	—	4	—	—	—	—	—	—	—	
	600S250	43 (18)	8	8	7	8	4	7	—	5	—	4	—	—	—	—	—	—	—	—	—	—	—	
		54 (16)	8	8	7	8	5	7	—	5	—	4	—	—	—	—	—	—	—	—	—	—	—	
	800S162	43 (18)	8	8	8	8	8	8	6	8	5	8	4	6	—	5	—	5	—	4	—	4	—	4
		54 (16)	8	8	8	8	8	8	7	8	5	8	4	7	4	6	—	5	—	4	—	4	—	4
800S200	43 (18)	8	8	8	8	6	8	4	7	—	6	—	5	—	4	—	—	—	—	—	—	—	—	
	54 (16)	8	8	8	8	6	8	5	7	4	6	—	5	—	4	—	—	—	—	—	—	—	—	
800S250	43 (18)	8	8	7	8	5	7	—	5	—	4	—	—	—	—	—	—	—	—	—	—	—	—	
	54 (16)	8	8	8	8	5	8	4	6	—	4	—	4	—	—	—	—	—	—	—	—	—	—	

1. See General Information and Notes on pp. 14–15 and 22.
2. Tabulated solutions are for ASD lateral pressure. Contact Simpson Strong-Tie for LRFD solutions.
3. Lateral pressure shall be determined based on load combinations of the applicable code. For designs in accordance with the 2009 IBC and earlier, wind pressures are at working stress level and may be used directly. For designs in accordance with the 2012 IBC and later, wind pressures are at strength level and must be multiplied by 0.6 for ASD load combinations.
4. "Min." designates a solution with the minimum number of fasteners ((1) #10 screw installed in round hole). "Max." designates a solution requiring the maximum number of fasteners ((2) #10 screws; fill both round and triangle holes). Blank areas designate conditions where the LSUBH does not offer a solution.

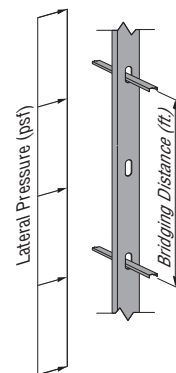

SUBH Design Tables

SUBH — Maximum Vertical Spacing for Rows of U-Channel Bridging (ft.)

Stud Spacing (in.)	Stud Section	Stud Thickness mil (ga.)	Lateral Stud Pressure (psf)																							
			5		10		15		20		25		30		35		40		45		50					
			Min.	Max.	Min.	Max.	Min.	Max.	Min.	Max.	Min.	Max.	Min.	Max.	Min.	Max.	Min.	Max.	Min.	Max.	Min.	Max.				
16	362S162	33 (20)	8	8	8	8	8	8	8	8	8	8	8	8	8	8	8	8	8	8	8	8	8			
		43 (18)	8	8	8	8	8	8	8	8	8	8	8	8	8	8	8	8	8	8	8	8	8	8		
		54 (16)	8	8	8	8	8	8	8	8	8	8	8	8	8	8	8	8	8	8	8	8	8	8	8	
	362S200	33 (20)	8	8	8	8	8	8	8	7	8	6	6	5	5	4	4	—	4	—	—	—	—	—	—	
		43 (18)	8	8	8	8	8	8	8	8	8	6	8	5	6	4	5	4	5	—	4	—	4	—	4	
		54 (16)	8	8	8	8	8	8	8	8	8	8	8	6	7	5	6	5	5	4	4	4	4	4	4	
	362S250	43 (18)	8	8	8	8	8	8	8	6	8	5	6	4	5	—	4	—	4	—	—	—	—	—	—	
		54 (16)	8	8	8	8	8	8	8	8	6	7	5	5	4	5	4	4	—	—	—	—	—	—	—	
	600S162	33 (20)	8	8	8	8	8	8	8	8	8	8	8	6	8	5	8	5	7	4	6	4	5	5	5	
		43 (18)	8	8	8	8	8	8	8	8	8	8	8	7	8	6	8	5	8	4	8	4	7	7	7	
		54 (16)	8	8	8	8	8	8	8	8	8	8	8	8	7	8	6	8	5	8	5	8	5	8	8	
	600S200	33 (20)	8	8	8	8	8	8	7	8	6	8	5	7	4	6	—	5	—	4	—	4	—	4	—	
		43 (18)	8	8	8	8	8	8	8	8	6	8	5	8	4	8	4	7	—	6	—	6	—	5	5	
		54 (16)	8	8	8	8	8	8	8	8	7	8	6	8	5	8	4	7	4	6	—	6	—	6	—	
	600S250	43 (18)	8	8	8	8	8	8	6	8	5	8	4	7	—	6	—	5	—	5	—	5	—	4	—	
		54 (16)	8	8	8	8	8	8	7	8	6	8	5	8	4	6	—	6	—	6	—	5	—	4	—	
	800S162	43 (18)	8	8	8	8	8	8	8	8	8	8	7	8	6	8	5	8	4	8	4	8	4	8	8	
		54 (16)	8	8	8	8	8	8	8	8	8	8	8	8	7	8	6	8	6	8	6	8	5	8	8	
	800S200	43 (18)	8	8	8	8	8	8	7	8	6	8	5	8	4	8	—	8	—	7	—	7	—	7	—	
		54 (16)	8	8	8	8	8	8	8	8	8	8	6	8	5	8	5	8	4	8	4	8	4	7	—	
	800S250	43 (18)	8	8	8	8	8	6	8	4	8	4	8	—	7	—	6	—	6	—	6	—	5	—	5	
		54 (16)	8	8	8	8	8	7	8	6	8	5	8	4	8	4	8	—	7	—	7	—	6	—	6	
	24	362S162	33 (20)	8	8	8	8	8	8	6	7	5	5	4	4	—	4	—	—	—	—	—	—	—	—	—
			43 (18)	8	8	8	8	8	8	7	8	6	7	5	6	4	5	—	4	—	4	—	4	—	—	—
54 (16)			8	8	8	8	8	8	8	8	7	7	6	6	5	5	4	4	4	4	4	4	—	—	—	
362S200		33 (20)	8	8	8	8	6	7	5	5	4	4	—	—	—	—	—	—	—	—	—	—	—	—	—	
		43 (18)	8	8	8	8	7	8	5	6	4	5	—	4	—	—	—	—	—	—	—	—	—	—	—	
		54 (16)	8	8	8	8	8	8	6	7	5	5	4	4	—	4	—	—	—	—	—	—	—	—	—	
362S250		43 (18)	8	8	8	8	6	7	4	5	—	4	—	—	—	—	—	—	—	—	—	—	—	—	—	
		54 (16)	8	8	8	8	7	7	5	5	4	4	—	—	—	—	—	—	—	—	—	—	—	—	—	
600S162		33 (20)	8	8	8	8	8	8	6	8	5	7	4	6	—	5	—	4	—	4	—	4	—	—	—	
		43 (18)	8	8	8	8	8	8	7	8	5	8	4	8	4	7	—	6	—	5	—	5	—	5	5	
		54 (16)	8	8	8	8	8	8	8	8	7	8	5	8	5	7	4	6	—	6	—	6	—	5	5	
600S200		33 (20)	8	8	8	8	6	8	5	7	4	5	—	4	—	4	—	—	—	—	—	—	—	—	—	
		43 (18)	8	8	8	8	7	8	5	8	4	7	—	6	—	5	—	4	—	4	—	4	—	—	—	
		54 (16)	8	8	8	8	8	8	6	8	5	8	4	6	—	5	—	5	—	4	—	4	—	4	—	
600S250		43 (18)	8	8	8	8	5	8	4	7	—	6	—	5	—	4	—	—	—	—	—	—	—	—	—	
		54 (16)	8	8	8	8	6	8	5	8	4	6	—	5	—	4	—	4	—	4	—	—	—	—	—	
800S162		43 (18)	8	8	8	8	8	8	7	8	5	8	4	8	4	8	—	7	—	7	—	7	—	6	—	
		54 (16)	8	8	8	8	8	8	8	8	7	8	6	8	5	8	4	8	4	8	4	7	—	6	—	
800S200		43 (18)	8	8	8	8	6	8	5	8	4	8	—	7	—	6	—	5	—	5	—	5	—	4	—	
		54 (16)	8	8	8	8	8	8	6	8	5	8	4	8	—	7	—	6	—	5	—	5	—	5	—	
800S250		43 (18)	8	8	8	8	5	8	4	8	—	7	—	6	—	5	—	4	—	4	—	4	—	—	—	
		54 (16)	8	8	8	8	6	8	5	8	4	7	—	6	—	5	—	4	—	4	—	4	—	—	—	

1. See General Information and Notes on pp. 14–15 and 22.
2. Tabulated solutions are for ASD lateral pressure. Contact Simpson Strong-Tie for LRFD solutions.
3. Lateral pressure shall be determined based on load combinations of the applicable code. For designs in accordance with the 2009 IBC and earlier, wind pressures are at working stress level and may be used directly. For designs in accordance with the 2012 IBC and later, wind pressures are at strength level and must be multiplied by 0.6 for ASD load combinations.
4. "Min." designates a solution with the minimum number of fasteners ((1) #10 screw installed in round hole). "Max." designates a solution requiring the maximum number of fasteners ((2) #10 screws; fill both round and triangle holes). Blank areas designate conditions where the SUBH does not offer a solution.

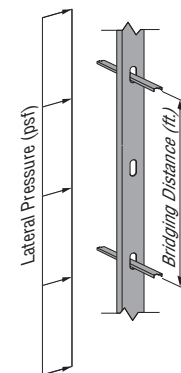

SUBH Design Tables

MSUBH — Maximum Vertical Spacing for Rows of U-Channel Bridging (ft.)

Stud Spacing (in.)	Stud Section	Stud Thickness mil (ga.)	Lateral Stud Pressure (psf)																					
			5		10		15		20		25		30		35		40		45		50			
			Min.	Max.	Min.	Max.	Min.	Max.	Min.	Max.	Min.	Max.	Min.	Max.	Min.	Max.	Min.	Max.	Min.	Max.	Min.	Max.		
16	362S162	54 (16)	8	8	8	8	8	8	8	8	8	8	8	8	8	8	8	8	8	7	8	7	8	
		68 (14)	8	8	8	8	8	8	8	8	8	8	8	8	8	8	8	8	8	8	8	8	8	8
		97 (12)	8	8	8	8	8	8	8	8	8	8	8	8	8	8	8	8	8	8	8	8	8	8
	362S200	54 (16)	8	8	8	8	8	8	8	8	8	8	8	8	8	7	8	6	8	6	8	5	7	
		68 (14)	8	8	8	8	8	8	8	8	8	8	8	8	8	8	7	8	7	8	8	6	8	
		97 (12)	8	8	8	8	8	8	8	8	8	8	8	8	8	8	8	8	7	8	7	8	6	8
	362S250	54 (16)	8	8	8	8	8	8	8	8	8	8	8	7	8	6	8	5	7	4	7	4	6	
		68 (14)	8	8	8	8	8	8	8	8	8	8	8	8	7	8	6	8	5	7	5	6		
		97 (12)	8	8	8	8	8	8	8	8	8	8	8	8	7	8	6	8	6	7	5	6		
	600S162	54 (16)	8	8	8	8	8	8	8	8	8	8	8	8	8	8	8	8	8	8	8	8	8	
		68 (14)	8	8	8	8	8	8	8	8	8	8	8	8	8	8	8	8	8	8	8	8	8	
		97 (12)	8	8	8	8	8	8	8	8	8	8	8	8	8	8	8	8	8	8	8	8	8	
	600S200	54 (16)	8	8	8	8	8	8	8	8	8	8	8	8	8	7	8	7	8	7	8	6	8	
		68 (14)	8	8	8	8	8	8	8	8	8	8	8	8	8	8	8	8	8	8	8	7	8	
		97 (12)	8	8	8	8	8	8	8	8	8	8	8	8	8	8	8	8	8	8	8	8	8	
	600S250	54 (16)	8	8	8	8	8	8	8	8	8	8	8	8	8	7	8	6	8	5	8	5	7	
		68 (14)	8	8	8	8	8	8	8	8	8	8	8	8	8	7	8	6	8	6	8	5	8	
		97 (12)	8	8	8	8	8	8	8	8	8	8	8	8	8	7	8	6	8	6	8	6	8	
	800S162	54 (16)	8	8	8	8	8	8	8	8	8	8	8	8	8	8	8	8	8	8	8	8	8	
		68 (14)	8	8	8	8	8	8	8	8	8	8	8	8	8	8	8	8	8	8	8	8	8	
		97 (12)	8	8	8	8	8	8	8	8	8	8	8	8	8	8	8	8	8	8	8	8	8	
	800S200	54 (16)	8	8	8	8	8	8	8	8	8	8	8	8	8	8	8	8	8	7	8	6	8	
		68 (14)	8	8	8	8	8	8	8	8	8	8	8	8	8	8	8	8	8	8	8	7	8	
		97 (12)	8	8	8	8	8	8	8	8	8	8	8	8	8	8	8	8	8	8	8	8	8	
800S250	54 (16)	8	8	8	8	8	8	8	8	8	8	8	8	7	8	6	8	5	8	5	8			
	68 (14)	8	8	8	8	8	8	8	8	8	8	8	8	7	8	6	8	6	8	6	8			
	97 (12)	8	8	8	8	8	8	8	8	8	8	8	8	8	8	7	8	7	8	6	8			
1000S162	54 (16)	—	8	—	8	—	8	—	8	—	8	—	8	—	8	—	8	—	8	—	8			
	68 (14)	—	8	—	8	—	8	—	8	—	8	—	8	—	8	—	8	—	8	—	8			
	97 (12)	—	8	—	8	—	8	—	8	—	8	—	8	—	8	—	8	—	8	—	8			
1000S200	54 (16)	—	8	—	8	—	8	—	8	—	8	—	8	—	8	—	8	—	8	—	8			
	68 (14)	—	8	—	8	—	8	—	8	—	8	—	8	—	8	—	8	—	8	—	8			
	97 (12)	—	8	—	8	—	8	—	8	—	8	—	8	—	8	—	8	—	8	—	8			
1000S250	54 (16)	—	8	—	8	—	8	—	8	—	8	—	8	—	8	—	8	—	8	—	8			
	68 (14)	—	8	—	8	—	8	—	8	—	8	—	8	—	8	—	8	—	8	—	8			
	97 (12)	—	8	—	8	—	8	—	8	—	8	—	8	—	8	—	8	—	8	—	8			
1200S162	54 (16)	—	8	—	8	—	8	—	8	—	8	—	8	—	8	—	8	—	8	—	8			
	68 (14)	—	8	—	8	—	8	—	8	—	8	—	8	—	8	—	8	—	8	—	8			
	97 (12)	—	8	—	8	—	8	—	8	—	8	—	8	—	8	—	8	—	8	—	8			
1200S200	54 (16)	—	8	—	8	—	8	—	8	—	8	—	8	—	8	—	8	—	8	—	8			
	68 (14)	—	8	—	8	—	8	—	8	—	8	—	8	—	8	—	8	—	8	—	8			
	97 (12)	—	8	—	8	—	8	—	8	—	8	—	8	—	8	—	8	—	8	—	8			
1200S250	54 (16)	—	8	—	8	—	8	—	8	—	8	—	8	—	8	—	8	—	8	—	8			
	68 (14)	—	8	—	8	—	8	—	8	—	8	—	8	—	8	—	8	—	8	—	8			
	97 (12)	—	8	—	8	—	8	—	8	—	8	—	8	—	8	—	8	—	8	—	8			

1. See General Information and Notes on pp. 14–15 and 22.
2. Tabulated solutions are for ASD lateral pressure. Contact Simpson Strong-Tie for LRFD solutions.
3. Lateral pressure shall be determined based on load combinations of the applicable code. For designs in accordance with the 2009 IBC and earlier, wind pressures are at working stress level and may be used directly. For designs in accordance with the 2012 IBC and later, wind pressures are at strength level and must be multiplied by 0.6 for ASD load combinations.
4. "Min." designates a solution with the minimum number of fasteners ((1) #10 screw installed in round hole). "Max." designates a solution requiring the maximum number of fasteners ((2) #10 screws; fill both round and triangle holes). Blank areas designate conditions where the MSUBH does not offer a solution.

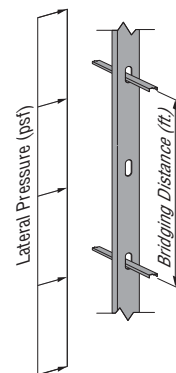

SUBH Design Tables

MSUBH — Maximum Vertical Spacing for Rows of U-Channel Bridging (ft.) (cont.)

Stud Spacing (in.)	Stud Section	Stud Thickness mil (ga.)	Lateral Stud Pressure (psf)																							
			5		10		15		20		25		30		35		40		45		50					
			Min.	Max.	Min.	Max.	Min.	Max.	Min.	Max.	Min.	Max.	Min.	Max.	Min.	Max.	Min.	Max.	Min.	Max.	Min.	Max.				
24	362S162	54 (16)	8	8	8	8	8	8	8	8	8	8	8	8	8	8	8	8	8	8	8	8	8			
		68 (14)	8	8	8	8	8	8	8	8	8	8	8	8	8	8	8	8	8	8	8	8	8	8		
		97 (12)	8	8	8	8	8	8	8	8	8	8	8	8	8	8	8	8	8	8	8	8	8	8	8	
	362S200	54 (16)	8	8	8	8	8	8	8	8	8	7	8	6	8	5	7	4	6	4	5	—	5			
		68 (14)	8	8	8	8	8	8	8	8	8	8	8	7	8	6	8	5	7	4	6	4	5			
		97 (12)	8	8	8	8	8	8	8	8	8	8	8	7	8	6	8	5	7	5	6	4	5			
	362S250	54 (16)	8	8	8	8	8	8	8	7	8	5	8	4	7	4	6	—	5	—	4	—	4			
		68 (14)	8	8	8	8	8	8	8	8	6	8	5	7	4	6	4	6	—	5	—	5	—	4		
		97 (12)	8	8	8	8	8	8	8	8	7	8	6	7	5	6	4	5	4	5	—	4	—	4		
	600S162	54 (16)	8	8	8	8	8	8	8	8	8	8	8	8	8	8	8	8	8	7	8	6	8	5	8	
		68 (14)	8	8	8	8	8	8	8	8	8	8	8	8	8	8	8	8	8	7	8	7	8	6	8	
		97 (12)	8	8	8	8	8	8	8	8	8	8	8	8	8	8	8	8	8	8	8	8	8	7	8	
	600S200	54 (16)	8	8	8	8	8	8	8	8	8	8	7	8	6	8	5	8	4	7	4	6	—	4	6	
		68 (14)	8	8	8	8	8	8	8	8	8	8	8	8	8	7	8	6	8	5	7	4	6	—	4	
		97 (12)	8	8	8	8	8	8	8	8	8	8	8	8	8	7	8	6	8	5	8	5	8	5	7	
	600S250	54 (16)	8	8	8	8	8	8	8	8	6	8	5	8	4	7	4	6	—	5	—	5	—	5		
		68 (14)	8	8	8	8	8	8	8	8	7	8	6	8	5	7	4	6	4	6	—	4	6	—	5	
		97 (12)	8	8	8	8	8	8	8	8	8	6	8	5	8	5	7	4	6	4	6	—	4	6	—	
	800S162	54 (16)	8	8	8	8	8	8	8	8	8	8	8	8	8	8	8	8	7	8	6	8	8	6	8	
		68 (14)	8	8	8	8	8	8	8	8	8	8	8	8	8	8	8	8	8	8	8	8	8	8	7	8
		97 (12)	8	8	8	8	8	8	8	8	8	8	8	8	8	8	8	8	8	8	8	8	8	8	7	8
	800S200	54 (16)	8	8	8	8	8	8	8	8	8	8	7	8	6	8	5	8	5	8	4	7	—	4	7	
		68 (14)	8	8	8	8	8	8	8	8	8	8	8	8	7	8	6	8	5	8	5	8	5	7	—	
		97 (12)	8	8	8	8	8	8	8	8	8	8	8	8	8	8	7	8	6	8	5	8	5	7	—	
800S250	54 (16)	8	8	8	8	8	8	8	8	7	8	5	8	5	8	4	7	—	6	—	5	—	5			
	68 (14)	8	8	8	8	8	8	8	8	8	8	6	8	5	8	5	7	4	6	4	6	—	4	6		
	97 (12)	8	8	8	8	8	8	8	8	8	8	7	8	6	8	5	7	4	7	4	7	4	6	—		
1000S162	54 (16)	—	8	—	8	—	8	—	8	—	8	—	8	—	8	—	8	—	8	—	8	—	8	—		
	68 (14)	—	8	—	8	—	8	—	8	—	8	—	8	—	8	—	8	—	8	—	8	—	8	—		
	97 (12)	—	8	—	8	—	8	—	8	—	8	—	8	—	8	—	8	—	8	—	8	—	8	—		
1000S200	54 (16)	—	8	—	8	—	8	—	8	—	8	—	8	—	8	—	8	—	8	—	8	—	8	—		
	68 (14)	—	8	—	8	—	8	—	8	—	8	—	8	—	8	—	8	—	8	—	8	—	8	—		
	97 (12)	—	8	—	8	—	8	—	8	—	8	—	8	—	8	—	8	—	8	—	8	—	8	—		
1000S250	54 (16)	—	8	—	8	—	8	—	8	—	8	—	8	—	8	—	7	—	6	—	5	—	5			
	68 (14)	—	8	—	8	—	8	—	8	—	8	—	8	—	8	—	7	—	6	—	5	—	5			
	97 (12)	—	8	—	8	—	8	—	8	—	8	—	8	—	8	—	7	—	6	—	5	—	5			
1200S162	54 (16)	—	8	—	8	—	8	—	8	—	8	—	8	—	8	—	8	—	8	—	8	—	8	—		
	68 (14)	—	8	—	8	—	8	—	8	—	8	—	8	—	8	—	8	—	8	—	8	—	8	—		
	97 (12)	—	8	—	8	—	8	—	8	—	8	—	8	—	8	—	8	—	8	—	8	—	8	—		
1200S200	54 (16)	—	8	—	8	—	8	—	8	—	8	—	8	—	8	—	8	—	8	—	8	—	8	—		
	68 (14)	—	8	—	8	—	8	—	8	—	8	—	8	—	8	—	8	—	8	—	8	—	8	—		
	97 (12)	—	8	—	8	—	8	—	8	—	8	—	8	—	8	—	8	—	8	—	8	—	8	—		
1200S250	54 (16)	—	8	—	8	—	8	—	8	—	8	—	8	—	8	—	7	—	6	—	6	—	6	—		
	68 (14)	—	8	—	8	—	8	—	8	—	8	—	8	—	8	—	7	—	6	—	6	—	6	—		
	97 (12)	—	8	—	8	—	8	—	8	—	8	—	8	—	8	—	7	—	7	—	7	—	6	—		

C-CF-2020 © 2020 SIMPSON STRONG-TIE COMPANY INC.

Bridging and Bracing Connectors

1. See General Information and Notes on pp. 14–15 and 22.
2. Tabulated solutions are for ASD lateral pressure. Contact Simpson Strong-Tie for LRFD solutions.
3. Lateral pressure shall be determined based on load combinations of the applicable code. For designs in accordance with the 2009 IBC and earlier, wind pressures are at working stress level and may be used directly. For designs in accordance with the 2012 IBC and later, wind pressures are at strength level and must be multiplied by 0.6 for ASD load combinations.
4. "Min." designates a solution with the minimum number of fasteners ((1) #10 screw installed in round hole). "Max." designates a solution requiring the maximum number of fasteners ((2) #10 screws; fill both round and triangle holes). Blank areas designate conditions where the MSUBH does not offer a solution.

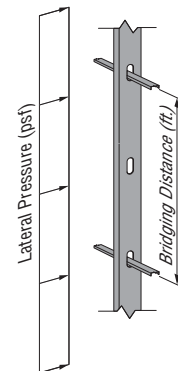

SUBH Bridging Connectors

Example #1: Curtain-Wall Stud

Given

- 2015 IBC (ASCE 7-10 and AISI S100-2012)
- 600S162-43 (33 ksi) studs at 24" o.c.
- 10'-tall studs with mid-point bracing (5' o.c.)
- Wind design pressure = 41 psf

Select Connector Using Design Table (p. 125)

ASD wind pressure:

$$p = (0.6)(41 \text{ psf}) = 24.6 \text{ psf}$$

Note: 2015 IBC load combinations for ASD include a factor of 0.6 for wind loads.

For 600S162-43 stud with SUBH3.25 connector, and 25 psf wind pressure with 5' bracing distance:

➔ SUBH3.25 with Min. fasteners **OK**

Notes

1. Only lateral load has been included for clarity. Design of curtain-wall studs should consider load combinations with vertical load in accordance with the applicable building code (see Example #2).
2. Bridging connector may also be designed using Allowable Loads table on p. 123 (see Example #2).

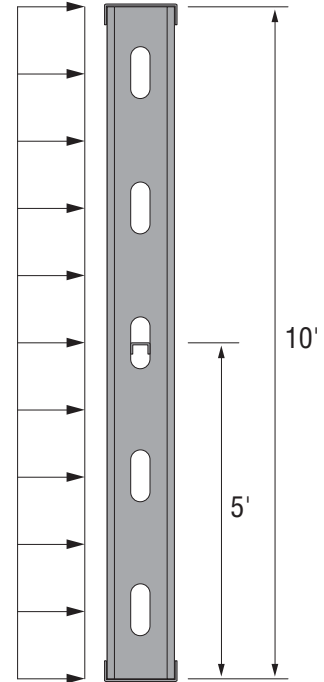

Example #2: Exterior Bearing-Wall Stud

Given

- 2015 IBC (ASCE 7-10 and AISI S100-2012)
- 600S162-54 (50 ksi) studs at 24" o.c., 10' tall
Mid-point bracing (5' o.c.)
Required axial stud strength, $P_{ra} = 2,200 \text{ lb.}$
Distance from shear center to mid-plane of web, $m = 0.663''$ (2013 AISI Manual, Table I-2)
- Wind design pressure = 34 psf

Axially-Loaded Stud Design

Required brace strength (AISI S100 Eq. D3.3-1):

$$P_{br,1} = 0.01P_{ra} = (0.01)(2,200 \text{ lb.}) = 22 \text{ lb.}$$

Required brace stiffness (AISI S100 Eq. D3.3-2a):

$$\beta_{rb} = \{2[4 - (2/n)]/L_b\} \Omega P_{ra} = \{2[4 - (2/1)]/60 \text{ in.}\} (2)(2,200) = 294 \text{ lb./in.}$$

From Allowable Loads table (p. 123) for 6"-deep 54-mil stud:

- ➔ Select SUBH3.25 with Min. fasteners
Allowable brace strength = 275 lb. > 22 lb. **OK**
Brace stiffness = 1,130 lb./in. > 294 lb./in. **OK**

Laterally-Loaded Stud Design

Design load tributary to a single connector:

$$W = (0.6)(34 \text{ psf})(2 \text{ ft.})(5 \text{ ft.}) = 204 \text{ lb.}$$

Note: 2015 IBC load combinations for ASD include a factor of 0.6 for wind loads.

Required flange force (AISI S100 Eq. D3.2.1-3):

$$P_{L1} = -P_{L2} = 1.5(m/d)W = (1.5)(0.663 \text{ in.}/6 \text{ in.})(204 \text{ lb.}) = 33.8 \text{ lb.}$$

Torsional moment:

$$M_z = P_{L1}d = -P_{L2}d = (33.8 \text{ lb.})(6 \text{ in.}) = 203 \text{ in.-lb.}$$

From Allowable Loads table (p. 123) for 6"-deep 54-mil stud:

- ➔ Select SUBH3.25 with Min. fasteners
Allowable torsional moment = 350 in.-lb. > 203 in.-lb. **OK**

Combined-Loading Check

$$(P_{br,1}/\text{Allowable brace strength}) + (M_z/\text{Allowable torsional moment}) = (22 \text{ lb.}/275 \text{ lb.}) + (203 \text{ in.-lb.}/350 \text{ in.-lb.}) = 0.66 < 1.0 \text{ **OK**}$$