

THGB/THGBH/THGW/THGBV/THGBHV/THGWV

Truss and SCL-to-Truss Girder Hangers

These high-capacity, welded hangers are designed for attaching two-ply, three-ply or four-ply-sized structural composite lumber (SCL) and multi-ply girder trusses to a girder truss.

The THGBV and THGB offer optional installation with Strong-Drive® SDS Heavy-Duty Connector screws, while the bolted THGBHV, THGWV, THGBH and THGW offer higher load capacities.

For the THGBV/THGBHV/THGWV series, two bucket heights are available for each width to accommodate a range of SCL sizes. Options for skewing or dropping the buckets for conditions where the SCL joist is lower than the girder bottom chord provide additional design flexibility for a variety of SCL-to-truss connections.

See the THGQ/THGQH series for a lower-cost alternative that uses Strong-Drive SDS Heavy-Duty Connector screws instead of bolts and offers high-load capacities.

Material: 3 gauge

Finish: Simpson Strong-Tie gray paint

Installation:

- Use all specified fasteners; see General Notes.
- All multiple members must be fastened together to act as a single unit.
- Maximum 117/8" bottom chord in the carrying member to allow for the minimum bolt end distance.
- Bolts must be installed symmetrically when using fewer than eight bolts on the eight-bolt backplate.
- Girders must be adequately laterally braced to prevent excessive displacement due to secondary torsional stresses (Ref. ANSI/TPI 1-2014 Section 7.5.3.5).
- Shall be attached to a two-ply girder truss to allow for required minimum screw penetration. See footnote 4.

Options:

Skewed Seat

- THGB/THGBH/THGBV/THGBHV hangers can be skewed to a maximum of 45°. The maximum allowable down load and uplift load for skew is 0.87 of the table load.

Dropped Bucket

- THGBV/THGBHV backplates can be extended to allow for up to a 6" dropped bucket.
- Allowable loads are 100% of the table loads.
- Order as "X" version, specify the total backplate height, BK_PLT, equal to the hanger height (H) plus the dropped bucket amount (d_b). Ex: a THGBV3.62/9 with a 4" dropped bucket would have a total backplate height of 27 1/4".

Codes: See p. 11 for Code Reference Key Chart

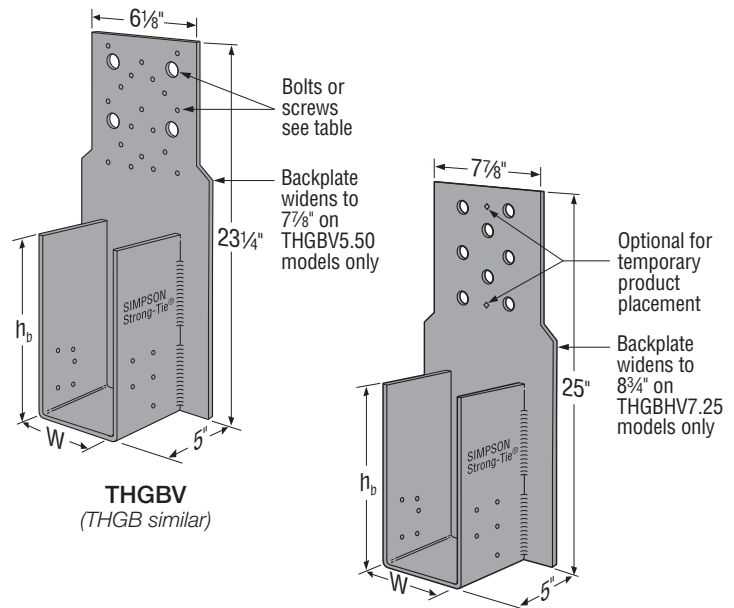

THGB
(THGB similar)

THGBHV
(THGBH similar)

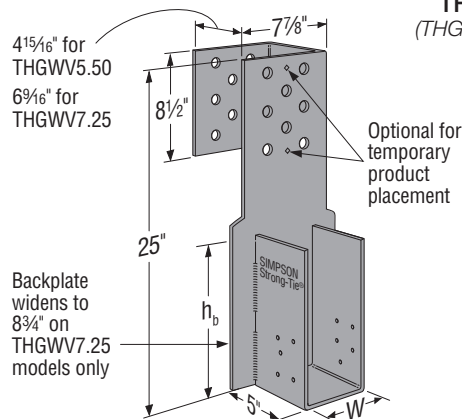

THGW
(THGW similar)

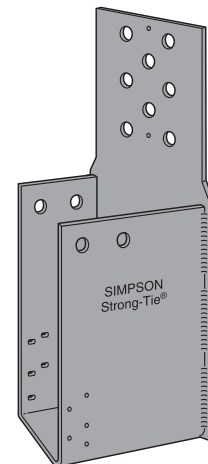

THGBH3
(skewed left)

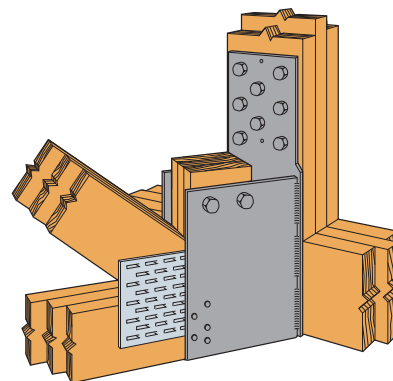

Typical THGBH Installation
Skewed Left

THGB/THGBH/THGW/THGBV/THGBHV/THGWV

Truss and SCL-to-Truss Girder Hangers (cont.)

Joist Dimensions (in.)		Model No.	Hanger Dimensions (in.)	
Width	Depth		W	h _b
3½	9¼ – 14	THGBV3.62/9	3½	9
		THGBHV3.62/9		
	11¼ – 20	THGBV3.62/11		11
		THGBHV3.62/11		
5¼	9¼ – 14	THGBV5.50/9	5½	9
		THGBHV5.50/9		
		THGWV5.50/9		
	11¼ – 20	THGBV5.50/11		11
		THGBHV5.50/11		
		THGWV5.50/11		
7	9¼ – 14	THGBHV7.25/9	7¼	9
		THGWV7.25/9		
	11¼ – 20	THGBHV7.25/11		11
		THGWV7.25/11		

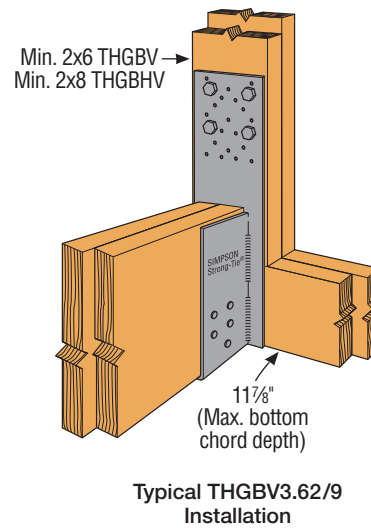
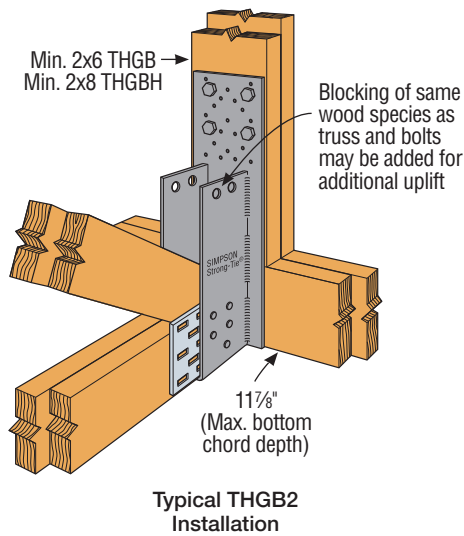
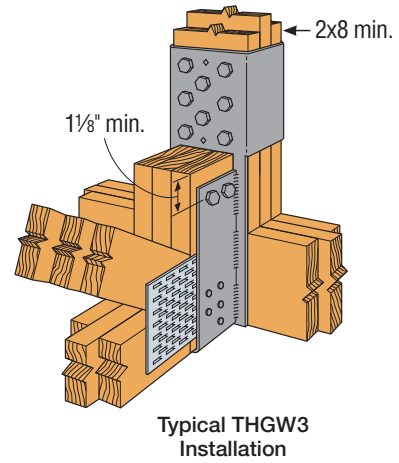

THGB/THGBH/THGW/THGBV/THGBHV/THGWV

Truss and SCL-to-Truss Girder Hangers (cont.)

Plated Truss Connectors

Model No.	Beam Width (in.)	Fasteners (in.)		Length of Bolt in Carrying Member	DF/SP Allowable Loads					SPF/HF Allowable Loads					Code Ref.
		Carried Member	Carrying Member		Uplift (160)	Floor (100)	Snow (115)	Roof (125)	Wind (160)	Uplift (160)	Floor (100)	Snow (115)	Roof (125)	Wind (160)	
THGBV3.62/9 THGBV3.62/11	3½	(10) 0.148 x 3	(4) ¼ MB	3	2,570	6,030	6,835	7,375	8,715	2,570	5,160	5,840	6,290	7,320	
				4½		6,910	7,780	8,350	8,715		6,385	7,185	7,320	7,320	
				6		6,910	7,780	8,350	8,715		6,400	7,200	7,320	7,320	
			(19) ¼ x 3 SDS	—		7,980	8,675	8,675	8,675		5,700	6,245	6,245	6,245	
THGBHV3.62/9 THGBHV3.62/11	3½	(10) 0.148 x 3	(8) ¼ MB	3	2,570	10,105	10,345	10,505	10,915	2,570	7,465	7,675	7,815	8,285	
				4½		10,915	10,915	10,915	10,915		9,165	9,165	9,165	9,165	
				6		10,915	10,915	10,915	10,915		9,165	9,165	9,165	9,165	
THGBV5.50/9 THGBV5.50/11	5¼	(10) 0.148 x 3	(4) ¼ MB	3	2,570	6,030	6,835	7,375	8,715	2,570	5,160	5,840	6,290	7,320	
				4½		6,910	7,780	8,350	8,715		6,385	7,185	7,320	7,320	
				6		6,910	7,780	8,350	8,715		6,400	7,200	7,320	7,320	
			(19) ¼ x 3 SDS	—		7,980	8,675	8,675	8,675		5,700	6,245	6,245	6,245	
THGBHV5.50/9 THGBHV5.50/11	5¼	(10) 0.148 x 3	(8) ¼ MB	3	2,570	10,915	10,915	10,915	10,915	2,570	9,165	9,165	9,165	9,165	
				4½		12,665	12,665	12,665	12,665		10,500	10,640	10,640	10,640	
				6		12,815	12,815	12,815	12,815		10,500	10,710	10,765	10,765	
THGBHV7.25/9 THGBHV7.25/11	7	(10) 0.148 x 3	(4) ¼ MB	3	2,570	6,040	6,850	7,390	8,715	2,570	5,165	5,845	6,295	7,320	
				4½		6,910	7,780	8,350	8,715		6,385	7,185	7,320	7,320	
				6		6,910	7,780	8,350	8,715		6,400	7,200	7,320	7,320	
THGBHV7.25/9 THGBHV7.25/11	7	(10) 0.148 x 3	(6) ¼ MB	3	2,570	9,065	10,010	10,010	10,010	2,570	7,750	8,410	8,410	8,410	
				4½		10,010	10,010	10,010	10,010		8,410	8,410	8,410	8,410	
				6		10,010	10,010	10,010	10,010		8,410	8,410	8,410	8,410	
THGBHV7.25/9 THGBHV7.25/11	7	(10) 0.148 x 3	(8) ¼ MB	3	2,570	10,915	10,915	10,915	10,915	2,570	9,165	9,165	9,165	9,165	
				4½		13,830	15,060	15,060	15,060		12,650	12,650	12,650	12,650	
				6		13,830	15,060	15,060	15,060		12,650	12,650	12,650	12,650	
THGWV5.50/9 THGWV5.50/11	5¼	(10) 0.148 x 3	(8) ¼ MB	4½	2,570	21,320	21,835	21,835	21,835	2,570	18,340	18,340	18,340	18,340	
THGWV7.25/9 THGWV7.25/11	7	(10) 0.148 x 3	(8) ¼ MB	6	2,570	24,165	24,165	24,165	24,165	2,570	20,300	20,300	20,300	20,300	

1. Allowable loads are based on a SCL (LVL, PSL, or LSL) carried member with an allowable $F'_{c\perp}$ of 750 psi and equivalent Specific Gravity of 0.50 or higher.
2. Uplift loads have been increased for earthquake or wind loading with no further increase allowed. Reduce where other loads govern.
3. A three-ply carrying member is required for the THGWV5.50/9 and THGWV5.50/11; a four-ply carrying member is required for the THGWV7.25/9 and THGWV7.25/11.
4. Strong-Drive® SDS Heavy-Duty Connector screws require a minimum two-ply (3") carrying member.
5. Bolts and Strong-Drive SDS Heavy-Duty Connector screws (not included) may be installed through metal truss connector plates as approved by the Truss Designer, provided the requirements of ANSI/TPI 1-2014, Sections 7.5.3.4 and 8.9.2 are met.
6. Wind (160) is a download rating.
7. To achieve published loads, install bolts into the girder truss with the nut on the opposite side of the hanger with a standard-cut washer (except THGWVs). Standard-cut washers are required for THGBV and THGBHV.
8. **Fasteners:** Nail dimensions are listed diameter by length. SDS screws are Simpson Strong-Tie® Strong-Drive SDS Heavy-Duty Connector screws. See pp. 21–22 for fastener information.

THGB/THGBH/THGW/THGBV/THGBHV/THGWV

Truss and SCL-to-Truss Girder Hangers (cont.)

Model No.	Width (W) (in.)	Fasteners (in.)		Length of Bolt in Carrying Member	DF/SP Allowable Loads					SPF/HF Allowable Loads					Code Ref.				
		Carried Member	Carrying Member		Uplift (160)	Floor (100)	Snow (115)	Roof (125)	Wind (160)	Uplift (160)	Floor (100)	Snow (115)	Roof (125)	Wind (160)					
THGB2	3 ⁵ / ₁₆	(10) 0.148 x 3 and (2) 3/4 MB	(4) 3/4 MB	3	9,250	6,030	6,840	7,375	9,250	7,765	5,160	5,845	6,290	7,770	FL				
				4 1/2	9,700	6,915	7,780	8,350	9,350	8,145	6,390	7,185	7,320	7,855					
				6	9,700	6,915	7,780	8,350	9,350	8,145	6,405	7,200	7,320	7,855					
THGB2	3 ⁵ / ₁₆	(10) 0.148 x 3 and (2) 3/4 MB	(19) 1/4 x 3 SDS	—	9,510	7,980	9,175	9,510	9,510	6,845	5,700	6,605	6,845	6,845					
				THGBH2	3 ⁵ / ₁₆	(10) 0.148 x 3 and (2) 3/4 MB	(8) 3/4 MB	3	9,700	10,105	10,345	10,505	10,915	8,145		7,465	7,675	7,815	8,285
								4 1/2	9,700	10,105	10,345	10,505	10,915	8,145		8,490	8,690	8,825	9,165
6	9,700	10,105	10,345					10,505	10,915	8,145	8,490	8,690	8,825	9,165					
THGB3	4 ¹ / ₁₆	(10) 0.148 x 3 and (2) 3/4 MB	(4) 3/4 MB	3	9,250	6,030	6,840	7,375	9,250	7,765	5,160	5,845	6,290	7,770					
				4 1/2	9,700	6,915	7,780	8,350	9,350	8,145	6,390	7,185	7,320	7,855					
				6	9,700	6,915	7,780	8,350	9,350	8,145	6,405	7,200	7,320	7,855					
THGB3	4 ¹ / ₁₆	(10) 0.148 x 3 and (2) 3/4 MB	(19) 1/4 x 3 SDS	—	9,510	7,980	9,175	9,510	9,510	6,845	5,700	6,605	6,845	6,845					
				THGBH3	4 ¹ / ₁₆	(10) 0.148 x 3 and (2) 3/4 MB	(8) 3/4 MB	3	9,700	10,915	10,915	10,915	10,915	8,145		9,165	9,165	9,165	9,165
								4 1/2	9,700	12,665	12,665	12,665	12,665	8,145		10,500	10,640	10,640	10,640
6	9,700	12,815	12,815					12,815	12,815	8,145	10,500	10,710	10,765	10,765					
THGBH4	6 ⁹ / ₁₆	(10) 0.148 x 3 and (2) 3/4 MB	(4) 3/4 MB	3	9,270	6,040	6,850	7,390	9,270	7,785	5,165	5,845	6,295	7,785					
				4 1/2	9,700	6,915	7,780	8,350	9,350	8,145	5,810	7,185	7,320	7,855					
				6	9,700	6,915	7,780	8,350	9,350	8,145	5,810	7,200	7,320	7,855					
THGBH4	6 ⁹ / ₁₆	(10) 0.148 x 3 and (2) 3/4 MB	(6) 3/4 MB	3	9,700	9,065	10,010	10,010	10,010	8,145	7,750	8,410	8,410	8,410					
				4 1/2	9,700	10,010	10,010	10,010	10,010	8,145	8,410	8,410	8,410	8,410					
				6	9,700	10,010	10,010	10,010	10,010	8,145	8,410	8,410	8,410	8,410					
THGBH4	6 ⁹ / ₁₆	(10) 0.148 x 3 and (2) 3/4 MB	(8) 3/4 MB	3	9,700	10,915	10,915	10,915	10,915	8,145	9,165	9,165	9,165	9,165					
				4 1/2	9,700	13,830	15,060	15,060	15,060	8,145	12,650	12,650	12,650	12,650					
				6	9,700	13,830	15,060	15,060	15,060	8,145	12,650	12,650	12,650	12,650					
THGW3-3 ⁶	4 ¹ / ₁₆	(10) 0.148 x 3 and (2) 3/4 MB	(8) 3/4 MB	4 1/2	9,700	20,630	20,630	20,630	20,630	8,145	17,330	17,330	17,330	17,330					
THGW3-4 ⁶				6	9,700	20,630	20,630	20,630	20,630	8,145	17,330	17,330	17,330	17,330					
THGW4-3 ⁶	6 ⁹ / ₁₆	(10) 0.148 x 3 and (2) 3/4 MB	(8) 3/4 MB	4 1/2	9,700	22,840	22,840	22,840	22,840	8,145	19,185	19,185	19,185	19,185					
THGW4-4 ⁶				6	9,700	22,840	22,840	22,840	22,840	8,145	19,185	19,185	19,185	19,185					

- Uplift loads have been increased for earthquake or wind loading with no further increase allowed. Reduce where other loads govern.
- A three-ply carrying member is required for the THGW3-3 and THGW4-3; a four-ply carrying member is required for the THGW3-4 and THGW4-4. For all other models, a minimum two-ply carrying member is required.
- Strong Drive® SDS Heavy-Duty Connector screws require a minimum two-ply (3") carrying member.
- Bolts and Strong Drive SDS Heavy-Duty Connector screws (not included) may be installed through metal truss connector plates as approved by the Truss Designer, provided the requirements of ANSI/TPI 1-2014, Sections 7.5.3.4 and 8.9.2 are met.
- (10) 0.148" x 3" nails for the carried member will achieve the maximum downloads. Uplift loads are 2,570 lb. for DF/SP and 2,210 lb. for SPF/HF. To achieve maximum uplift, install nails and bolts listed in the table.
- Loads for THGW models require that the supported member have minimum 2x6 end verticals to ensure end-grain bearing. Contact Simpson Strong-Tie for loads when horizontal members are bearing in the hanger seat.
- Wind (160) is a download rating.
- To achieve published loads, install bolts into the girder truss with the nut on the opposite side of the hanger with a standard-cut washer (except THGWs). Standard-cut washers are required for THGB and THGBH.
- Fasteners:** Nail dimensions are listed diameter by length. SDS screws are Simpson Strong-Tie® Strong-Drive SDS Heavy-Duty Connector screws. See pp. 21–22 for fastener information.