

Trubolt+ Seismic Wedge



SPECIFIED FOR ANCHORAGE INTO CONCRETE

Trubolt+ seismic wedge anchors consist of a high-strength threaded stud body, expansion clip, nut and washer. Anchor bodies are made of plated carbon steel. The expansion clip consists of a split cylindrical ring with undercutting grooves.

The exposed end of the anchor is stamped to identify anchor length. Stampings should be preserved during installation for any subsequent embedment verification.

Use carbide tipped hammer drill bits made in accordance with ANSI B212.15-1994 to install anchors.



Anchors are tested to ACI 355.2 and ICC-ES AC193. Anchors are listed by the following agencies as required by the local building code: ICC-ES and City of Los Angeles.

See pages 46-47 for performance values in accordance to 2006 IBC.

INSTALLATION STEPS

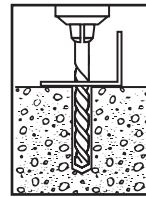

1. Select a carbide drill bit with a diameter equal to the anchor diameter. Drill hole to any depth exceeding the desired embedment. See chart for minimum recommended embedment.

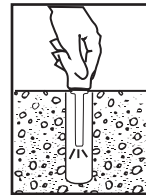

2. Clean hole or continue drilling additional depth to accommodate drill fines.



3. Assemble washer and nut, leaving nut flush with end of anchor to protect threads. Drive anchor through material to be fastened until washer is flush to surface of material.

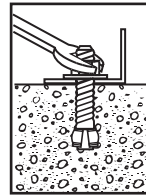

4. Expand anchor by tightening nut 3-5 turns past the hand tight position, or to the specified torque requirement.

APPROVALS/LISTINGS



ICC Evaluation Service, Inc. # ESR-2427

- Category 1 performance rating
- 2006 IBC and 2009 IBC compliant
- Meets ACI 318 ductility requirements
- Tested in accordance with ACI 355.2 and ICC-ES AC193
- Listed for use in seismic zones A, B, C, D, E, & F
- 3/8", 1/2", 5/8" & 3/4" diameter anchors listed in ESR-2427

City of Los Angeles - #RR25867

Florida Building Code FL#14419.2

Patents US 7,811,037 B2 and US 7,744,320 B2

LENGTH INDICATION CODE *

CODE	LENGTH OF ANCHOR	CODE	LENGTH OF ANCHOR
A	1-1/2 < 2 (38.1 < 50.8)	K	6-1/2 < 7 (165.1 < 177.8)
B	2 < 2-1/2 (50.8 < 63.5)	L	7 < 7-1/2 (177.8 < 190.5)
C	2-1/2 < 3 (63.5 < 76.2)	M	7-1/2 < 8 (190.5 < 203.2)
D	3 < 3-1/2 (76.2 < 88.9)	N	8 < 8-1/2 (203.2 < 215.9)
E	3-1/2 < 4 (88.9 < 101.6)	O	8-1/2 < 9 (215.9 < 228.6)
F	4 < 4-1/2 (101.6 < 114.3)	P	9 < 9-1/2 (228.6 < 241.3)
G	4-1/2 < 5 (114.3 < 127.0)	Q	9-1/2 < 10 (241.3 < 254.0)
H	5 < 5-1/2 (127.0 < 139.7)	R	10 < 11 (254.0 < 279.4)
I	5-1/2 < 6 (139.7 < 152.4)	S	11 < 12 (279.4 < 304.8)
J	6 < 6-1/2 (152.4 < 165.1)	T	12 < 13 (304.8 < 330.2)

*Located on top of anchor for easy inspection.

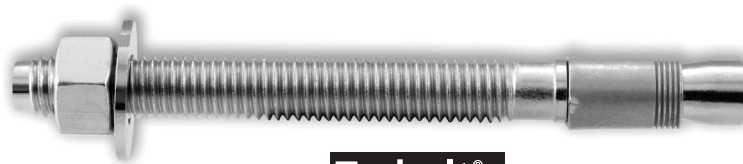

Trubolt+ & OVERHEAD Trubolt+

Strength Design Performance values in accordance to 2006 and 2009 IBC

ITW RED HEAD TRUBOLT+ and OVERHEAD TRUBOLT+ EDGE ANCHOR DESIGN INFORMATION TESTED TO ICC-ES AC 193 AND ACI 355.2, IN ACCORDANCE WITH 2006 and 2009 IBC



TRUBOLT+ AND OVERHEAD TRUBOLT+ WEDGE ANCHOR DESIGN INFORMATION¹

Characteristic	Symbol	Units	Nominal Anchor Diameter (inch) ⁴							
			3/8"		1/2"		5/8"		3/4"	
Anchor category	1, 2 or 3	—	1		1		1		1	
Minimum effective embedment depth	h_{ef}	in	1-5/8		2		3-1/4		2-3/4 4-1/4 3-3/4	
Minimum concrete member thickness	h_{min}	in	4	5	4	6	6	8	6	6-1/4 7 8
Critical edge distance	c_{ac}	in	5	3	6	6	7-1/2	6	7-1/2	6-1/2 12 10
Data for Steel Strengths – Tension and Shear										
Minimum specified yield strength	f_y	psi	60,000		55,000		55,000		55,000	
Minimum specified ultimate strength	f_{uta}	psi	75,000		75,000		75,000		75,000	
Effective tensile stress area (neck)	A_{se}	in ²	0.056		0.119		0.183		0.266	
Effective tensile stress area (thread)	A_{se}	in ²	0.075		0.142		0.217		0.332	
Steel strength in tension	N_{sa}	lbf	4,200		8,925		13,725		19,950	
Steel strength in shear, uncracked or cracked concrete ⁶	V_{sa}	lbf	1,830		5,175		8,955		14,970	
Steel strength in shear – seismic loads	V_{eq}	lbf	1,545		5,175		8,955		11,775	
Strength reduction factor f for tension, steel failure modes ²			0.75		0.75		0.75		0.75	
Strength reduction factor f for shear, steel failure modes ²			0.60		0.65		0.65		0.65	
Data for Concrete Breakout Concrete Pryout Strengths in Tension and Shear										
Effectiveness factor – uncracked concrete	k_{uncr}	—	24		24		24		24	
Effectiveness factor – cracked concrete	k_{cr}	—	17		17		17		17	
Modification factor for cracked and uncracked concrete ³	$\Psi_{C,N}$	—	1.0		1.0		1.0		1.0	
Coefficient for pryout strength	k_{cp}	—	1.0		1.0		2.0		2.0	
Load-bearing length of anchor	l_e	in	1.625		2.0		3.25		2.75 4.25 3.75	
Strength reduction factor ϕ for tension, concrete failure modes, Condition B ²			0.65		0.65		0.65		0.65	
Strength reduction factor ϕ for shear, concrete failure modes, Condition B ²			0.70		0.70		0.70		0.70	
Data for Pullout Strengths										
Pullout strength, uncracked concrete	$N_{p,uncr}$	lbf	See Footnote ⁵		See Footnote ⁵		6,540		5,430 8,900 See Footnote ⁵	
Pullout strength, cracked concrete	$N_{p,cr}$	lbf	See Footnote ⁵		See Footnote ⁵		See Footnote ⁵		See Footnote ⁵	
Pullout strength for seismic loads	N_{eq}	lbf	See Footnote ⁵		See Footnote ⁵		See Footnote ⁵		6,715 See Footnote ⁵	
Strength reduction factor f for tension, pullout failure modes, Condition B ²			See Footnote ⁵		0.65		0.65		See Footnote ⁵	
Additional Anchor Data										
Axial stiffness in service load range in uncracked concrete	b_{uncr}	lbf/in	100,000		250,000		250,000		250,000	
Axial stiffness in service load range in cracked concrete	b_{cr}	lbf/in	40,000		20,000		20,000		20,000	

For SI: 1 inch = 25.4 mm, 1 in² = 645.16mm², 1 lbf = 4.45 N, 1 psi = 0.006895 MPa, 1 lbf·in = 102/in - 17,500 N·m.

¹ The 1/2", 5/8" and 3/4" diameter Trubolt+ Wedge Anchors are ductile steel elements as defined by ACI 318 D.1. The 3/8" diameter Trubolt+ is considered ductile under tension loading and brittle under shear loading.

² All values of ϕ apply to the load combinations of IBC Section 1605.2, ACI 318 Section 9.2 or UBC Section 1612.2. If the load combinations of Appendix C or UBC Section 1909.2 are used, the appropriate value of ϕ must be determined in accordance with ACI 318 D.4.5. For installations where reinforcement that complies with ACI 318 Appendix D requirements for Condition A is present, the appropriate ϕ factor must be determined in accordance with ACI 318 D.4.4.

³ For all design cases $\Psi_{C,N} = 1.0$. The appropriate effectiveness factor for cracked concrete (k_{cr}) or uncracked concrete (k_{uncr}) must be used.

⁴ The actual diameter for the 3/8" diameter anchor is 0.361" for the 5/8" diameter anchor is 0.615" and the 3/4" diameter anchor is 0.7482".

⁵ Anchor pullout strength does not control anchor design. Determine steel and concrete capacity only.

⁶ Steel strength in shear values are based on test results per ACI 355.2, Section 9.4 and must be used for design.

TRUBOLT+ WEDGE ANCHOR (INSTALLED)

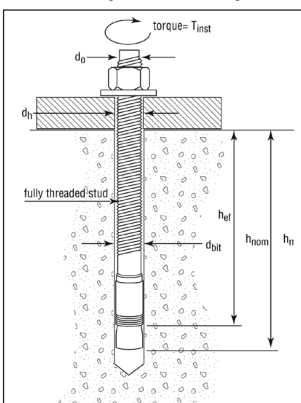

TRUBOLT+ AND OVERHEAD TRUBOLT+ WEDGE INSTALLATION INFORMATION

Parameter	Notation	Units	Nominal Anchor Diameter (inch)							
			3/8"		1/2"		5/8"		3/4"	
Anchor outer diameter	d_o	inches	0.361		0.5		0.615		0.7482	
Nominal carbide bit diameter	d_{bit}	inches	3/8		1/2		5/8		3/4	
Effective embedment depth	h_{ef}	inches	1-5/8		2 3-1/4		2-3/4 4-1/4		3-3/4	
Minimum anchor embedment depth	h_{nom}	inches	2		2-1/2 3-3/4		3-1/4 4-3/4		4-3/8	
Minimum hole depth ¹	h_o	inches	2-1/4		2-3/4 4		3-1/2 5		4-5/8	
Minimum concrete member thickness ¹	h_{min}	inches	4	5	4	6	6	8	6	6-1/4 7 8
Critical edge distance ¹	c_{ac}	In.	5	3	6	6	7-1/2	6	7-1/2	6-1/2 12 10
Minimum anchor spacing ¹	s_{min}	In.	3-1/2	2-1/2	6	5-3/4	4	5-3/4	8	6 6 6
Minimum edge distance ¹	c_{min}	In.	3		6		7-1/2		5 7-1/2 7-1/2	
Minimum overall anchor length	l	inches	2-1/2		3-3/4 4-1/2		4-1/4 6		5-1/2	
Installation torque	T_{inst}	ft-lb	30		45		90		110	
Minimum diameter of hole in fastened part	d_h	inches	1/2		5/8		3/4		7/8	

For SI: 1 inch = 25.4 mm, 1 ft-lb = 1.356 N·m.

Trubolt+ & OVERHEAD Trubolt+ Strength Design Performance values in accordance to 2006 and 2009 IBC

TRUBOLT+ AND OVERHEAD TRUBOLT+ WEDGE ANCHOR ALLOWABLE STRESS DESIGN (ASD) VALUES FOR ILLUSTRATIVE PURPOSES

Anchor Notation	Anchor Embedment Depth (inches), h_{nom}	Effective Embedment Depth (inches), h_{ef}	Allowable Tension Load (lbs)
3/8	2	1-5/8	1,090
1/2	2-1/2	2	1,490
	3-3/4	3-1/4	2,870
5/8	3-1/4	2-3/4	2,385
	4-3/4	4-1/4	3,910
3/4	4-3/8	3-3/4	3,825

For SI: 1 inch = 25.4 mm, 1 ft-lb = 4.45N.

Design Assumptions:

¹ Single anchor with static shear load only.

² Load combinations from 2006 IBC, Sections 1605.2.1 and 1605.3.1 (no seismic loading).

³ Thirty percent dead load and 70 percent live load, controlling load combination 1.2D + 1.6L

⁴ Calculation of weighted average: 1.2D + 1.6L = 1.2(0.3) + 1.6(0.7) = 1.48

⁵ Values do not include edge distance or spacing reductions.

ITW RED HEAD TRUBOLT+ and OVERHEAD TRUBOLT+ WEDGE ANCHOR DESIGN INFORMATION FOR INSTALLATION IN THE SOFFIT OF CONCRETE FILL ON METAL DECK FLOOR AND ROOF ASSEMBLIES

TRUBOLT+ AND OVERHEAD TRUBOLT+ WEDGE ANCHOR DESIGN INFORMATION

Characteristic	Symbol	Units	Nominal Anchor Diameter				
			3/8"	1/2"		5/8"	
			Upper /Lower $h_{ef} = 1-5/8"$	Upper /Lower $h_{ef} = 2"$	Lower Only $h_{ef} = 3-1/4"$	Lower Only $h_{ef} = 2-3/4"$	Lower Only $h_{ef} = 4-1/4"$
Pullout strength, uncracked concrete over metal deck	$N_{p, deck, uncr}$	lbf	2,170	2,515	5,285	3,365	6,005
Pullout strength, cracked concrete over metal deck	$N_{p, deck, cr}$	lbf	1,650	1,780	4,025	2,405	5,025
Reduction factor for pullout strength in tension, Condition B	ϕ	--	0.65				
Shear strength, uncracked concrete over metal deck	$V_{p, deck, uncr}$	lbf	1,640	2,200	3,790	2,890	6,560
Reduction factor for steel strength in shear	ϕ	--	0.60	0.65			
Anchor embedment depth	h_{nom}	in	2.0	2.5	3.75	3.25	4.75

For SI: 1 inch = 25.4 mm, 1 lbf = 4.45 N

Nominal Anchor Diameter = 3/8"

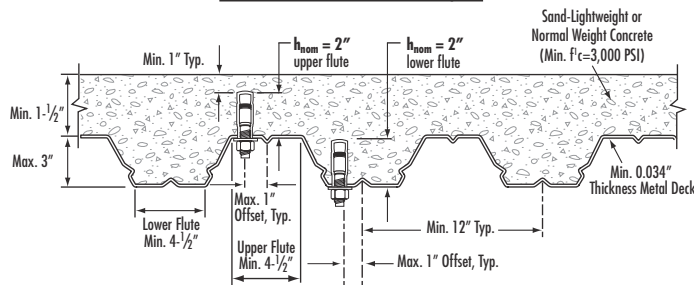

Nominal Anchor Diameter = 5/8"

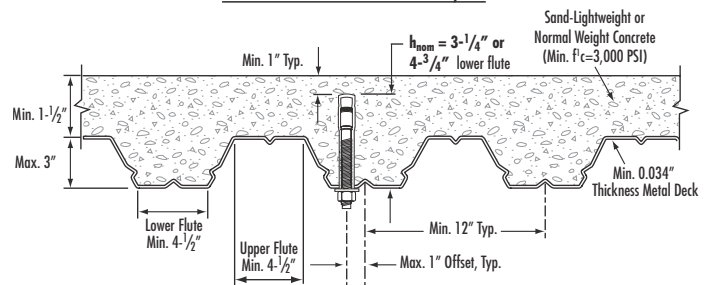

Nominal Anchor Diameter = 1/2"

