

# ICC-ES Evaluation Report

ESR-5283

Issued April 2026

This report also contains:



- [City of LA Supplement](#)

Subject to renewal April 2027

- [FL Supplement w/ HVHZ](#)

ICC-ES Evaluation Reports are not to be construed as representing aesthetics or any other attributes not specifically addressed, nor are they to be construed as an endorsement of the subject of the report or a recommendation for its use. There is no warranty by ICC Evaluation Service, LLC, express or implied, as to any finding or other matter in this report, or as to any product covered by the report.

Copyright © 2026 ICC Evaluation Service, LLC. All rights reserved.

<p><b>DIVISION: 06 00 00—</b> <b>WOOD, PLASTICS AND COMPOSITES</b></p> <p><b>Section: 06 05 23—</b> <b>Wood, Plastic, and Composite Fastenings</b></p>	<p><b>REPORT HOLDER:</b> <b>SIMPSON STRONG-TIE COMPANY, INC.</b></p> 	<p><b>EVALUATION SUBJECT:</b> <b>SIMPSON STRONG-TIE® Timber-SET™</b> <b>STRUCTURAL EPOXY ANCHORING ADHESIVE FOR TIMBER ROD CONNECTIONS</b></p>	
--	--	--	---

## 1.0 EVALUATION SCOPE

Compliance with the following codes:

- 2024, 2021 and 2018 [International Building Code® \(IBC\)](#)
- 2024, 2021 and 2018 [International Residential Code® \(IRC\)](#)

Property evaluated:

- Structural

## 2.0 USES

The Simpson Strong-Tie® Timber-SET™ Structural Epoxy Anchoring Adhesive system for timber rod connections is used to adhere threaded steel rods, also known as glued-in-rods (GIR), in timber elements. The GIRs installed in timber elements are designed to resist static, wind and seismic tension loads. The GIRs may also be used where an engineered design is submitted in accordance with Section R301.1.3 of the IRC.

## 3.0 DESCRIPTION

### 3.1 General:

The Timber-SET Structural Epoxy Anchoring Adhesive system is comprised of the following components:

- Timber-SET epoxy anchoring adhesive packaged in cartridges with adhesive mixing nozzle
- Dispensing equipment
- Equipment for hole cleaning, adhesive injections, and installation accessories
- Reinforcing screws (where required)
- A steel anchoring element

Timber-SET epoxy adhesive is used with continuously threaded steel rods. The manufacturer's printed installation instructions (MPII) are included with each adhesive unit package as shown in [Figure 9](#).

### 3.2 Materials:

**3.2.1 Timber-SET Structural Epoxy Anchoring Adhesive:** Timber-SET Structural Epoxy Anchoring Adhesive is an injectable, two-component, 100 percent solids, epoxy-based adhesive mixed as a 2-to-1 volume ratio of resin-to-hardener. Timber-SET is available in 32-ounce (946 mL) cartridges. The two components combine and react when dispensed through a static mixing nozzle attached to the cartridge.

The shelf life of Timber-SET in unopened cartridges is two years from the date of manufacture when stored at temperatures between 45°F and 90°F (7°C and 32°C) in accordance with the MPII.

- 3.2.2 Dispensing Equipment:** Timber-SET epoxy adhesive must be dispensed using Simpson Strong-Tie manual dispensing tools, battery-powered dispensing tools, or pneumatic dispensing tools as listed in [Table 6](#) of this report.
- 3.2.3 Hole Cleaning Equipment:** Hole cleaning equipment consists of hole-cleaning brushes and air nozzles. Brushes must be Simpson Strong-Tie hole cleaning brushes, identified by Simpson Strong-Tie catalog series ETB. See [Table 6](#) in this report, and the installation instructions shown in [Figure 9](#), for additional information. Air nozzles must be equipped with an extension capable of reaching the bottom of the drilled hole.
- 3.2.4 Anchor Materials: Threaded Steel Rods:** The threaded anchor rods having diameters of 1/2-, 5/8-, 3/4-, 7/8-, and 1-inch (12.7, 15.88, 19.05, 22.23, and 25.4mm) in diameter, must be carbon steel conforming to ASTM F1554, Grade 36 or 55. Threaded rods must be clean, straight, and free of indentations or other defects along their lengths and must be continuously threaded rod (all-thread) having thread characteristics complying with ANSI B1.1 UNC course thread series. Threaded steel rods are not provided with Timber-SET Structural Epoxy Anchoring Adhesive.
- 3.2.5 Wood Elements:** Wood elements must be Douglas Fir-Larch glued laminated timber (glulam). The glued laminated timber must have four or more laminations, a uniform (single) lay-up complying with Table 5B of the NDS Supplement, an assigned specific gravity,  $SG_{NDS}$ , of 0.50 or greater, and a maximum moisture content 16% in dry service conditions.
- 3.2.6 Reinforcing Screws:** SDCF8/SDCFC8 screws are Simpson Strong-Tie® Strong-Drive® SDCF TIMBER-CF8/TIMBER-CFC8 screws evaluated under ICC-ES ESR-3046. SDCF8/SDCFC8 screws, where required in this report, are not provided with Timber-SET Structural Epoxy Anchoring Adhesive.
- 3.2.7 Installation Accessories:** To limit adhesive from flowing out of the hole during installation, an adhesive retaining cap is required. To ensure the center of the back of the rod remains properly aligned, a rod end centering cap is required. Adhesive retaining caps and end rod centering caps must be Simpson Strong-Tie adhesive retaining caps and end rod centering caps, identified by Simpson Strong-Tie catalog series GARC and RECC, respectively. Adhesive piston plugs, and adhesive tubing are required for installation. Adhesive piston plugs and adhesive tubing must be Simpson Strong-Tie Piston Plugs and Adhesive tubing, identified by Simpson Strong-Tie catalog series PP and PPFT, respectively. See [Table 6](#) in this report, and the installation instructions shown in [Figure 9](#), for additional information.

## 4.0 DESIGN AND INSTALLATION

- 4.1 General:** Tabulated loads for single rods in tension for installation in timber elements are noted in [Table 3](#) and [Table 4](#) of this report. Reinforcing screws are required for all parallel to grain GIR applications, see [Figure 3](#) and [Figure 4](#) for reinforcing screw pattern and dimensional requirements. [Table 5](#) and [Figures 7](#) and [8](#) provide geometrical requirements for single rods and groups of rods.

For groups of rods, tabulated loads for single rods noted in [Table 3](#) and [Table 4](#) of this report can be multiplied by the number of rods in the group, provided the minimum geometric dimensions are met as noted in [Table 5](#) of this report. For groups of rods installed parallel to grain, groups of 4 and 6 rod increments are allowed (i.e. 4, 6, 8, 12, 16, 18, etc.); see [Figures 1, 2, 3, 4, and 7](#) for graphical visualization. For groups of rods installed perpendicular to grain, groups of 4 rod increments are allowed (i.e. 4, 8, 12, 16, etc.); see [Figures 5, 6 and 8](#) for graphical visualization.

The strengths for single rods or groups of rods shall be based on the least of the GIR strength and the steel strength. For seismic design in SDC C through F, the connection must be designed in accordance with ASCE 7-22 Section 12.4.3. The design seismic load effect shall be taken as the minimum of: (1) the seismic load effects including overstrength, and (2) the capacity-limited steel threaded rod strength,  $E_{cl}$ , as defined in ASCE 7-22 Section 11.3. Steel threaded rod minimum embedment depths for seismic design are noted in [Table 2](#). No reduction in strength is required for seismic applications. GIR connections must be designed by a registered design professional to distribute and develop the loads uniformly to each steel rod.

- 4.2 Allowable Stress Design:** The tabulated allowable loads shown in the product tables of this report are based on Allowable Stress Design (ASD) and include the load duration factor,  $C_D$ , corresponding with the applicable loads in accordance with the National Design Specification® for Wood Construction (NDS and its Supplement). Allowable steel strengths of threaded rods are noted in [Table 1](#). Allowable GIR strengths are noted in [Tables 3 and 4](#).
- 4.3 Load and Resistance Factor Design:** For use in Load and Resistance Factor Design (LRFD) the reference GIR design loads may be converted to LRFD using a Format Conversion Factor,  $K_F$ , of 3.32, a

resistance factor,  $\phi$ , of 0.65 and a time effect factor,  $\lambda$ , in accordance with Table N3.3 in Appendix N of the NDS. LRFD steel strength of threaded rods are noted in [Table 1](#) of this report. LRFD reference GIR design loads are noted in [Table 3](#) and [Table 4](#) of this report.

**4.4 Installation:** Installation parameters are provided in [Table 5](#) through [Table 8](#), and in [Figure 9](#). Anchor locations must comply with this report and the plans and specifications approved by the registered professional and must be installed under special inspection in accordance with Section 4.5 of this report. Installation of the Timber-SET Structural Epoxy Anchoring Adhesive must conform to the manufacturer's printed installation instructions (MPII) included in each package unit and as described in [Figure 9](#). The nozzles, brushes, dispensing tools, adhesive piston plugs, adhesive tubing, adhesive retaining caps and end rod centering caps listed in [Table 6](#), supplied by the manufacturer, must be used along with the adhesive cartridges. Reinforcing screws, where required, must be in accordance with Section 3.2.6 of this report.

Wood must have a maximum moisture content of 16% at time of installation and must be installed in dry service conditions.

The anchors may be installed in floor (vertically down) and wall (horizontal) installations. For all listed applications, adhesive piston plugs, adhesive tubing, adhesive retaining caps and end rod centering caps are required as described in [Table 6](#).

**4.5 Special Inspection:** Special inspection is required for fabricated items in accordance with IBC Section 1704.2.5. The special inspector must verify adhesive type, adhesive identification and expiration date, threaded rod dimensions, hole dimensions, hole cleaning, rod spacing and wood member minimum dimensions, and reinforcing screw type, size, spacing, and edge distances where required for adherence to the manufacturer's printed installation instructions as depicted in [Figure 9](#) of this report.

## 5.0 CONDITIONS OF USE:

The Simpson Strong-Tie® Timber-SET™ Structural Epoxy Anchoring Adhesive system also known as glued-in-rods (GIR) described in this report is a suitable alternative to what is specified in the codes listed in Section 1.0 of this report, subject to the following conditions:

- 5.1 Use and installation must be as set forth in this evaluation report, the Manufacturer's Published Installation Instructions (MPII) as depicted in [Figure 9](#), and the building plans approved by the building code official. In case of conflict, this report governs.
- 5.2 Calculations and details, justifying that the use of GIR in timber elements is in compliance with the evaluation report, must be submitted to the building code official for approval. The calculations must be prepared by a registered design professional where required by the statutes of the jurisdiction in which the project is to be constructed.
- 5.3 GIR connections may be used in structures assigned to Seismic Design Categories A through F under the IBC. In Seismic Design Categories (SDC) C through F GIR connections resisting short-term loading due to seismic forces must be capacity protected, limited to use in chords and collectors in wood diaphragms, and must not be used as the primary energy dissipating element.
- 5.4 The GIR in timber elements are limited to use in interior applications or be protected by cover in dry and well-ventilated areas, and a maximum moisture content of 16%, under a temperature of 110°F (43°C).
- 5.5 GIR in timber elements must be assembled in an indoor fabricator facility and are not to be installed at the project site. Special inspection is required for fabricated items in accordance with IBC Section 1704.2.5 and Section 4.5 of this report.
- 5.6 GIR longer than the published maximum bond lengths may be used provided the capacity of the GIR in timber element is limited to the values published in the ESR report.
- 5.7 GIR installed into timber elements installed at an angle other than parallel or perpendicular to grain is outside the scope of this report.
- 5.8 Overlap of GIR connections oriented perpendicular or at an angle to each other such that the timber element is subjected to combined loading is outside the scope of this report.
- 5.9 When glued-in rods are to be a component of fire-resistance-rated timber elements or assemblies, a report of testing or engineering analysis provided by a registered design professional shall be submitted to the building code official for their approval to demonstrate that the temperature at the adhesive does not exceed 110°F (43°C) to show that the required fire-resistance rated time period is not reduced. Where GIRs are installed in fire-resistance-rated wood structural assemblies, protection of the connections must be inspected in accordance with Sections 110.3.5 and 110.3.6 of the IBC, as applicable.

- 5.10 When the GIR in timber is used to resist axial compression loads, the allowable GIR load in compression may be equal to the allowable withdrawal strength in tension. Compression loads may be transferred to the timber element through full bearing on the mass timber element or through the steel rod only, provided the standoff of the steel rod is limited to a maximum of 1.5 times the nominal diameter. The standoff may be increased provided additional analysis in accordance with AISC 360 Section E3 is provided indicating that the steel rod does not govern in compression.
- 5.11 GIRs must not be installed on the underside of a wood structural element (overhead) or angled down from horizontal (upwardly inclined) such that the adhesive may flow out from the hole.
- 5.12 Timber-SET Structural Epoxy Anchoring Adhesive is manufactured and packaged into cartridges by Simpson Strong-Tie Company Inc., in West Chicago, Illinois, under a quality control program with inspections by ICC-ES.

## 6.0 EVIDENCE SUBMITTED

Data in accordance with the [ICC-ES Acceptance Criteria for Glued-In Rods in Wood Structural Elements, AC526 \(24\)](#), dated February 2026.

## 7.0 IDENTIFICATION

- 7.1 The ICC-ES mark of conformity, electronic labeling, or the evaluation report number (ICC-ES ESR-5283) along with the name, registered trademark, or registered logo of the report holder must be included in the product label.
- 7.2 In addition, the Timber-SET™ Structural Epoxy Anchoring Adhesive for timber rod connections are identified by a label displaying the product name, lot number, expiration date, a description of the product, and installation instructions. Threaded rods, nuts, washers are standard elements and must conform to applicable national or international specifications. Where reinforcing screws are required, see ICC-ES [ESR-3046](#).
- 7.3 The report holder's contact information is the following:

**SIMPSON STRONG-TIE COMPANY, INC.**  
**5956 WEST LAS POSITAS BOULEVARD**  
**PLEASANTON, CALIFORNIA 94588**  
**(800) 999-5099**  
[www.strongtie.com](http://www.strongtie.com)

TABLE 1 - STEEL DESIGN INFORMATION FOR THREADED ROD<sup>1,5</sup>

Rod Diameter (d)	Nominal Rod Diameter (d <sub>n</sub> )	Gross Area (A <sub>g</sub> )	R <sub>n</sub> Tension Reference Rod Load <sup>4</sup> (lb.)			
			ASTM F1554, Grade 36 <sup>2</sup>		ASTM F1554, Grade 55 <sup>3</sup>	
in.	in.	in. <sup>2</sup>	ASD	LRFD	ASD	LRFD
1/2	0.5	0.196	4,270	6,405	5,520	8,285
5/8	0.625	0.307	6,675	10,010	8,630	12,945
3/4	0.75	0.442	9,610	14,415	12,425	18,640
7/8	0.875	0.601	13,080	19,620	16,910	25,370
1	1	0.785	17,080	25,625	N/A	N/A

For SI: 1 inch = 25.4 mm, 1 ft-lb = 1.356 Nm.

<sup>1</sup>Capacities based on AISC 325 16<sup>th</sup> Edition, Part 16, J3.7

<sup>2</sup>ASTM F1554 Gr.36 properties used: F<sub>y</sub>=36ksi, and F<sub>u</sub>=58ksi.

<sup>3</sup>ASTM F1554 Gr. 55 properties used: F<sub>y</sub>=55ksi, and F<sub>u</sub>=75ksi.

<sup>4</sup>ASD: Ω=2.0, LRFD: φ=0.75

<sup>5</sup>N/A – Not Applicable

TABLE 2 - STEEL THREADED ROD MINIMUM HOLE DEPTHS FOR SEISMIC DESIGN<sup>1,2,3</sup>

Rod Diameter (d)	Nominal Rod Diameter (d <sub>n</sub> )	Minimum Hole Depth	
		ASTM F1554, Grade 36	ASTM F1554, Grade 55
in.	in.	-	-
1/2	0.5	Shallow	Medium
5/8	0.625	Shallow	Medium
3/4	0.75	Shallow	Deep
7/8	0.875	Medium	Deep
1	1	Medium	-

For SI: 1 inch = 25.4 mm

<sup>1</sup>Required hole depth applies to both parallel and perpendicular to grain applications.

<sup>2</sup>See [Tables 3](#) and [4](#) for actual hole depths corresponding to shallow, medium, and deep.

<sup>3</sup>This table is applicable to seismic design in Seismic Design Categories C through F.

TABLE 3 - TENSION REFERENCE LOADS PARALLEL TO GRAIN<sup>2,6</sup>

Rod Diameter (d)	Shallow Hole Depth				Medium Hole Depth				Deep Hole Depth			
	Hole Depth <sup>1</sup> (h <sub>d</sub> )	R <sub>n</sub>			Hole Depth <sup>1</sup> (h <sub>d</sub> )	R <sub>n</sub>			Hole Depth <sup>1</sup> (h <sub>d</sub> )	R <sub>n</sub>		
		ASD Load <sup>3,4</sup> (C <sub>d</sub> =1.0)	ASD Load <sup>4</sup> (C <sub>d</sub> =1.6)	LRFD Load <sup>5</sup> (λ=1.0)		ASD Load <sup>3,4</sup> (C <sub>d</sub> =1.0)	ASD Load <sup>4</sup> (C <sub>d</sub> =1.6)	LRFD Load <sup>5</sup> (λ=1.0)		ASD Load <sup>3,4</sup> (C <sub>d</sub> =1.0)	ASD Load <sup>4</sup> (C <sub>d</sub> =1.6)	LRFD Load <sup>5</sup> (λ=1.0)
in.	in.	lb.	lb.	lb.	in.	lb.	lb.	lb.	in.	lb.	lb.	lb.
1/2	6-1/2	2,090	3,345	4,510	8	2,810	4,495	6,065	11-1/2	3,230	5,170	6,970
5/8	7-3/4	3,065	4,905	6,615	11-1/2	3,995	6,390	8,620	14	4,075	6,520	8,795
3/4	9	4,520	7,230	9,755	13-1/2	4,825	7,720	10,410	16-1/2	5,795	9,270	12,505
7/8	10-1/4	5,470	8,750	11,805	15-1/2	6,260	10,015	13,510	19	7,125	11,400	15,375
1	11-1/2	5,680	9,090	12,255	17-1/2	8,720	13,950	18,820	-	-	-	-

For SI: 1 inch = 25.4 mm, 1 ft-lb = 1.356 Nm.

<sup>1</sup>Hole Depth (h<sub>d</sub>) = Rod Embedment Depth + GARC and RECC Height

<sup>2</sup>Seismic Factor (φ<sub>seismic</sub>) = 1.0 (no reduction for seismic)

<sup>3</sup>Reference Load = mean normalized ultimate load / 5 (C<sub>d</sub>=1.0)

<sup>4</sup>Allowable loads are based on glulam members with a minimum tension parallel to grain of F<sub>t</sub>=1,100psi

<sup>5</sup>LRFD loads are based on glulam members with a minimum tension parallel to grain of F<sub>t</sub>=2,970psi

<sup>6</sup> All parallel to grain applications require reinforcing screws per [Figure 3](#) and [Figure 4](#). Geometrical dimensions must meet [Table 5](#) and [Figure 7](#).

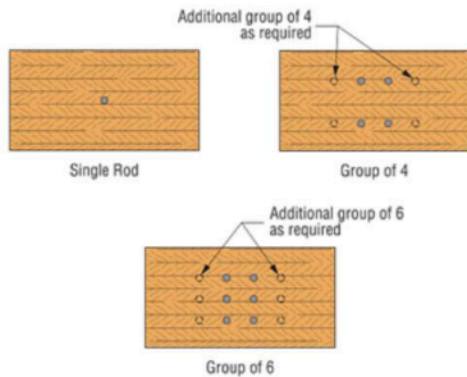

FIGURE 1 - GIR GROUP PARALLEL TO GRAIN CONFIGURATIONS

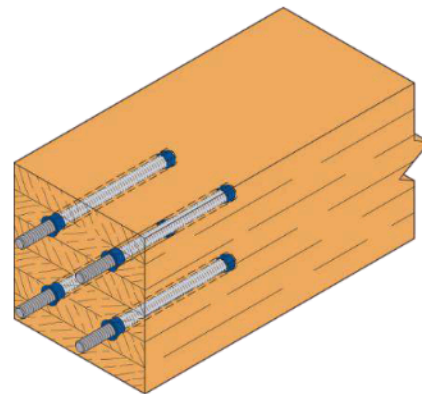

FIGURE 2 - GIR GROUP OF 4 PARALLEL TO GRAIN INSTALLATION

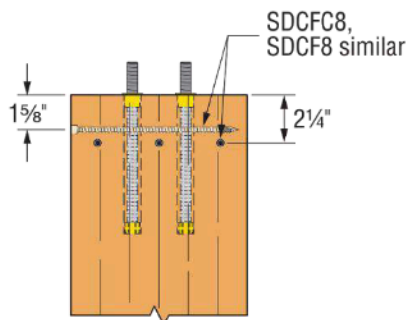

FIGURE 3 - PARALLEL TO GRAIN REQUIRED REINFORCEMENT - ELEVATION

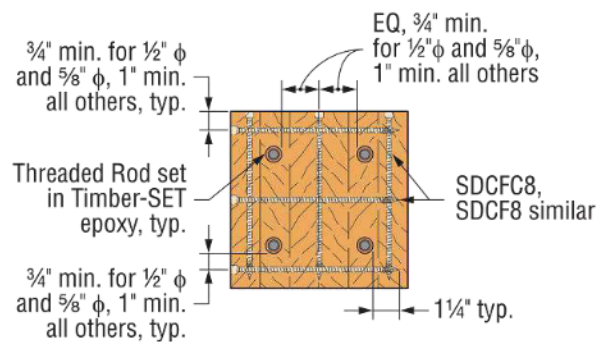

FIGURE 4 - PARALLEL TO GRAIN REQUIRED REINFORCEMENT - SECTION

Reinforcement Notes:

1. Fasteners: SDCFC8x/SDCFC8x = 0.315" O.D. (8mm) by length required Strong-Drive SDCF TIMBER-CF/ SDCF8 TIMBER-CFC screw.
2. Reinforcing screws are required on both sides (for single rods and groups) and between all rods (for groups).
3. Where 1-1/4" past edge of drilled hole (d<sub>c</sub>) cannot be met, 2 screws with 0.625" spacing (one from each side) may be used. Required edge distance of 3/4" for 1/2" Φ and 5/8" Φ and 1" minimum for all others to be maintained.

TABLE 4 - TENSION REFERENCE LOADS PERPENDICULAR TO GRAIN<sup>2,6</sup>

Rod Diameter (d)	Shallow Hole Depth				Medium Hole Depth				Deep Hole Depth			
	Hole Depth <sup>1</sup> (h <sub>d</sub> )	R <sub>n</sub>			Hole Depth <sup>1</sup> (h <sub>d</sub> )	R <sub>n</sub>			Hole Depth <sup>1</sup> (h <sub>d</sub> )	R <sub>n</sub>		
		ASD Load <sup>3,4</sup> (C <sub>d</sub> =1.0)	ASD Load <sup>4</sup> (C <sub>d</sub> =1.6)	LRFD Load <sup>5</sup> (λ=1.0)		ASD Load <sup>3,4</sup> (C <sub>d</sub> =1.0)	ASD Load <sup>4</sup> (C <sub>d</sub> =1.6)	LRFD Load <sup>5</sup> (λ=1.0)		ASD Load <sup>3,4</sup> (C <sub>d</sub> =1.0)	ASD Load <sup>4</sup> (C <sub>d</sub> =1.6)	LRFD Load <sup>5</sup> (λ=1.0)
in.	in.	lb.	lb.	lb.	in.	lb.	lb.	lb.	in.	lb.	lb.	lb.
1/2	6-1/2	2,805	4,490	6,055	8	2,970	4,750	6,410	9-1/2	3,230	5,170	6,970
5/8	7-3/4	3,825	6,120	8,255	11-1/2	4,375	7,000	9,440	14	6,050	9,680	13,055
3/4	9	4,560	7,295	9,840	13-1/2	6,480	10,370	13,985	16-1/2	8,040	12,865	17,350
7/8	10-1/4	5,470	8,750	11,805	15-1/2	8,030	12,850	17,330	19	9,610	15,375	20,740
1	11-1/2	7,235	11,575	15,615	17-1/2	9,620	15,390	20,760	-	-	-	-

For SI: 1 inch = 25.4 mm, 1 ft-lb = 1.356 Nm.

<sup>1</sup>Hole Depth (h<sub>d</sub>) = Rod Embedment Depth + GARC and RECC Height

<sup>2</sup>Seismic Factor (φ<sub>seismic</sub>) = 1.0 (no reduction for seismic)

<sup>3</sup>Reference Load = mean normalized ultimate load / 5 (C<sub>d</sub>=1.0)

<sup>4</sup>Allowable loads are based on minimum tension parallel to grain of F<sub>t</sub>=1,100psi

<sup>5</sup>LRFD loads are based on minimum tension parallel to grain of F<sub>t</sub>=2,970psi

<sup>6</sup>Geometrical dimensions must meet [Table 5](#) and [Figure 8](#).

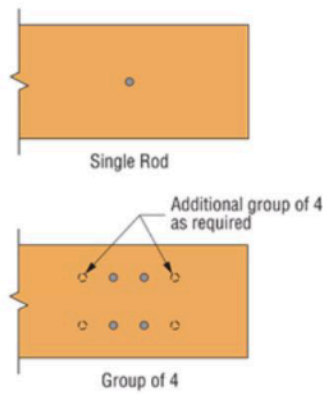

FIGURE 5 - GIR GROUP PERPENDICULAR TO GRAIN CONFIGURATIONS

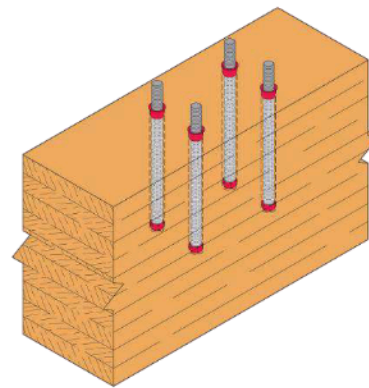
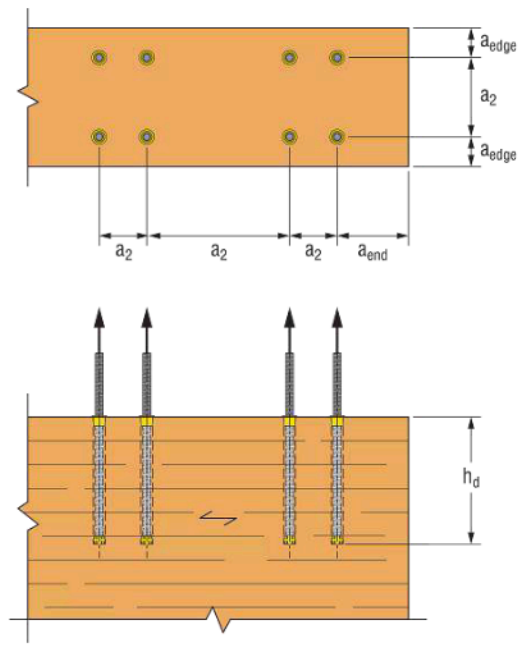
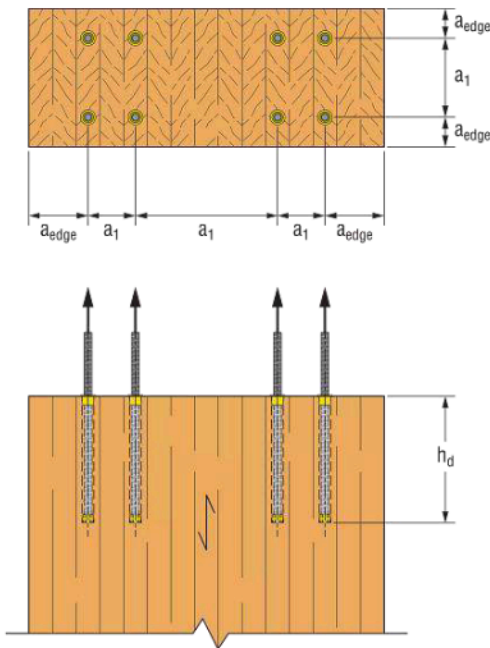

FIGURE 6 - GIR GROUP OF 4 PERPENDICULAR TO GRAIN INSTALLATION

TABLE 5 - MINIMUM GEOMETRIC DIMENSIONS

Rod Diameter (d)	Hole Diameter (d <sub>o</sub> )	Rod Spacing (a <sub>1</sub> )	Rod Spacing (a <sub>2</sub> )	Rod Edge Distance (a <sub>edge</sub> )	Rod End Distance (a <sub>end</sub> )
in.	in.	in.	in.	in.	in.
1/2	3/4	2-1/4	2-1/4	1-7/8	5-1/2
5/8	7/8	2-7/8	2-7/8	1-15/16	6-7/8
3/4	1	3-3/8	3-3/8	2-1/2	8-1/4
7/8	1-1/8	3-1/2	3-5/8	2-9/16	9-5/8
1	1-1/4	3-1/2	3-3/4	2-5/8	11

For SI: 1 inch = 25.4 mm



Note: Reinforcing screws not shown for clarity

FIGURE 7 - PARALLEL TO GRAIN GEOMETRIC DIMENSIONS

FIGURE 8 - PERPENDICULAR TO GRAIN GEOMETRIC DIMENSIONS

<p><b>1</b> <b>Hole Preparation</b> <i>Horizontal, &amp; Vertical Applications</i></p> <div style="display: flex; justify-content: space-around;"> <div style="width: 45%;">  <p><b>1 Drill.</b> For 1/2" through 1" diameter threaded rod anchors, hole diameter = anchor diameter + 1/4". Drilled holes are limited to a maximum misalignment of 3 degrees from the intended plane of installation.</p> </div> <div style="width: 45%;">  <p><b>2 Blow (2 seconds).</b> Compressed air nozzle must reach the bottom of the hole.</p> </div> </div> <div style="display: flex; justify-content: space-around; margin-top: 10px;"> <div style="width: 45%;">  <p><b>3 Brush</b> Clean with appropriate size ETB model nylon brush for a minimum of 2 cycles. Brush must reach the bottom of the hole. Brush should provide resistance to insertion. If no resistance is felt, the brush is worn and must be replaced.</p> </div> <div style="width: 45%;">  <p><b>4 Blow (2 seconds).</b> Compressed air nozzle must reach the bottom of the hole.</p> </div> </div> <p><b>Note: Repeat steps 2 through 4. Then proceed to the next step.</b></p>	<p><b>2</b> <b>Cartridge Preparation</b> <i>All Applications</i></p> <div style="display: flex; justify-content: space-around;"> <div style="width: 45%;">  <p><b>5. Check &amp; Open</b> Check expiration date on product cartridge. Do not use expired product. Hold cartridge upright, unscrew cap nut and remove plugs.</p> </div> <div style="width: 45%;">  <p><b>6. Attach Nozzle</b> Attach AMN19Q mixing nozzle (included).</p> </div> </div> <div style="display: flex; justify-content: space-around; margin-top: 10px;"> <div style="width: 45%;">  <p><b>7. Install Cartridge</b> Insert cartridge into dispensing tool. NOTE – When using a pneumatic dispensing tool, regulate air pressure to 80-100 psi.</p> </div> <div style="width: 45%;">  <p><b>8. Adhesive Mixing</b> Dispense a bead of Timber-SET off to side to assure proper mixing before dispensing into hole(s). When properly mixed, Timber-SET adhesive will be a uniform gray color.</p> </div> </div>
<p><b>3</b> <b>Filling the Hole</b> <i>Horizontal, &amp; Vertical Anchorage with Piston Plug System</i></p>	
 <p><b>9. Piston Plug and Tubing</b> Attach appropriate size piston plug (PP) and tubing (PPFT25) to the nozzle. Cut tubing to the length needed for the application, mark tubing as noted below and attach other end of tubing to the mixing nozzle. Requires Piston Plug Adhesive Delivery System: Refer to instructions provided with piston plugs for injecting adhesive.</p>	<div style="display: flex; justify-content: space-around;"> <div style="width: 45%;">  <p><b>11a. Adhesive Retaining Cap (GARC)</b> Slide the GARC onto the rod.</p> </div> <div style="width: 45%;">  <p><b>11b. Rod End Centering Cap (RECC)</b> Screw the RECC onto the end of the rod.</p> </div> </div> <div style="display: flex; justify-content: space-around; margin-top: 10px;"> <div style="width: 45%;">  <p><b>11c. Install Threaded Rod</b> Insert rod assembly into the hole without twisting until the anchor bottoms out. Verify hole is completely filled with epoxy.</p> </div> <div style="width: 45%;">  <p><b>11d. Final Assembly</b> Do not disturb until fully cured.</p> </div> </div>
<div style="display: flex; justify-content: space-around;"> <div style="width: 45%;">  <p><b>10a. Dispense Adhesive</b> Insert the piston plug to the back of the drilled hole and dispense adhesive</p> </div> <div style="width: 45%;">  <p><b>10b. Dispense Adhesive</b> Fill the hole 1/2 to 2/3 full</p> <p><b>Note:</b> As adhesive is dispensed into the drilled hole, the piston plug will slowly displace out of the hole due to back pressure, preventing air gaps.</p> </div> </div>	

FIGURE 9 - INSTALLATION DETAILS

TABLE 6 - INSTALLATION DETAILS FOR THREADED RODS

Anchor Diameter (in)	Drill Bit Diameter <sup>2</sup> (in)	Brush Part Number	Nozzle Part Number <sup>3</sup>	Dispensing Tool Part Number	Adhesive Retaining Cap Part Number	End Rod Centering Cap Part Number	Adhesive Tubing Part Number	Adhesive Piston Plug Part Number
1/2	3/4	ETB6	AMN19Q <sup>1</sup>	ADT30S, ADTA30P, ADTA30CKT	GARC4-RP25	RECC4-RP25	PPFT25	PP75-RP10
5/8	7/8	ETB8			GARC5-RP25	RECC5-RP25		PP87-RP10
3/4	1	ETB10			GARC6-RP25	RECC6-RP25		PP100-RP10
7/8	1-1/8	ETB10			GARC7-RP25	RECC7-RP25		PP112-RP10
1	1-1/4	ETB12			GARC8-RP25	RECC8-RP25		PP125-RP10

<sup>1</sup>One AMN19Q mixing nozzle is supplied with each cartridge.

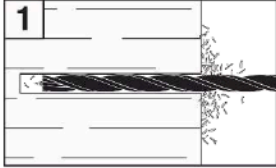
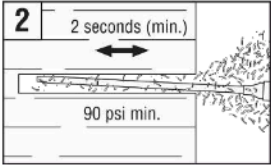
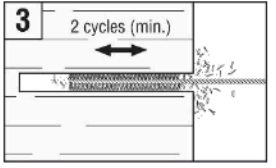
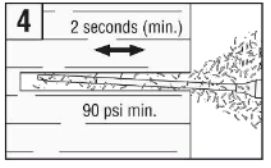
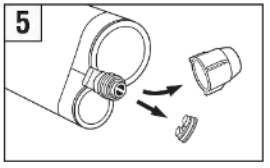
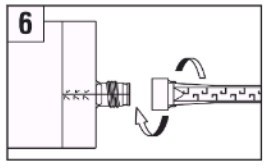
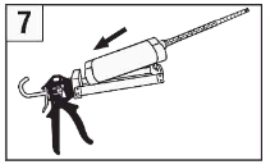
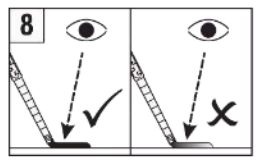
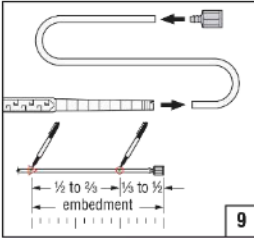
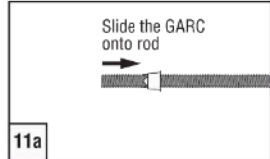
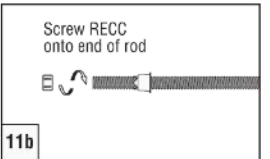
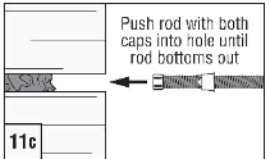
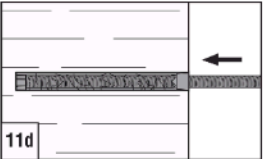
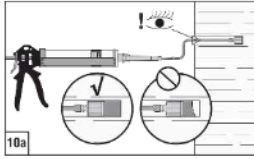
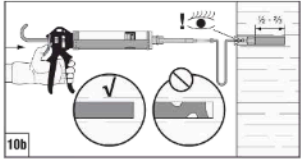
<sup>2</sup>Use Wood Owl Deep Ultra Smooth Tri-Cut Auger Drill Bits or similar.

<sup>3</sup>Use only Simpson Strong-Tie mixing nozzles in accordance with Simpson Strong-Tie instructions.

TABLE 7 - CURE SCHEDULE<sup>2,3,4</sup>

Wood Temperature <sup>1</sup>		Gel Time (min.)	Cure Time
(°F)	(°C)		
50	10	120	14 days
60	16	45	7 days
70	21	33	24 hrs.
90	32	16	24 hrs.

For SI: °C = 5/9 (°F – 32)

<sup>1</sup>The temperatures listed above refer to the base-material temperature, not ambient air temperature.

<sup>2</sup>For Installation of threaded rods in timber where temperature is between 50°F and 70°F (10°C to 21°C), the adhesive must be conditioned to a minimum temperature of 70°F (21°C).

<sup>3</sup>The anchors may be adjusted during the gel time following installation.

<sup>4</sup>Anchors must not be disturbed between gel time and curing time. The anchors may be loaded after the full curing time has elapsed.

TABLE 8 - STORAGE INFORMATION

Storage Temperature		Shelf Life (months)
(°F)	(°C)	
45 to 90	7 to 32	24

**DIVISION: 06 00 00—WOOD, PLASTICS AND COMPOSITES**  
**Section: 06 05 23—Wood, Plastic, and Composite Fastenings**

**REPORT HOLDER:**

**SIMPSON STRONG-TIE COMPANY INC.**

**EVALUATION SUBJECT:**

**SIMPSON STRONG-TIE® Timber-SET STRUCTURAL EPOXY ANCHORING ADHESIVE FOR TIMBER ROD CONNECTIONS**

**1.0 REPORT PURPOSE AND SCOPE**

**Purpose:**

The purpose of this evaluation report supplement is to indicate that the Simpson Strong-Tie® Timber-SET Structural Epoxy Anchoring system for timber rod connections, described in ICC-ES evaluation report [ESR-5283](#), has also been evaluated for compliance with the codes noted below as adopted by the Los Angeles Department of Building and Safety (LADBS).

**Applicable code editions:**

- 2026 City of Los Angeles Building Code ([LABC](#))
- 2026 City of Los Angeles Residential Code ([LARC](#))

**2.0 CONCLUSIONS**

The Simpson Strong-Tie® Timber-SET Structural Epoxy Anchoring system for timber rod connections, described in Sections 2.0 through 7.0 of the evaluation report [ESR-5283](#), comply with the LABC Chapter 23 and the LARC, and are subject to the conditions of use described in this supplement.

**3.0 CONDITIONS OF USE**

The Simpson Strong-Tie® Timber-SET Structural Epoxy Anchoring system for timber rod connections described in this evaluation report supplement must comply with all of the following conditions:

- All applicable sections in the evaluation report [ESR-5283](#).
- The design, installation, conditions of use and identification of the Simpson Strong-Tie® Timber-SET Structural Epoxy Anchoring system for timber rod connections are in accordance with the 2024 *International Building Code*® (IBC) provisions noted in the evaluation report [ESR-5283](#).
- The design, installation and inspection are in accordance with additional requirements of LABC Chapters 16, 17 and 23, as applicable.
- Under the LARC, an engineered design in accordance with LARC Section R301.1.3 must be submitted.
- The Simpson Strong-Tie Timber-Set Structural Epoxy Anchoring system must be produced in the shop of an approved City of Los Angeles Fabricator, in accordance with the 2026 LABC Section 202 definition for “Fabricated Item” and 2026 LABC Division C Section 96.200 “Fabricator Approvals.”

This supplement expires concurrently with the evaluation report, issued April 2026.

DIVISION: 06 00 00—WOOD, PLASTICS AND COMPOSITES  
Section: 06 05 23—Wood, Plastic, and Composite Fastenings

**REPORT HOLDER:**

**SIMPSON STRONG-TIE COMPANY INC.**

**EVALUATION SUBJECT:**

**SIMPSON STRONG-TIE® Timber-SET STRUCTURAL EPOXY ANCHORING ADHESIVE FOR TIMBER ROD CONNECTIONS**

**1.0 REPORT PURPOSE AND SCOPE****Purpose:**

The purpose of this evaluation report supplement is to indicate that Simpson Strong-Tie® Strong-Drive Timber-SET Structural Epoxy Anchoring system for timber rod connections, described in ICC-ES evaluation report [ESR-5283](#), have also been evaluated for compliance with the codes noted below.

**Applicable code editions:**

- 2023 *Florida Building Code—Building*
- 2023 *Florida Building Code—Residential*

**2.0 CONCLUSIONS**

The Simpson Strong-Tie® Timber-SET Structural Epoxy Anchoring system for timber rod connections, described in Sections 2.0 through 7.0 of ICC-ES evaluation report [ESR-5283](#), complies with the *Florida Building Code—Building* and *Florida Building Code—Residential*. The design requirements must be determined in accordance with the *Florida Building Code—Building* or the *Florida Building Code—Residential*, as applicable. The installation requirements noted in ICC-ES evaluation report [ESR-5283](#) for the 2021 *International Building Code*® meet the requirements of the *Florida Building Code—Building* or the *Florida Building Code—Residential*, as applicable.

Use of the Simpson Strong-Tie® Timber-SET Structural Epoxy Anchoring system for timber rod connections have also been found to be in compliance with the High-Velocity Hurricane Zone provisions of the *Florida Building Code—Building* and the *Florida Building Code—Residential* with the following condition:

- a. For anchorage to wood members, the connection subject to uplift must be designed for no less than 700 pounds (3114 N) in accordance with item 3 of Section 2321.7 of the *Florida Building Code—Building*.

For products falling under Florida Rule 61G20-3, verification that the report holder's quality assurance program is audited by a quality assurance entity approved by the Florida Building Commission for the type of inspections being conducted is the responsibility of an approved validation entity (or the code official when the report holder does not possess an approval by the Commission). Florida Rule 61G20-3 is applicable to products and/or systems which comprise the building envelope and structural frame for compliance with the structural requirements of the Florida Building Code.

This supplement expires concurrently with the evaluation report, issued April 2026.