

LUS/HUS/HHUS/HGUS

Double-Shear Face-Mount Joist Hangers

Solid Sawn Joist Hangers



This product is preferable to similar connectors because of (a) easier installation, (b) higher loads, (c) lower installed cost, or a combination of these features.

All hangers in this series have double-shear nailing. This innovation distributes the load through two points on each joist nail for greater strength. It also allows the use of fewer nails, faster installation and the use of standard nails for all connections. (Do not bend or remove tabs.)

Material: See tables, pp. 104–114

Finish: Galvanized. Some products available in stainless steel or ZMAX® coating; see Corrosion Information, pp. 12–15.

Installation:

- Use all specified fasteners; see General Notes.
- Nails must be driven at an angle through the joist or truss into the header to achieve the table loads.
- Not designed for welded or nailer applications.
- With 3x carrying members: when 0.162" x 3½" nails are specified, use 0.162" x 2½" nails into the header and 0.162" x 3½" nails into the joist with no load reduction. When 0.148" x 3" nails are specified, use 0.148" x 2½" nails into the header and 0.148" x 3" nails into the joist with no load reduction.
- With 2x carrying members: when 0.162" x 3½" nails are specified, use 0.148" x 1½" nails into the header and 0.148" x 3" nails into the joist and reduce the load to 0.64 of the table values. When 0.148" x 3" nails are specified, use 0.148" x 1½" nails into the header and 0.148" x 3" nails into the joist and reduce the load to 0.77 of the table values. See p. 22 for specific Load Adjustment Factors.

Allowable Loads:

- See table on pp. 104–114 for loads.

Options:

- LUS/HUS hangers cannot be modified.
- See next page for HHUS/HGUS modifications.

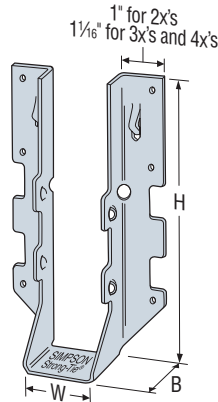

LUS28

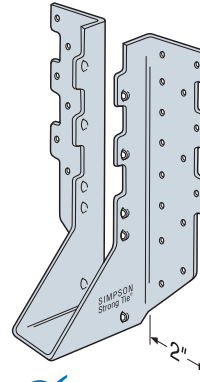

HUS210
(HUS26 and HUS28 similar)

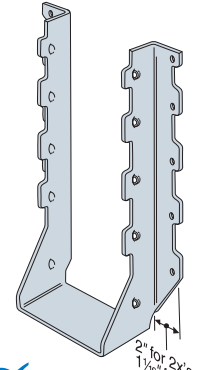

HUS412

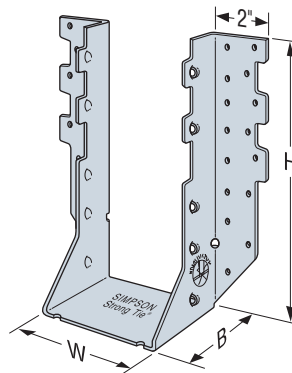

HHUS410

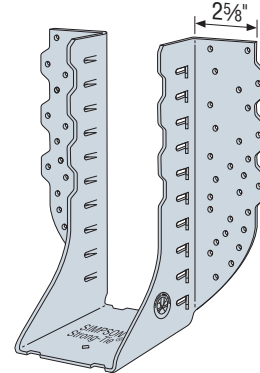

HGUS3.25/12

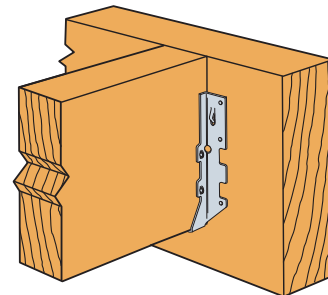

Typical LUS28 Installation
use 0.148" x 3" nail or 0.148" x 3¼" nail

Double-Shear Nailing

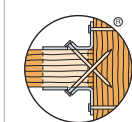

Double-Shear Nailing Top View

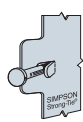

Double-Shear Nailing Side View — Do not bend tab

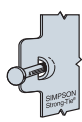

Dome Double-Shear Nailing Side View (Available on some models)

LUS/HUS/HHUS/HGUS

Double-Shear Face-Mount Joist Hangers (cont.)

HHUS/HGUS

HHUS — Sloped and/or Skewed Seat

- HHUS hangers can be skewed to a maximum of 45° and/or sloped to a maximum of 45°
- For skew only, maximum allowable download is 0.85 of the table load
- For sloped only or sloped and skewed hangers, the maximum allowable download is 0.65 of the table load
- Uplift loads for sloped/skewed conditions are 0.72 of the table load, not to exceed 2,475 lb.
- The joist must be bevel-cut to allow for double-shear nailing

HGUS — Skewed Seat

- HGUS hangers can be skewed only to a maximum of 45°. Allowable loads are:

HGUS Seat Width	Carried Member End Condition			
	Square Cut		Bevel Cut	
	Uplift	Download	Uplift	Download
$W < 2"$	0.46	0.62	0.46	0.72
$2" < W < 6"$	0.41	0.46	0.41	0.85
$6" < W < 6.75"$		0.40		
$6.75" < W < 7.25"$	Not allowed	Not allowed		

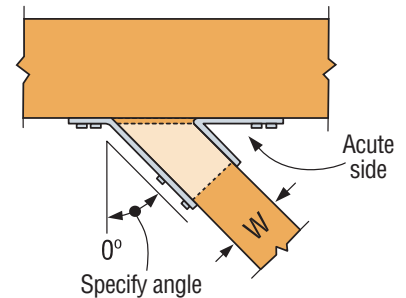

Top View HHUS Hanger Skewed Right
(joist must be bevel cut)
 All joist nails installed on the outside angle (*non-acute side*).

HUCQ

Heavy-Duty Face-Mount Joist Hanger

The HUCQ series are heavy-duty joist hangers that incorporate Strong-Drive® SDS Heavy-Duty Connector screws. Designed and tested for installation at the end of a beam or on a post, they provide a strong connection with fewer fasteners than nailed hangers. See pp. 145–152 for structural composite lumber hangers.

Features:

- Fire-resistant F (flame) and T (temperature) rated in Intertek Design No. SST/WPCF 120-01.



Material: 14 gauge

Finish: Galvanized. Most models available in stainless steel or ZMAX® coating.

Installation:

- Use all specified fasteners; see General Notes.
- Install ¼" x 2½" Strong-Drive SDS Heavy-Duty Connector screws, which are provided, in all round holes. (Lag screws will not achieve the same load.)
- HUCQ hangers can be welded to a steel member. Allowable loads are the lesser of the values in the hanger tables on pp. 104–114 or the weld capacity — refer to technical bulletin T-C-HUHUC-W at strongtie.com.

Allowable Loads:

- See table on pp. 104–114 for loads.

Options:

- These hangers cannot be modified.

Codes: See p. 11 for Code Reference Key Chart

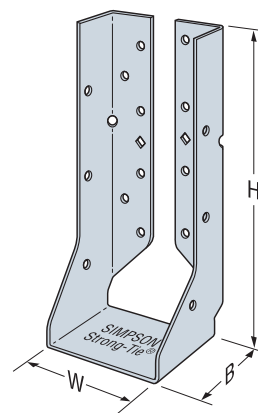

HUCQ410-SDS

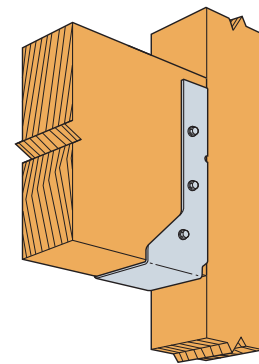

Typical HUCQ Installation on a Post

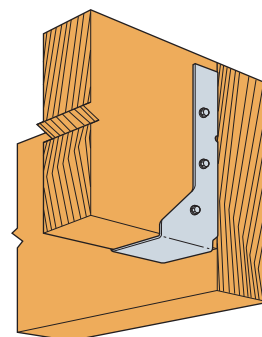

Typical HUCQ Installation on a Beam

HUS/HHUS/HGUS

Double-Shear Face-Mount Hangers



This product is preferable to similar connectors because of (a) easier installation, (b) higher loads, (c) lower installed cost, or a combination of these features.

See hanger tables on pp. 145–152.

These hangers are designed for applications where higher loads are needed (also see HUC and HUCQ).

All hangers in this series have double-shear nailing. This innovation distributes the load through two points on each joist nail for greater strength. It also allows the use of fewer nails, faster installation and the use of common nails for all connections. (Do not bend or remove tabs.)

Material: HHUS — 14 gauge; HGUS — 12 gauge; HUS 2x and 1¼ sizes — 16 gauge; HUS — 14 gauge

Finish: Galvanized. Some products available in stainless steel or ZMAX®. See Corrosion Information, pp. 12–15.

Installation:

- Use all specified fasteners; see General Notes.
- Do not use double-shear hangers with I-joists.
- Nails must be driven at an angle through the joist or truss into the header to achieve the table loads.
- Not designed for welded or nailer applications.
- See p. 22 for alternate fastener sizes and load adjustments.

Options:

- HUS cannot be modified
- Other sizes available; contact Simpson Strong-Tie for details

HHUS — Sloped and/or Skewed Seat

- HHUS hangers can be skewed to a maximum of 45° and/or sloped to a maximum of 45°
- For skew only, maximum allowable download is 0.85 of the table load
- For sloped only or sloped and skewed hangers, the maximum allowable download is 0.65 of the table load
- Uplift loads for sloped/skewed conditions are 0.72 of the table load, not to exceed 2,475 lb.
- The joist must be bevel-cut to allow for double shear nailing

HGUS — Skewed Seat

- HGUS hangers can be skewed only to a maximum of 45°. Allowable loads are:

HGUS Seat Width	Carried Member End Condition			
	Square Cut		Bevel Cut	
	Uplift	Download	Uplift	Download
W < 2"	0.46	0.62	0.46	0.72
2" < W < 6"	0.41	0.46	0.41	0.85
6" < W < 6.75"		0.40		
6.75" < W < 7.25"	Not allowed	Not allowed		

Codes: See p. 11 for Code Reference Key Chart

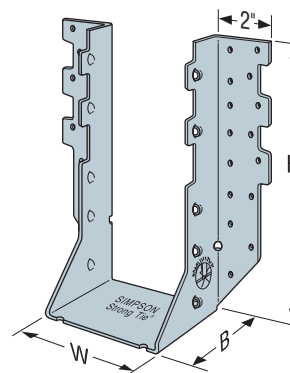

✓ HHUS410

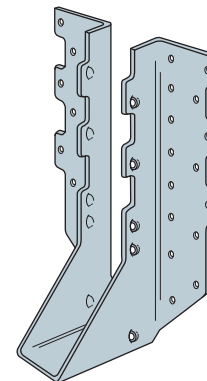

✓ HUS181-10

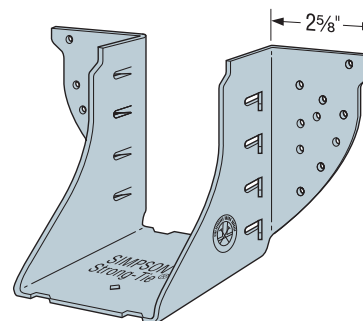

✓ HGUS46

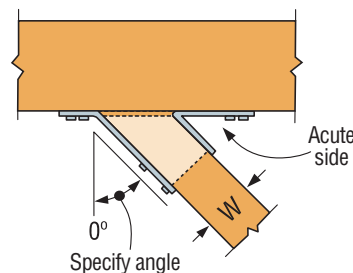

Top View HHUS Hanger Skewed Right
(joist must be bevel cut)

LUS/MUS/HUS/HHUS/HGUS

Face-Mount Joist Hangers



This product is preferable to similar connectors because of a) easier installation, b) higher loads, c) lower installed cost, or a combination of these features.

The double-shear hanger series, ranging from the light-capacity LUS hangers to the highest-capacity HGUS hangers, feature innovative double-shear nailing that distributes the load through two points on each joist nail for greater strength. This allows for fewer nails, faster installation and the use of all common nails for the same connection.

For medium-load truss applications, the MUS offers a lower-cost alternative and easier installation than the HUS or THA hangers, while providing greater load capacity and bearing than the LUS.

Material: See tables on pp. 200–201

Finish: Galvanized. Some products available in stainless steel or ZMAX® coating. See Corrosion Information, pp. 12–15.

Installation:

- Use all specified fasteners; see General Notes.
- Nails must be driven at an angle through the joist or truss into the header to achieve the table loads.
- Not designed for welded or nailer applications.

Options:

- LUS and MUS hangers cannot be modified
- Concealed flanges are not available for HGUS and HHUS
- Other sizes available; consult your Simpson Strong-Tie representative

Codes: See p. 11 for Code Reference Key Chart

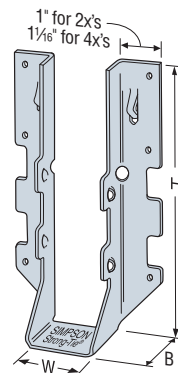

LUS28

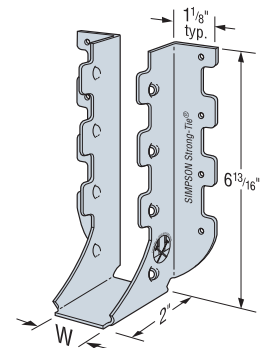

MUS28

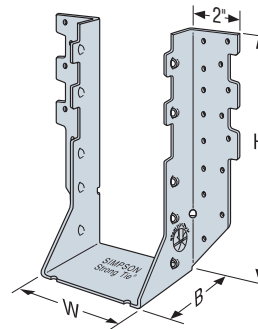

HHUS210-2

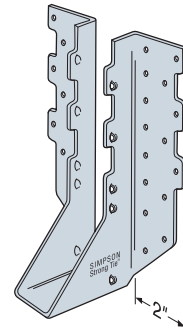

HUS210
(HUS26, HUS28, and HHUS similar)

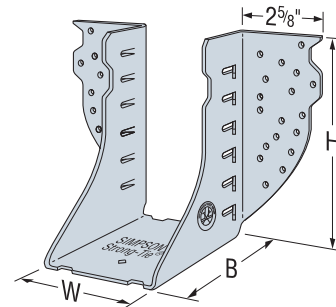

HGUS28-2

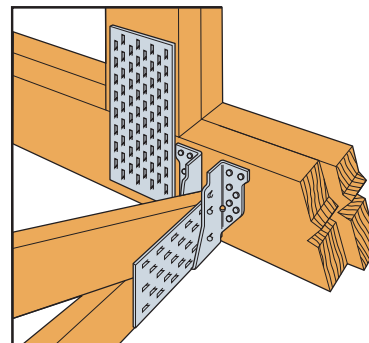
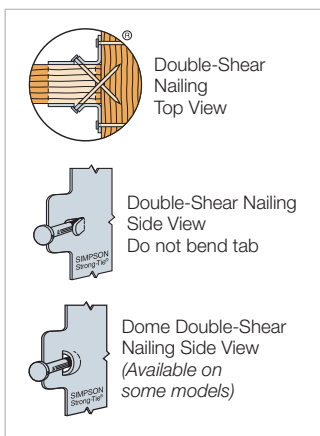

Typical HUS26 Installation with Reduced Heel Height
(multiple member fastening by designer)

LUS/MUS/HUS/HHUS/HGUS

Face-Mount Joist Hangers (cont.)

Plated Truss Connectors

Model No.	Min. Heel Height	Ga.	Dimensions (in.)			Fasteners	
			W	H	B	Carrying Member	Carried Member
Single 2x Sizes							
LUS24	2 ⁵ / ₁₆	18	1 ¹ / ₁₆	3 ¹ / ₈	1 ³ / ₄	(4) 0.148 x 3	(2) 0.148 x 3
SS LUS26	4 ¹ / ₄	18	1 ¹ / ₁₆	4 ³ / ₄	1 ³ / ₄	(4) 0.148 x 3	(4) 0.148 x 3
MUS26	4 ¹ / ₁₆	18	1 ¹ / ₁₆	5 ³ / ₁₆	2	(6) 0.148 x 3	(6) 0.148 x 3
HUS26	4 ⁵ / ₁₆	16	1 ¹ / ₈	5 ³ / ₈	3	(14) 0.162 x 3 ¹ / ₂	(6) 0.162 x 3 ¹ / ₂
HGUS26	4 ⁹ / ₁₆	12	1 ¹ / ₈	5 ³ / ₈	5	(20) 0.162 x 3 ¹ / ₂	(8) 0.162 x 3 ¹ / ₂
SS LUS28	4 ³ / ₁₆	18	1 ¹ / ₁₆	6 ⁵ / ₈	1 ³ / ₄	(6) 0.148 x 3	(4) 0.148 x 3
MUS28	6 ⁵ / ₁₆	18	1 ¹ / ₁₆	6 ¹³ / ₁₆	2	(8) 0.148 x 3	(8) 0.148 x 3
HUS28	6 ¹ / ₂	16	1 ¹ / ₈	7	3	(22) 0.162 x 3 ¹ / ₂	(8) 0.162 x 3 ¹ / ₂
HGUS28	6 ⁹ / ₁₆	12	1 ¹ / ₈	7 ¹ / ₈	5	(36) 0.162 x 3 ¹ / ₂	(12) 0.162 x 3 ¹ / ₂
SS LUS210	4 ¹ / ₄	18	1 ¹ / ₁₆	7 ¹³ / ₁₆	1 ³ / ₄	(8) 0.148 x 3	(4) 0.148 x 3
HUS210	8 ³ / ₁₆	16	1 ¹ / ₈	9	3	(30) 0.162 x 3 ¹ / ₂	(10) 0.162 x 3 ¹ / ₂
HGUS210	8 ⁹ / ₁₆	12	1 ¹ / ₈	9 ¹ / ₈	5	(46) 0.162 x 3 ¹ / ₂	(16) 0.162 x 3 ¹ / ₂

1. See table below for allowable loads.

These products are available with additional corrosion protection. For more information, see p. 14.

SS For stainless-steel fasteners, see p. 21.

SD Many of these products are approved for installation with Strong-Drive® SD Connector screws. See pp. 348–352 for more information.

Model No.	DF Allowable Loads					SP Allowable Loads					SPF/HF Allowable Loads					Code Ref.
	Uplift (160)	Floor (100)	Snow (115)	Roof (125)	Wind (160)	Uplift (160)	Floor (100)	Snow (115)	Roof (125)	Wind (160)	Uplift (160)	Floor (100)	Snow (115)	Roof (125)	Wind (160)	
Single 2x Sizes																
LUS24	435	670	765	820	1,045	435	725	825	890	1,120	360	495	565	605	770	IBC, FL, LA
SS LUS26	1,165	865	990	1,070	1,355	1,165	935	1,070	1,150	1,475	865	635	725	785	1,000	
MUS26	930	1,295	1,480	1,560	1,560	930	1,405	1,560	1,560	1,560	810	955	1,090	1,180	1,350	
HUS26	1,320	2,735	3,095	3,235	3,235	1,320	2,960	3,280	3,280	3,280	1,150	2,350	2,660	2,780	2,780	
HGUS26	1,040	4,355	4,875	5,230	5,390	1,045	4,725	5,295	5,390	5,390	1,005	3,755	4,205	4,495	5,390	
SS LUS28	1,165	1,100	1,260	1,350	1,725	1,165	1,195	1,360	1,465	1,730	865	810	925	1,000	1,270	
MUS28	1,320	1,730	1,975	2,125	2,255	1,320	1,875	2,135	2,255	2,255	1,150	1,270	1,455	1,575	1,955	
HUS28	1,760	4,095	4,095	4,095	4,095	1,760	4,095	4,095	4,095	4,095	1,480	3,520	3,520	3,520	3,520	
HGUS28	1,650	7,275	7,275	7,275	7,275	1,650	7,275	7,275	7,275	7,275	1,485	6,010	6,255	6,255	6,255	
SS LUS210	1,165	1,335	1,530	1,640	2,090	1,165	1,450	1,655	1,775	2,270	865	985	1,120	1,215	1,500	
HUS210	2,635	5,450	5,795	5,830	5,830	2,635	5,395	5,780	5,830	5,830	2,220	4,685	4,985	5,015	5,015	
HGUS210	2,090	9,100	9,100	9,100	9,100	2,090	9,100	9,100	9,100	9,100	1,545	6,340	6,730	6,730	6,730	

1. For dimensions and fastener information, see table above. See table footnotes on p. 201.

HHUS/HGUS

See Hanger Options information on pp. 97–99.

HHUS — Sloped and/or Skewed Seat

- HHUS hangers can be skewed to a maximum of 45° and/or sloped to a maximum of 45°
- For skew only, maximum allowable download is 0.85 of the table load
- For sloped only, or sloped and skewed hangers, the maximum allowable download is 0.65 of the table load
- Uplift loads for sloped/skewed conditions are 0.72 of the table load, not to exceed 2,475 lb.
- The joist must be bevel-cut to allow for double shear nailing

HGUS — Skewed Seat

- HGUS hangers can be skewed only to a maximum of 45°. Allowable loads are:

HGUS Seat Width	Carried Member End Condition			
	Square Cut		Bevel Cut	
	Uplift	Download	Uplift	Download
W < 2"	0.46	0.62	0.46	0.72
2" < W < 6"	0.41	0.46	0.41	0.85
6" < W < 6.75"		0.40		
6.75" < W < 7.25"	Not allowed	Not allowed		

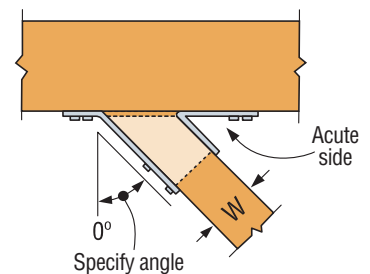

Top View HHUS Hanger Skewed Right
(joist must be bevel cut)
All joist nails installed on the outside angle (non-acute side).

LUS/MUS/HUS/HHUS/HGUS

These products are available with additional corrosion protection. For more information, see p. 14.

SS For stainless-steel fasteners, see p. 21.

SD Many of these products are approved for installation with Strong-Drive® SD Connector screws. See pp. 348–352 for more information.

Model No.	Min. Heel Height	Ga.	Dimensions (in.)			Fasteners (in.)		DF/SP Allowable Loads					SPF/HF Allowable Loads					Code Ref.
			W	H	B	Carrying Member	Carried Member	Uplift (160)	Floor (100)	Snow (115)	Roof (125)	Wind (160)	Uplift (160)	Floor (100)	Snow (115)	Roof (125)	Wind (160)	
Double 2x Sizes																		
LUS24-2	2¼	18	3½	3½	2	(4) 0.162 x 3½	(2) 0.162 x 3½	410	800	905	980	1,245	355	690	780	845	1,070	IBC, FL, LA
SS LUS26-2	4⅞	18	3½	4⅞	2	(4) 0.162 x 3½	(4) 0.162 x 3½	1,060	1,030	1,170	1,265	1,595	910	885	1,005	1,090	1,370	
HHUS26-2	4⅞	14	3⅝	5⅞	3	(14) 0.162 x 3½	(6) 0.162 x 3½	1,320	2,830	3,190	3,415	4,250	1,135	2,435	2,745	2,935	3,655	
HGUS26-2	4⅞	12	3⅝	5⅞	4	(20) 0.162 x 3½	(8) 0.162 x 3½	2,155	4,355	4,875	5,230	5,575	2,155	3,755	4,875	5,230	5,255	
SS LUS28-2	4⅞	18	3½	7	2	(6) 0.162 x 3½	(4) 0.162 x 3½	1,060	1,315	1,490	1,610	2,030	910	1,130	1,280	1,385	1,745	
HHUS28-2	6⅞	14	3⅝	7¼	3	(22) 0.162 x 3½	(8) 0.162 x 3½	1,760	4,265	4,810	5,155	5,980	1,515	3,670	4,135	4,435	5,145	
HGUS28-2	6⅞	12	3⅝	7⅜	4	(36) 0.162 x 3½	(12) 0.162 x 3½	3,235	7,460	7,460	7,460	7,460	2,780	6,415	6,415	6,415	6,415	
SS LUS210-2	6⅞	18	3½	9	2	(8) 0.162 x 3½	(6) 0.162 x 3½	1,445	1,830	2,075	2,245	2,830	1,245	1,575	1,785	1,930	2,435	
HHUS210-2	8⅞	14	3⅝	9⅞	3	(30) 0.162 x 3½	(10) 0.162 x 3½	3,550	5,705	6,435	6,485	6,485	3,335	4,905	5,340	5,060	5,190	
HGUS210-2	8⅞	12	3⅝	9⅞	4	(46) 0.162 x 3½	(16) 0.162 x 3½	4,095	9,100	9,100	9,100	9,100	3,520	7,460	7,825	7,825	7,825	
Triple 2x Sizes																		
HGUS26-3	4⅞	12	4⅞	5½	4	(20) 0.162 x 3½	(8) 0.162 x 3½	2,155	4,355	4,875	5,230	5,575	2,155	3,755	4,875	5,230	5,255	IBC, FL, LA
HGUS28-3	6⅞	12	4⅞	7¼	4	(36) 0.162 x 3½	(12) 0.162 x 3½	3,235	7,460	7,460	7,460	7,460	2,780	6,415	6,415	6,415	6,415	IBC, FL, LA
HHUS210-3	8⅞	14	4⅞	8⅞	3	(30) 0.162 x 3½	(10) 0.162 x 3½	3,405	5,640	6,380	6,485	6,485	2,930	4,850	5,485	5,575	5,575	FL
HGUS210-3	8⅞	12	4⅞	9¼	4	(46) 0.162 x 3½	(16) 0.162 x 3½	4,095	9,100	9,100	9,100	9,100	3,520	7,825	7,825	7,825	7,825	IBC, FL, LA
HGUS212-3	10⅞	12	4⅞	10¾	4	(56) 0.162 x 3½	(20) 0.162 x 3½	5,205	11,915	13,330	14,290	14,350	4,730	10,280	12,420	12,420	12,420	IBC, FL, LA
HGUS214-3	12⅞	12	4⅞	12¾	4	(66) 0.162 x 3½	(22) 0.162 x 3½	5,360	13,860	14,350	14,350	14,350	4,915	11,960	12,420	12,420	12,420	IBC, FL, LA
Quadruple 2x Sizes																		
HGUS26-4	5½	12	6⅞	5⅞	4	(20) 0.162 x 3½	(8) 0.162 x 3½	2,155	4,355	4,875	5,230	5,575	2,155	3,755	4,875	5,230	5,255	IBC, FL, LA
HGUS28-4	7¼	12	6⅞	7⅞	4	(36) 0.162 x 3½	(12) 0.162 x 3½	3,235	7,460	7,460	7,460	7,460	2,780	6,415	6,415	6,415	6,415	IBC, FL, LA
HHUS210-4	8⅞	14	6⅞	8⅞	3	(30) 0.162 x 3½	(10) 0.162 x 3½	3,405	5,640	6,380	6,485	6,485	2,930	4,850	5,485	5,575	5,575	FL
HGUS210-4	9¼	12	6⅞	9⅞	4	(46) 0.162 x 3½	(16) 0.162 x 3½	4,095	9,100	9,100	9,100	9,100	3,520	7,825	7,825	7,825	7,825	IBC, FL, LA
HGUS212-4	10⅞	12	6⅞	10⅞	4	(56) 0.162 x 3½	(20) 0.162 x 3½	5,205	11,915	13,330	14,290	14,350	4,730	10,280	12,420	12,420	12,420	IBC, FL, LA
HGUS214-4	12⅞	12	6⅞	12⅞	4	(66) 0.162 x 3½	(22) 0.162 x 3½	5,360	13,860	14,350	14,350	14,350	4,915	11,960	12,420	12,420	12,420	IBC, FL, LA
4x Sizes																		
LUS46	4⅞	18	3⅝	4¾	2	(4) 0.162 x 3½	(4) 0.162 x 3½	1,060	1,030	1,170	1,265	1,595	910	885	1,005	1,090	1,370	IBC, FL, LA
HGUS46	4⅞	12	3⅝	4⅞	4	(20) 0.162 x 3½	(8) 0.162 x 3½	2,155	4,355	4,875	5,230	5,575	2,155	3,755	4,875	5,230	5,255	
HHUS46	4⅞	14	3⅝	5⅞	3	(14) 0.162 x 3½	(6) 0.162 x 3½	1,320	2,830	3,190	3,415	4,250	1,135	2,435	2,745	2,935	3,655	
LUS48	4⅞	18	3⅝	6¾	2	(6) 0.162 x 3½	(4) 0.162 x 3½	1,060	1,315	1,490	1,610	2,030	910	1,130	1,280	1,385	1,745	
HUS48	6⅞	14	3⅝	7	2	(6) 0.162 x 3½	(6) 0.162 x 3½	1,320	1,580	1,790	1,930	2,415	1,135	1,360	1,540	1,660	2,075	
HHUS48	6½	14	3⅝	7½	3	(22) 0.162 x 3½	(8) 0.162 x 3½	1,760	4,265	4,810	5,155	5,980	1,515	3,670	4,135	4,435	5,145	
HGUS48	6⅞	12	3⅝	7⅞	4	(36) 0.162 x 3½	(12) 0.162 x 3½	3,235	7,460	7,460	7,460	7,460	2,780	6,415	6,415	6,415	6,415	
LUS410	6¼	18	3⅝	8¾	2	(8) 0.162 x 3½	(6) 0.162 x 3½	1,445	1,830	2,075	2,245	2,830	1,245	1,575	1,785	1,930	2,435	
HHUS410	8⅞	14	3⅝	9	3	(30) 0.162 x 3½	(10) 0.162 x 3½	3,550	5,705	6,435	6,485	6,485	3,265	4,905	5,535	5,575	5,575	
HGUS410	8⅞	12	3⅝	9⅞	4	(46) 0.162 x 3½	(16) 0.162 x 3½	4,095	9,100	9,100	9,100	9,100	3,520	7,825	7,825	7,825	7,825	
HGUS412	10⅞	12	3⅝	10⅞	4	(56) 0.162 x 3½	(20) 0.162 x 3½	5,205	11,915	13,330	14,290	14,350	4,730	10,280	12,420	12,420	12,420	
HGUS414	11⅞	12	3⅝	12⅞	4	(66) 0.162 x 3½	(22) 0.162 x 3½	5,360	13,860	14,350	14,350	14,350	4,915	11,960	12,420	12,420	12,420	
Double 4x Sizes																		
HGUS7.37/10	8⅞	12	7⅞	8⅞	4	(46) 0.162 x 3½	(16) 0.162 x 3½	4,095	9,100	9,100	9,100	9,100	3,520	7,825	7,825	7,825	7,825	IBC, FL, LA
HGUS7.37/12	10⅞	12	7⅞	10⅞	4	(56) 0.162 x 3½	(20) 0.162 x 3½	5,205	11,915	13,330	14,290	14,350	4,730	10,280	12,420	12,420	12,420	IBC, FL, LA
HGUS7.37/14	11⅞	12	7⅞	12⅞	4	(66) 0.162 x 3½	(22) 0.162 x 3½	5,360	13,860	14,350	14,350	14,350	4,915	11,960	12,420	12,420	12,420	IBC, FL, LA

- Uplift loads have been increased for earthquake or wind loading with no further increase allowed. Reduce where other loads govern.
- Wind (160) is a download rating.
- Minimum heel height shown is required to achieve full table loads. For less than minimum heel height, see technical bulletin T-C-REDHEEL at strongtie.com.
- Truss chord cross-grain tension may limit allowable loads in accordance with ANSI/TPI 1-2014. Simpson Strong-Tie® Connector Selector™ software includes the evaluation of cross-grain tension in its hanger allowable loads. For additional information, contact Simpson Strong-Tie.
- Loads shown are based on a two-ply 2x carrying member minimum for nailed hangers. With 3x carrying members: when 0.162" x 3½" nails are specified, use 0.162" x 2½" nails into the header and 0.162" x 3½" nails into the joist with no load reduction. When 0.148" x 3" nails are specified, use 0.148" x 2½" nails into the header and 0.148" x 3" nails into the joist with no load reduction. With 2x carrying members: when 0.162" x 3½" nails are specified, use 0.148" x 1½" nails into the header and 0.148" x 3" nails into the joist and reduce the load to 0.64 of the table values. When 0.148" x 3" nails are specified, use 0.148" x 1½" nails into the header and 0.148" x 3" nails into the joist and reduce the load to 0.77 of the table values.
- Fasteners:** Nail dimensions are listed diameter by length. See pp. 21–22 for fastener information.

Face-Mount Hangers — I-Joists, Glulam and SCL

Codes: See p. 11 for Code Reference Key Chart.

I-Joist, Glulam and Structural Composite Lumber Connectors

Actual Joist Size (in.)	Model No.	Carried Member			Dimensions (in.)			Min./Max.	Fasteners (in.)		Allowable Loads						Code Ref.		
		Glulam	SCL	I-Joist	Web Stiff Req'd.	W	H		B	Face	Joist	DF/SP Species Header				SPF/HF Species Header			
												Uplift (160)	Floor (100)	Snow (115)	Roof (125)	Floor (100)		Snow (115)	Roof (125)
1½ x 9½	U210			•	✓	1⅞	7⅞	2	—	(6) 0.148 x 3	(6) 0.148 x 1½	990	1,220	1,380	1,480	1,050	1,185	1,275	
	MIU1.56/9			•	—	1⅞	8⅞	2½	—	(16) 0.162 x 3½	(2) 0.148 x 1½	230	2,305	2,615	2,820	1,980	2,245	2,425	
1½ x 11⅞	U210			•	✓	1⅞	7⅞	2	—	(6) 0.148 x 3	(6) 0.148 x 1½	990	1,220	1,380	1,480	1,050	1,185	1,275	
	MIU1.56/11			•	—	1⅞	11⅞	2½	—	(20) 0.162 x 3½	(2) 0.148 x 1½	230	2,880	3,135	3,135	2,475	2,695	2,695	
1¾ x 5½	HU1.81/5			•	—	1⅞	5⅞	2½	Min.	(12) 0.162 x 3½	(4) 0.148 x 1½	610	1,785	2,015	2,165	1,540	1,735	1,865	
									Max.	(16) 0.162 x 3½	(6) 0.148 x 1½	915	2,380	2,685	2,890	2,050	2,315	2,490	
1¾ x 7¼	HU7			•	—	1⅞	6⅞	2½	Min.	(12) 0.162 x 3½	(4) 0.148 x 1½	610	1,785	2,015	2,165	1,540	1,735	1,865	
									Max.	(16) 0.162 x 3½	(8) 0.148 x 1½	1515	2,380	2,685	2,890	2,050	2,315	2,490	
1¾ x 9½	IUS1.81/9.5			•	—	1⅞	9½	2	—	(8) 0.148 x 3	—	70	950	1,080	1,165	815	925	1,000	
	HU9			•	•	✓	1⅞	9⅞	2½	Min.	(18) 0.162 x 3½	(6) 0.148 x 1½	915	2,680	3,020	3,250	2,305	2,605	2,800
									Max.	(24) 0.162 x 3½	(10) 0.148 x 1½	1,795	3,570	4,030	4,335	3,075	3,470	3,735	
	HUS1.81/10			•	—	1⅞	8⅞	3	—	(30) 0.162 x 3½	(10) 0.162 x 3½	2,675	5,510	5,830	5,830	4,360	4,675	4,885	
	HUCQ1.81/9-SDS			•	—	1⅞	9	3	—	(8) ¼ x 1¾ SDS	(4) ¼ x 1¾ SDS	1,310	2,000	2,300	2,500	1,440	1,655	1,800	
1¾ x 11⅞	MIU1.81/9			•	•	—	1⅞	8⅞	2½	—	(16) 0.162 x 3½	(2) 0.148 x 1½	230	2,305	2,615	2,820	1,980	2,245	2,425
	IUS1.81/11.88			•	—	1⅞	11⅞	2	—	(10) 0.148 x 3	—	70	1,185	1,345	1,455	1,020	1,160	1,250	
	MIU1.81/11			•	•	—	1⅞	11⅞	2½	—	(20) 0.162 x 3½	(2) 0.148 x 1½	230	2,880	3,135	3,135	2,475	2,695	2,695
	HUS1.81/10			•	—	1⅞	8⅞	3	—	(30) 0.162 x 3½	(10) 0.162 x 3½	2,675	5,510	5,830	5,830	4,360	4,675	4,885	
									Min.	(22) 0.162 x 3½	(6) 0.148 x 1½	915	3,275	3,695	3,970	2,820	3,180	3,425	
								Max.	(30) 0.162 x 3½	(10) 0.148 x 1½	1,795	4,465	4,705	4,810	3,845	4,340	4,600		
	HUCQ1.81/11-SDS			•	—	1⅞	11	3	—	(10) ¼ x 1¾ SDS	(4) ¼ x 1¾ SDS	1,310	2,500	2,875	3,125	1,800	2,070	2,250	
1¾ x 14	IUS1.81/14			•	•	—	1⅞	14	2	Min.	(12) 0.148 x 3	—	70	1,420	1,615	1,745	1,220	1,390	1,500
								Max.	(14) 0.148 x 3	—	70	1,660	1,805	1,805	1,425	1,550	1,550		
	MIU1.81/14			•	•	—	1⅞	13⅞	2½	—	(22) 0.162 x 3½	(2) 0.148 x 1½	230	3,170	3,595	3,875	2,725	3,090	3,335
	HUS1.81/10			•	—	1⅞	8⅞	3	—	(30) 0.162 x 3½	(10) 0.162 x 3½	2,675	5,510	5,830	5,830	4,360	4,675	4,885	
	U14			•	•	✓	1⅞	10¼	2	—	(14) 0.162 x 3½	(6) 0.148 x 1½	970	2,015	2,285	2,465	1,735	1,965	2,120
									Min.	(28) 0.162 x 3½	(8) 0.148 x 1½	1,515	4,165	4,420	4,505	3,590	4,050	4,335	
								Max.	(36) 0.162 x 3½	(14) 0.148 x 1½	1,795	5,055	5,275	5,420	4,615	5,000	5,130		
	HUCQ1.81/11-SDS			•	—	1⅞	11	3	—	(10) ¼ x 1¾ SDS	(4) ¼ x 1¾ SDS	1,310	2,500	2,875	3,125	1,800	2,070	2,250	
1¾ x 16	IUS1.81/16			•	—	1⅞	16	2	Min.	(14) 0.148 x 3	—	70	1,660	1,805	1,805	1,425	1,555	1,555	
								Max.	(16) 0.148 x 3	—	70	1,805	1,805	1,805	1,555	1,555	1,555		
	MIU1.81/16			•	—	1⅞	15⅞	2½	—	(24) 0.162 x 3½	(2) 0.148 x 1½	230	3,455	3,920	4,045	2,970	3,370	3,480	
1¾ x 18	MIU1.81/18			•	—	1⅞	17⅞	2½	—	(26) 0.162 x 3½	(2) 0.148 x 1½	230	3,745	4,020	4,045	3,220	3,460	3,480	
2 x 9½	IUS2.06/9.5			•	—	2⅞	9½	2	—	(8) 0.148 x 3	—	70	950	1,080	1,165	815	925	1,000	
	HU2.1/9			•	✓	2⅞	9⅞	2½	—	(14) 0.162 x 3½	(6) 0.148 x 1½	915	2,085	2,350	2,530	1,795	2,025	2,180	
2 x 11⅞	IUS2.06/11.88			•	—	2⅞	11⅞	2	—	(10) 0.148 x 3	—	70	1,185	1,345	1,455	1,020	1,160	1,250	
	MIU2.1/11			•	✓	2⅞	11⅞	2½	—	(20) 0.162 x 3½	(2) 0.148 x 1½	230	2,880	3,135	3,135	2,475	2,695	2,695	
	HU2.1/11			•	✓	2⅞	11	2½	—	(16) 0.162 x 3½	(6) 0.148 x 1½	915	2,380	2,685	2,890	2,050	2,315	2,490	
2 x 14	IUS2.06/14			•	—	2⅞	14	2	Min.	(12) 0.148 x 3	—	70	1,420	1,615	1,745	1,220	1,390	1,500	
								Max.	(14) 0.148 x 3	—	70	1,660	1,805	1,805	1,425	1,555	1,555		
	MIU2.1/11			•	✓	2⅞	11⅞	2½	—	(20) 0.162 x 3½	(2) 0.148 x 1½	230	2,880	3,135	3,135	2,475	2,695	2,695	
	HU2.1/11			•	✓	2⅞	11	2½	—	(16) 0.162 x 3½	(6) 0.148 x 1½	915	2,380	2,685	2,890	2,050	2,315	2,490	
2 x 16	IUS2.06/16			•	—	2⅞	16	2	Min.	(14) 0.148 x 3	—	70	1,660	1,805	1,805	1,425	1,555	1,555	
								Max.	(16) 0.148 x 3	—	70	1,805	1,805	1,805	1,555	1,555	1,555		
	HU2.1/11			•	✓	2⅞	11	2½	—	(16) 0.162 x 3½	(6) 0.148 x 1½	915	2,380	2,685	2,890	2,050	2,315	2,490	
2⅞ x 9½	IUS2.06/9.5			•	—	2⅞	9½	2	—	(8) 0.148 x 3	—	70	950	1,080	1,165	815	925	1,000	
	HU2.1/9			•	✓	2⅞	9⅞	2½	—	(14) 0.162 x 3½	(6) 0.148 x 1½	915	2,085	2,350	2,530	1,795	2,025	2,180	
2⅞ x 11⅞	IUS2.06/11.88			•	—	2⅞	11⅞	2	—	(10) 0.148 x 3	—	70	1,185	1,345	1,455	1,020	1,160	1,250	
	MIU2.1/11			•	✓	2⅞	11⅞	2½	—	(20) 0.162 x 3½	(2) 0.148 x 1½	230	2,880	3,135	3,135	2,475	2,695	2,695	
	HU2.1/11			•	✓	2⅞	11	2½	—	(16) 0.162 x 3½	(6) 0.148 x 1½	915	2,380	2,685	2,890	2,050	2,315	2,490	

IBC, FL, LA

See footnotes on p. 152.

Face-Mount Hangers — I-Joists, Glulam and SCL

Codes: See p. 11 for Code Reference Key Chart.

Actual Joist Size (in.)	Model No.	Carried Member				Dimensions (in.)			Fasteners (in.)		Allowable Loads						Code Ref.	
		Glulam	SCL	I-Joist	Web Stiff Req'd.	W	H	B	Min./Max.	Face	Joist	DF/SP Species Header			SPF/HF Species Header			
												Uplift (160)	Floor (100)	Snow (115)	Roof (125)	Floor (100)		Snow (115)
2 1/16 x 14	IUS2.06/14				• —	2 1/8	14	2	—	(12) 0.148 x 3	—	70	1,420	1,615	1,745	1,220	1,390	1,500
	MIU2.1/11				• ✓	2 1/8	11 1/16	2 1/2	—	(20) 0.162 x 3 1/2	(2) 0.148 x 1 1/2	230	2,880	3,135	3,135	2,475	2,695	2,695
	HU2.1/11				• ✓	2 1/8	11	2 1/2	—	(16) 0.162 x 3 1/2	(6) 0.148 x 1 1/2	915	2,380	2,685	2,890	2,050	2,315	2,490
2 1/16 x 16	IUS2.06/16				• —	2 1/8	16	2	—	(14) 0.148 x 3	—	70	1,660	1,805	1,805	1,425	1,555	1,555
	MIU2.1/11				• ✓	2 1/8	11 1/16	2 1/2	—	(20) 0.162 x 3 1/2	(2) 0.148 x 1 1/2	230	2,880	3,135	3,135	2,475	2,695	2,695
	HU2.1/11				• ✓	2 1/8	11	2 1/2	—	(16) 0.162 x 3 1/2	(6) 0.148 x 1 1/2	915	2,380	2,685	2,890	2,050	2,315	2,490
2 1/4 x 9 1/2 to 20	2 1/4"-wide joists use the same hangers as 2 5/16"-wide joists with the following load adjustments to the table loads: IUS download is the lesser of the table load or 1,400 lb.; IUS uplift is 55 lb.; MIU and U downloads are the lesser of the table load or 2,140 lb.																	
2 5/16 x 9 1/2	IUS2.37/9.5				• —	2 7/16	9 1/2	2	—	(8) 0.148 x 3	—	70	950	1,080	1,165	815	925	1,000
	MIU2.37/9				• —	2 3/8	9	2 1/2	—	(16) 0.162 x 3 1/2	(2) 0.148 x 1 1/2	230	2,305	2,615	2,820	1,980	2,245	2,425
	U3510/14				• ✓	2 5/16	9	2	—	(14) 0.162 x 3 1/2	(6) 0.148 x 1 1/2	970	2,015	2,285	2,465	1,735	1,965	2,120
	HU359 / HUC359				• ✓	2 3/8	9	2 1/2	Min.	(14) 0.162 x 3 1/2	(6) 0.148 x 1 1/2	915	2,085	2,350	2,530	1,795	2,025	2,180
Max.		(18) 0.162 x 3 1/2	(10) 0.148 x 1 1/2	1,795	2,680				3,020	3,250	2,305	2,605	2,800					
2 5/16 x 11 7/8	IUS2.37/11.88				• —	2 7/16	11 7/8	2	—	(10) 0.148 x 3	—	70	1,185	1,345	1,455	1,020	1,160	1,250
	MIU2.37/11				• —	2 3/8	11 1/16	2 1/2	—	(20) 0.162 x 3 1/2	(2) 0.148 x 1 1/2	230	2,880	3,135	3,135	2,475	2,695	2,695
	U3516/20				• ✓	2 5/16	10 9/16	2	—	(16) 0.162 x 3 1/2	(6) 0.148 x 1 1/2	970	2,305	2,615	2,820	1,980	2,245	2,425
	HU3511 / HUC3511				• ✓	2 3/8	10 19/16	2 1/2	Min.	(16) 0.162 x 3 1/2	(6) 0.148 x 1 1/2	915	2,380	2,685	2,890	2,050	2,315	2,490
Max.		(22) 0.162 x 3 1/2	(10) 0.148 x 1 1/2	1,795	3,275				3,695	3,970	2,820	3,180	3,425					
2 5/16 x 14	IUS2.37/14				• —	2 7/16	14	2	Min.	(12) 0.148 x 3	—	70	1,420	1,615	1,745	1,220	1,390	1,500
		Max.	(14) 0.148 x 3	—	70				1,660	1,805	1,805	1,425	1,555	1,555				
	MIU2.37/14				• —	2 3/8	13 1/2	2 1/2	—	(22) 0.162 x 3 1/2	(2) 0.148 x 1 1/2	230	3,170	3,595	3,875	2,725	3,090	3,335
		U3516/20							• ✓	2 5/16	10 9/16	2	—	(16) 0.162 x 3 1/2	(6) 0.148 x 1 1/2	970	2,305	2,615
HU3514 / HUC3514				• ✓	2 3/8	12 1/2	2 1/2	Min.	(18) 0.162 x 3 1/2	(8) 0.148 x 1 1/2	1,515	2,680	3,020	3,250	2,305	2,605	2,800	
	Max.	(24) 0.162 x 3 1/2	(12) 0.148 x 1 1/2	1,795				3,570	4,030	4,335	3,075	3,470	3,735					
2 5/16 x 16	IUS2.37/16				• —	2 7/16	16	2	Min.	(14) 0.148 x 3	—	70	1,660	1,805	1,805	1,425	1,555	1,555
		Max.	(16) 0.148 x 3	—	70				1,805	1,805	1,805	1,555	1,555	1,555				
	MIU2.37/16				• —	2 3/8	15 1/2	2 1/2	—	(24) 0.162 x 3 1/2	(2) 0.148 x 1 1/2	230	3,455	3,920	4,045	2,970	3,370	3,480
		U3516/20							• ✓	2 5/16	10 9/16	2	—	(16) 0.162 x 3 1/2	(6) 0.148 x 1 1/2	970	2,305	2,615
HU3516/22 / HUC3516/22				• ✓	2 3/8	14 1/4	2 1/2	—	(20) 0.162 x 3 1/2	(8) 0.148 x 1 1/2	1,515	2,975	3,360	3,610	2,565	2,895	3,110	
	Min.	(18) 0.162 x 3 1/2	(8) 0.148 x 1 1/2	1,515				2,680	3,020	3,250	2,305	2,605	2,800					
2 5/16 x 18	MIU2.37/18				• —	2 3/8	17 1/2	2 1/2	—	(26) 0.162 x 3 1/2	(2) 0.148 x 1 1/2	230	3,745	4,045	4,045	3,220	3,480	3,480
		U3524/30							• ✓	2 3/8	18	2 1/2	Min.	(18) 0.162 x 3 1/2	(8) 0.148 x 1 1/2	1,515	2,680	3,020
2 5/16 x 20	MIU2.37/20				• —	2 3/8	19 1/2	2 1/2	—	(28) 0.162 x 3 1/2	(2) 0.148 x 1 1/2	230	4,030	4,060	4,060	3,465	3,495	3,495
		U3524/30							• ✓	2 3/8	18	2 1/2	Min.	(18) 0.162 x 3 1/2	(8) 0.148 x 1 1/2	1,515	2,680	3,020
2 5/16 x 22 to 30	MIU2.37/20				• ✓	2 3/8	19 1/2	2 1/2	—	(28) 0.162 x 3 1/2	(2) 0.148 x 1 1/2	230	4,030	4,060	4,060	3,465	3,495	3,495
		U3524/30							• ✓	2 3/8	18	2 1/2	Min.	(18) 0.162 x 3 1/2	(8) 0.148 x 1 1/2	1,515	2,680	3,020
2 1/2 x 9 1/2	IUS2.56/9.5				• —	2 5/8	9 1/2	2	—	(8) 0.148 x 3	—	70	950	1,080	1,165	815	925	1,000
		MIU2.56/9							• —	2 5/16	8 15/16	2 1/2	—	(16) 0.162 x 3 1/2	(2) 0.148 x 1 1/2	230	2,305	2,615
2 1/2 x 11 7/8	U310				• ✓	2 5/16	8 7/8	2	—	(14) 0.162 x 3 1/2	(6) 0.148 x 1 1/2	970	1,705	1,930	2,075	1,465	1,660	1,785
		HU310 / HUC310							• ✓	2 5/16	8 7/8	2 1/2	—	(14) 0.162 x 3 1/2	(6) 0.148 x 1 1/2	915	2,085	2,350
	IUS2.56/11.88				• —	2 5/8	11 7/8	2	—	(10) 0.148 x 3	—	70	1,185	1,345	1,455	1,020	1,160	1,250
		MIU2.56/11							• —	2 5/16	11 1/16	2 1/2	—	(20) 0.162 x 3 1/2	(2) 0.148 x 1 1/2	230	2,880	3,135
HU312 / HUC312				• ✓	2 5/16	10 1/2	2	—	(16) 0.162 x 3 1/2	(6) 0.148 x 1 1/2	970	1,945	2,205	2,375	1,675	1,895	2,045	
	U314							• ✓	2 5/16	10 9/16	2 1/2	—	(16) 0.162 x 3 1/2	(6) 0.148 x 1 1/2	915	2,380	2,685	2,890
2 1/2 x 14	IUS2.56/14				• —	2 5/8	14	2	Min.	(12) 0.148 x 3	—	70	1,420	1,615	1,745	1,220	1,390	1,500
		Max.	(14) 0.148 x 3	—	70				1,660	1,805	1,805	1,425	1,555	1,555				
	MIU2.56/14				• —	2 5/16	13 7/16	2 1/2	—	(22) 0.162 x 3 1/2	(2) 0.148 x 1 1/2	230	3,170	3,595	3,875	2,725	3,090	3,335
		U314							• ✓	2 5/16	10 1/2	2	—	(16) 0.162 x 3 1/2	(6) 0.148 x 1 1/2	970	1,945	2,205
HU314 / HUC314				• ✓	2 5/16	12 3/8	2 1/2	—	(18) 0.162 x 3 1/2	(8) 0.148 x 1 1/2	1,515	2,680	3,020	3,250	2,305	2,605	2,800	

I-Joist, Glulam and Structural Composite Lumber Connectors

C-C-2021 © 2021 SIMPSON STRONG-TIE COMPANY, INC.

See footnotes on p. 152.

Face-Mount Hangers — I-Joists, Glulam and SCL

These products are available with additional corrosion protection. For more information, see p. 14.

Codes: See p. 11 for Code Reference Key Chart.

I-Joist, Glulam and Structural Composite Lumber Connectors

Actual Joist Size (in.)	Model No.	Carried Member			Dimensions (in.)			Min./Max.	Fasteners (in.)		Allowable Loads						Code Ref.		
		Glulam	SCL	I-joist	Web Stiff Req.	W	H		B	Face	Joist	DF/SP Species Header				SPF/HF Species Header			
												Uplift (160)	Floor (100)	Snow (115)	Roof (125)	Floor (100)		Snow (115)	Roof (125)
2½ x 16	IUS2.56/16			•	—	2%	16	2	Min.	(14) 0.148 x 3	—	70	1,660	1,805	1,805	1,425	1,555	1,555	IBC, FL, LA
	MIU2.56/16			•	—	2%	15½	2½	Max.	(16) 0.148 x 3	—	70	1,805	1,805	1,805	1,555	1,555	1,555	
	U314			•	✓	2%	10½	2	—	(16) 0.162 x 3½	(6) 0.148 x 1½	970	1,945	2,205	2,375	1,675	1,895	2,045	
	HU316 / HUC316			•	✓	2%	14¾	2½	—	(20) 0.162 x 3½	(8) 0.148 x 1½	1,515	2,975	3,360	3,610	2,565	2,895	3,110	
2½ x 18	MIU2.56/18			•	—	2%	17½	2½	—	(26) 0.162 x 3½	(2) 0.148 x 1½	230	3,745	4,045	4,045	3,220	3,480	3,480	
	HU316 / HUC316			•	✓	2%	14½	2½	—	(20) 0.162 x 3½	(8) 0.148 x 1½	1,515	2,975	3,360	3,610	2,565	2,895	3,110	
2½ x 20	MIU2.56/20			•	—	2%	19½	2½	—	(28) 0.162 x 3½	(2) 0.148 x 1½	230	4,030	4,060	4,060	3,465	3,495	3,495	
2½ x 22 to 26	MIU2.56/20			•	✓	2%	19½	2½	—	(28) 0.162 x 3½	(2) 0.148 x 1½	230	4,030	4,060	4,060	3,465	3,495	3,495	
2¾ x 9¼ to 26	2¾" wide joists use the same hangers as 2½" wide joists and have the same loads.																		
3 x 9½	MIU3.12/9			•	—	3%	9¼	2½	—	(16) 0.162 x 3½	(2) 0.148 x 1½	230	2,305	2,615	2,820	1,980	2,245	2,425	
	HU210-2 / HUC210-2			•	✓	3%	8¾	2½	Max.	(18) 0.162 x 3½	(10) 0.148 x 3	1,795	2,680	3,020	3,250	2,305	2,605	2,800	
3 x 11¾	MIU3.12/11			•	—	3%	11½	2½	—	(20) 0.162 x 3½	(2) 0.148 x 1½	230	2,880	3,135	3,135	2,475	2,695	2,695	
	HU212-2 / HUC212-2			•	✓	3%	10¾	2½	Max.	(22) 0.162 x 3½	(10) 0.148 x 3	1,795	3,275	3,695	3,970	2,820	3,180	3,425	
3¾ glulam	HU3.25/12 / HUC3.25/12	•				3¼	11¼	2½	—	(24) 0.162 x 3½	(12) 0.148 x 3	1,795	3,570	4,030	4,335	3,075	3,470	3,735	
	HU3.25/16 / HUC3.25/16	•				3¼	13¼	2½	Min.	(20) 0.162 x 3½	(8) 0.148 x 3	1,515	2,975	3,360	3,610	2,560	2,890	3,105	
	HU3.25/16 / HUC3.25/16	•				3¼	13¼	2½	Max.	(26) 0.162 x 3½	(12) 0.148 x 3	1,795	3,870	4,365	4,695	3,330	3,755	4,040	
	HUCQ210-2-SDS	•				3¼	9	3	—	(12) ¼ x 2½ SDS	(6) ¼ x 2½ SDS	2,345	4,315	4,315	4,315	3,600	3,710	3,710	
	HGUS3.25/10	•				3¼	8%	4	—	(46) 0.162 x 3½	(16) 0.162 x 3½	4,095	9,100	9,100	9,100	7,825	7,825	7,825	
	HGUS3.25/12	•				3¼	10%	4	—	(56) 0.162 x 3½	(20) 0.162 x 3½	5,205	11,915	13,330	14,290	10,015	11,550	12,045	
3½ x 5¼	LGU3.25-SDS	•				3¼	8 to 30	4½	—	(16) ¼ x 2½ SDS	(12) ¼ x 2½ SDS	5,555	6,720	7,310	7,310	4,840	5,265	5,265	
	HHUS46	•	•			3%	5½	3	—	(14) 0.162 x 3½	(6) 0.162 x 3½	1,320	2,785	3,155	3,405	2,395	2,715	2,930	
3½ x 7¼	HGUS46	•	•			3%	4¾	4	—	(20) 0.162 x 3½	(8) 0.162 x 3½	2,155	4,355	4,875	5,230	3,755	4,875	5,230	
	HUS48	•	•			3¾	6¼	2	—	(6) 0.162 x 3½	(6) 0.162 x 3½	1,320	1,595	1,815	1,960	1,365	1,555	1,680	
3½ x 9½	HHUS48	•	•			3%	7½	3	—	(22) 0.162 x 3½	(8) 0.162 x 3½	1,780	4,210	4,770	5,140	3,615	4,095	4,415	
	HGUS48	•	•			3%	7¼	4	—	(36) 0.162 x 3½	(12) 0.162 x 3½	3,235	7,460	7,460	7,460	6,415	6,415	6,415	
3½ x 9½	IUS3.56/9.5			•	—	3%	9½	2	—	(10) 0.148 x 3	—	70	1,185	1,345	1,455	1,020	1,160	1,250	
	MIU3.56/9			•	•	3%	8¾	2½	—	(16) 0.162 x 3½	(2) 0.148 x 1½	210	2,305	2,615	2,820	1,980	2,245	2,425	
	U410			•	•	✓	3%	8%	2	—	(14) 0.162 x 3½	(6) 0.148 x 3	970	2,015	2,285	2,465	1,735	1,965	2,120
	HUS410			•	•	—	3¾	8¼	2	—	(8) 0.162 x 3½	(8) 0.162 x 3½	2,990	2,125	2,420	2,615	1,820	2,070	2,240
	HHUS410			•	•	—	3%	9	3	—	(30) 0.162 x 3½	(10) 0.162 x 3½	3,565	5,635	6,380	6,445	4,845	5,486	5,545
	HU410/HUC410			•	•	✓	3¾	8%	2½	Min.	(14) 0.162 x 3½	(6) 0.148 x 3	1,135	2,085	2,350	2,530	1,795	2,020	2,165
	HU410/HUC410			•	•	✓	3¾	8%	2½	Max.	(18) 0.162 x 3½	(10) 0.148 x 3	1,795	2,680	3,020	3,250	2,305	2,605	2,800
	HUCQ410-SDS			•	•	—	3¾	9	3	—	(12) ¼ x 2½ SDS	(6) ¼ x 2½ SDS	2,265	4,500	4,500	4,500	3,240	3,240	3,240
	HGUS410			•	•	—	3%	9¼	4	—	(46) 0.162 x 3½	(16) 0.162 x 3½	4,095	9,100	9,100	9,100	7,825	7,825	7,825
	LGU3.63-SDS			•	•	—	3%	8 to 30	4½	—	(16) ¼ x 2½ SDS	(12) ¼ x 2½ SDS	5,555	6,720	6,720	6,720	4,840	4,840	4,840
MGU3.63-SDS			•	•	—	3%	9¼ to 30	4½	—	(24) ¼ x 2½ SDS	(16) ¼ x 2½ SDS	7,260	9,450	9,450	9,450	6,805	6,805	6,805	
3½ x 11¾	IUS3.56/11.88			•	—	3%	11¾	2	—	(12) 0.148 x 3	—	70	1,420	1,615	1,745	1,220	1,390	1,485	
	MIU3.56/11			•	—	3%	11½	2½	—	(20) 0.162 x 3½	(2) 0.148 x 1½	210	2,880	3,135	3,135	2,475	2,695	2,695	
	U414			•	•	✓	3¾	10	2	—	(16) 0.162 x 3½	(6) 0.148 x 3	970	2,305	2,615	2,820	1,980	2,245	2,425
	HHUS410			•	•	—	3%	9	3	—	(30) 0.162 x 3½	(10) 0.162 x 3½	3,565	5,635	6,380	6,445	4,845	5,486	5,545
	HUS412			•	•	—	3¾	10½	2	—	(10) 0.162 x 3½	(10) 0.162 x 3½	3,435	2,660	3,025	3,265	2,275	2,590	2,795
	HU412 / HUC412			•	•	—	3¾	10¾	2½	Min.	(16) 0.162 x 3½	(6) 0.148 x 3	1,135	2,380	2,685	2,890	2,050	2,315	2,490
	HU412 / HUC412			•	•	—	3¾	10¾	2½	Max.	(22) 0.162 x 3½	(10) 0.148 x 3	1,795	3,275	3,695	3,970	2,820	3,180	3,425
	HUCQ412-SDS			•	•	—	3¾	11	—	(14) ¼ x 2½ SDS	(6) ¼ x 2½ SDS	2,265	5,045	5,045	5,045	3,630	3,630	3,630	
	HGUS412			•	•	—	3%	10¾	4	—	(56) 0.162 x 3½	(20) 0.162 x 3½	5,205	11,915	13,330	14,290	10,280	12,160	12,420
	LGU3.63-SDS			•	•	—	3%	8 to 30	4½	—	(16) ¼ x 2½ SDS	(12) ¼ x 2½ SDS	5,555	6,720	6,720	6,720	4,840	4,840	4,840
MGU3.63-SDS			•	•	—	3%	9¼ to 30	4½	—	(24) ¼ x 2½ SDS	(16) ¼ x 2½ SDS	7,260	9,450	9,450	9,450	6,805	6,805	6,805	
HGU3.63-SDS			•	•	—	3%	11 to 30	4½	—	(36) ¼ x 2½ SDS	(24) ¼ x 2½ SDS	9,460	13,160	13,160	13,160	9,475	9,475	9,475	

C-C-2021 © 2021 SIMPSON STRONG-TIE COMPANY, INC.

See footnotes on p. 152.

Face-Mount Hangers — I-Joists, Glulam and SCL

These products are available with additional corrosion protection. For more information, see p. 14.

SS For stainless-steel fasteners, see p. 21.

Codes: See p. 11 for Code Reference Key Chart.

Actual Joist Size (in.)	Model No.	Carried Member				Dimensions (in.)			Min./Max.	Fasteners (in.)		Allowable Loads						Code Ref.		
		Glulam	SCL	I-Joist	Web Stiff Req'd.	W	H	B		Face	Joist	DF/SP Species Header			SPF/HF Species Header					
												Uplift (160)	Floor (100)	Snow (115)	Roof (125)	Floor (100)	Snow (115)		Roof (125)	
3½ x 14	IUS3.56/14			•	—	3%	14	2	Min.	(12) 0.148 x 3	—	70	1,420	1,615	1,745	1,220	1,390	1,500	IBC, FL, LA	
				•	—	3%	14	2	Max.	(14) 0.148 x 3	—	70	1,660	1,805	1,805	1,425	1,555	1,555		
	MIU3.56/14			•	—	3½%	13½%	2½	—	(22) 0.162 x 3½	(2) 0.148 x 1½	210	3,170	3,595	3,875	2,725	3,090	3,335		
	U414	•	•	•	✓	3½%	10	2	—	(16) 0.162 x 3½	(6) 0.148 x 3	970	2,305	2,615	2,820	1,980	2,245	2,425		
	HHUS410	•	•	•	—	3%	9	3	—	(30) 0.162 x 3½	(10) 0.162 x 3½	3,565	5,635	6,380	6,445	4,845	5,486	5,545		
	HUS412	•	•	•	—	3½%	10½	2	—	(10) 0.162 x 3½	(10) 0.162 x 3½	3,635	2,660	3,025	3,265	2,275	2,590	2,795		
	HU414	•	•	•	✓	3½%	12%	2½	Max.	(24) 0.162 x 3½	(12) 0.148 x 3	1,795	3,570	4,030	4,335	3,075	3,470	3,735		
	HU416 / HUC416	•	•	•	✓	3½%	13%	2½	Min.	(20) 0.162 x 3½	(8) 0.148 x 3	1,515	2,975	3,360	3,610	2,565	2,895	3,110		
					•	—	3½%	13%	2½	Max.	(26) 0.162 x 3½	(12) 0.148 x 3	1,795	3,870	4,365	4,695	3,330	3,760		4,045
		HUCQ412-SDS	•	•	•	—	3½%	11	3	—	(14) ¼ x 2½ SDS	(6) ¼ x 2½ SDS	2,265	5,045	5,045	5,045	3,630	3,630		3,630
	HGUS414	•	•	•	—	3%	12¾	4	—	(66) 0.162 x 3½	(22) 0.162 x 3½	5,360	13,860	14,350	14,350	11,115	12,420	12,420		
	LGU3.63-SDS	•	•	•	—	3%	8 to 30	4½	—	(16) ¼ x 2½ SDS	(12) ¼ x 2½ SDS	5,555	6,720	6,720	6,720	4,840	4,840	4,840		
	MGU3.63-SDS	•	•	•	—	3%	9¼ to 30	4½	—	(24) ¼ x 2½ SDS	(16) ¼ x 2½ SDS	7,260	9,450	9,450	9,450	6,805	6,805	6,805		
	HGU3.63-SDS	•	•	•	—	3%	11 to 30	4½	—	(36) ¼ x 2½ SDS	(24) ¼ x 2½ SDS	9,460	13,160	13,160	13,160	9,475	9,475	9,475		
3½ x 16	IUS3.56/16			•	—	3%	16	2	Min.	(14) 0.148 x 3	—	70	1,660	1,805	1,805	1,425	1,555	1,555	IBC, FL, LA	
				•	—	3½%	15%	2½	Max.	(16) 0.148 x 3	—	70	1,805	1,805	1,805	1,555	1,555	1,555		
	MIU3.56/16	•	•	•	—	3½%	15%	2½	—	(24) 0.162 x 3½	(2) 0.148 x 1½	210	3,455	3,920	4,045	2,970	3,370	3,480		
	HU416 / HUC416	•	•	•	—	3½%	13%	2½	Min.	(20) 0.162 x 3½	(8) 0.148 x 3	1,515	2,975	3,360	3,610	2,565	2,895	3,110		
					•	—	3½%	13%	2½	Max.	(26) 0.162 x 3½	(12) 0.148 x 3	1,795	3,870	4,365	4,695	3,330	3,760		4,045
	HGUS414	•	•	•	—	3%	12¾	4	—	(66) 0.162 x 3½	(22) 0.162 x 3½	5,360	13,860	14,350	14,350	11,115	12,420	12,420		
	HUCQ412-SDS	•	•	•	—	3½%	11	3	—	(14) ¼ x 2½ SDS	(6) ¼ x 2½ SDS	2,265	5,045	5,045	5,045	3,630	3,630	3,630		
	LGU3.63-SDS	•	•	•	—	3%	8 to 30	4½	—	(16) ¼ x 2½ SDS	(12) ¼ x 2½ SDS	5,555	6,720	6,720	6,720	4,840	4,840	4,840		
	MGU3.63-SDS	•	•	•	—	3%	9¼ to 30	4½	—	(24) ¼ x 2½ SDS	(16) ¼ x 2½ SDS	7,260	9,450	9,450	9,450	6,805	6,805	6,805		
	HGU3.63-SDS	•	•	•	—	3%	11 to 30	4½	—	(36) ¼ x 2½ SDS	(24) ¼ x 2½ SDS	9,895	14,145	14,145	14,145	10,185	10,185	10,185		
3½ x 18	MIU3.56/18			•	—	3½%	17%	2½	—	(26) 0.162 x 3½	(2) 0.148 x 1½	210	3,745	4,045	4,045	3,220	3,480	3,480	IBC, FL, LA	
	HU416 / HUC416	•	•	•	✓	3½%	13%	2½	Min.	(20) 0.162 x 3½	(8) 0.148 x 3	1,515	2,975	3,360	3,610	2,565	2,895	3,110		
	HGUS414	•	•	•	—	3%	12¾	4	—	(66) 0.162 x 3½	(22) 0.162 x 3½	5,360	13,860	14,350	14,350	11,115	12,420	12,420		
	HUCQ412-SDS	•	•	•	—	3½%	11	3	—	(14) ¼ x 2½ SDS	(6) ¼ x 2½ SDS	2,265	5,045	5,045	5,045	3,630	3,630	3,630		
	LGU3.63-SDS	•	•	•	—	3%	8 to 30	4½	—	(16) ¼ x 2½ SDS	(12) ¼ x 2½ SDS	5,555	6,720	6,720	6,720	4,840	4,840	4,840		
	MGU3.63-SDS	•	•	•	—	3%	9¼ to 30	4½	—	(24) ¼ x 2½ SDS	(16) ¼ x 2½ SDS	7,260	9,450	9,450	9,450	6,805	6,805	6,805		
	HGU3.63-SDS	•	•	•	—	3%	11 to 30	4½	—	(36) ¼ x 2½ SDS	(24) ¼ x 2½ SDS	9,460	13,160	13,160	13,160	9,475	9,475	9,475		
3½ x 20	MIU3.56/20			•	—	3½%	19%	2½	—	(28) 0.162 x 3½	(2) 0.148 x 1½	210	4,030	4,060	4,060	3,465	3,495	3,495	IBC, FL, LA	
				•	✓	3½%	19%	2½	—	(28) 0.162 x 3½	(2) 0.148 x 1½	210	4,030	4,060	4,060	3,465	3,495	3,495		
	LGU3.63-SDS	•	•	•	—	3%	8 to 30	4½	—	(16) ¼ x 2½ SDS	(12) ¼ x 2½ SDS	5,555	6,720	6,720	6,720	4,840	4,840	4,840		
	MGU3.63-SDS	•	•	•	—	3%	9¼ to 30	4½	—	(24) ¼ x 2½ SDS	(16) ¼ x 2½ SDS	7,260	9,450	9,450	9,450	6,805	6,805	6,805		
4 x 9½	MIU4.12/9	•	•	•	—	4½%	9½%	2½	—	(16) 0.162 x 3½	(2) 0.148 x 1½	210	2,305	2,615	2,820	1,980	2,245	2,425	IBC, FL, LA	
	HU4.12/9 / HUC4.12/9	•	•	•	✓	4½%	8%	2½	Max.	(18) 0.162 x 3½	(10) 0.148 x 3	1,795	2,680	3,020	3,250	2,305	2,605	2,800		
4 x 11½	MIU4.12/11	•	•	•	—	4½%	11½%	2½	—	(20) 0.162 x 3½	(2) 0.148 x 1½	210	2,880	3,135	3,135	2,475	2,695	2,695	IBC, FL, LA	
	HU4.12/11 / HUC4.12/11	•	•	•	✓	4½%	10½%	2½	Max.	(22) 0.162 x 3½	(10) 0.148 x 3	1,795	3,275	3,695	3,970	2,820	3,180	3,425		
4 x 14	MIU4.12/14	•	•	•	—	4½%	13%	2½	—	(22) 0.162 x 3½	(2) 0.148 x 1½	210	3,170	3,595	3,875	2,725	3,090	3,335	IBC, FL, LA	
	HU4.12/11 / HUC4.12/11	•	•	•	✓	4½%	10½%	2½	Max.	(22) 0.162 x 3½	(10) 0.148 x 3	1,795	3,275	3,695	3,970	2,820	3,180	3,425		
4 x 16	MIU4.12/16	•	•	•	—	4½%	15%	2½	—	(24) 0.162 x 3½	(2) 0.148 x 1½	210	3,455	3,920	4,045	2,970	3,370	3,480	IBC, FL, LA	
	HU4.12/11 / HUC4.12/11	•	•	•	✓	4½%	10½%	2½	Max.	(22) 0.162 x 3½	(10) 0.148 x 3	1,795	3,275	3,695	3,970	2,820	3,180	3,425		
4½ x 9½	MIU4.28/9	•	•	•	—	4¾	9	2½	—	(16) 0.162 x 3½	(2) 0.148 x 1½	210	2,305	2,615	2,820	1,980	2,245	2,425	IBC, FL, LA	
	HU4.28/9 / HUC4.28/9	•	•	•	✓	4¾	9	2½	—	(18) 0.162 x 3½	(8) 0.148 x 3	1,515	2,680	3,020	3,250	2,305	2,605	2,800		
4½ x 11½	MIU4.28/11	•	•	•	—	4¾	11½	2½	—	(20) 0.162 x 3½	(2) 0.148 x 1½	210	2,880	3,135	3,135	2,475	2,695	2,695	IBC, FL, LA	
	HU4.28/11 / HUC4.28/11	•	•	•	✓	4¾	11	2½	—	(22) 0.162 x 3½	(8) 0.148 x 3	1,515	3,275	3,695	3,970	2,820	3,180	3,425		
4½ x 14	MIU4.28/14	•	•	•	—	4¾	13½	2½	—	(22) 0.162 x 3½	(2) 0.148 x 1½	210	3,170	3,595	3,875	2,725	3,090	3,335	IBC, FL, LA	
4½ x 16	MIU4.28/16	•	•	•	—	4¾	15½	2½	—	(24) 0.162 x 3½	(2) 0.148 x 1½	210	3,455	3,920	4,045	2,970	3,370	3,480	IBC, FL, LA	

See footnotes on p. 152.

Face-Mount Hangers — I-Joists, Glulam and SCL

Codes: See p. 11 for Code Reference Key Chart.

I-Joist, Glulam and Structural Composite Lumber Connectors

Actual Joist Size (in.)	Model No.	Carried Member			Dimensions (in.)			Min./Max.	Fasteners (in.)		Allowable Loads						Code Ref.		
		Glulam	SCL	I-joist	Web Stiff Req.	W	H		B	Face	Joist	DF/SP Species Header				SPF/HF Species Header			
												Uplift (160)	Floor (100)	Snow (115)	Roof (125)	Floor (100)		Snow (115)	Roof (125)
4½ x 9½ to 20	Double 2 ¼"-wide joists use the same hangers as double 2 5⁄16"-wide joists with the following loads adjustments: MIU and U downloads are the lesser of the table load or 2,140 lb.																		
4½ x 9½	MIU4.75/9			•	—	4¾	9 1⁄16	2½	—	(16) 0.162 x 3 ½	(2) 0.148 x 1 ½	210	2,305	2,615	2,820	1,980	2,245	2,425	
	U3510-2			•	✓	4¾	8¾	2	—	(14) 0.162 x 3 ½	(6) 0.148 x 3	970	2,015	2,285	2,465	1,735	1,965	2,120	
	HU4.75/9 / HUC4.75/9			•	✓	4¾	9	2½	—	(18) 0.162 x 3 ½	(8) 0.148 x 3	1,515	2,680	3,020	3,250	2,305	2,605	2,800	
4½ x 11 7⁄8	MIU4.75/11			•	—	4¾	11 1⁄16	2½	—	(20) 0.162 x 3 ½	(2) 0.148 x 1 ½	210	2,880	3,135	3,135	2,475	2,695	2,695	
	U3512-2			•	✓	4¾	11 ¼	2	—	(16) 0.162 x 3 ½	(6) 0.148 x 3	970	2,305	2,615	2,820	1,980	2,245	2,425	
	HU4.75/11 / HUC4.75/11			•	✓	4¾	11	2½	—	(22) 0.162 x 3 ½	(8) 0.148 x 3	1,515	3,275	3,695	3,970	2,820	3,180	3,425	
4½ x 14	MIU4.75/14			•	—	4¾	13 ½	2½	—	(22) 0.162 x 3 ½	(2) 0.148 x 1 ½	210	3,170	3,595	3,875	2,725	3,090	3,335	
	HU3514-2 / HUC3514-2			•	✓	4¾	13 ¼	2½	—	(18) 0.162 x 3 ½	(8) 0.148 x 3	1,515	2,680	3,020	3,250	2,305	2,605	2,800	
4½ x 16	MIU4.75/16			•	—	4¾	15 ½	2½	—	(24) 0.162 x 3 ½	(2) 0.148 x 1 ½	210	3,455	3,920	4,045	2,970	3,370	3,480	
	HU3516-2 / HUC3516-2			•	✓	4¾	15 ¼	2½	Max.	(26) 0.162 x 3 ½	(12) 0.148 x 3	1,795	3,870	4,365	4,695	3,330	3,760	4,045	
4½ x 18	MIU4.75/18			•	—	4¾	17 ½	2½	—	(26) 0.162 x 3 ½	(2) 0.148 x 1 ½	210	3,745	4,045	4,045	3,220	3,480	3,480	
	HU3516-2 / HUC3516-2			•	✓	4¾	15 ¼	2½	Max.	(26) 0.162 x 3 ½	(12) 0.148 x 3	1,795	3,870	4,365	4,695	3,330	3,760	4,045	
4½ x 20	MIU4.75/20			•	—	4¾	19 ½	2½	—	(28) 0.162 x 3 ½	(2) 0.148 x 1 ½	210	4,030	4,060	4,060	3,465	3,495	3,495	
	HU3520-2			•	—	4¾	19 ¼	2½	Max.	(26) 0.162 x 3 ½	(12) 0.148 x 3	1,795	3,870	4,365	4,695	3,330	3,760	4,045	
4½ x 21 to 30	MIU4.75/20			•	✓	4¾	19 ½	2½	—	(28) 0.162 x 3 ½	(2) 0.148 x 1 ½	210	4,030	4,060	4,060	3,465	3,495	3,495	
	HU3520-2			•	—	4¾	19 ¼	2½	Max.	(26) 0.162 x 3 ½	(12) 0.148 x 3	1,795	3,870	4,365	4,695	3,330	3,760	4,045	
5 x 9 ½	MIU5.12/9			•	—	5 ½	8 3⁄16	2½	—	(16) 0.162 x 3 ½	(2) 0.148 x 1 ½	210	2,305	2,615	2,820	1,980	2,245	2,425	
	HU310-2 / HUC310-2			•	✓	5 ½	7 3⁄16	2½	—	(14) 0.162 x 3 ½	(6) 0.148 x 3	1,135	2,085	2,350	2,530	1,795	2,025	2,170	
5 x 11 7⁄8	MIU5.12/11			•	—	5 ½	11 ½	2½	—	(20) 0.162 x 3 ½	(2) 0.148 x 1 ½	210	2,880	3,135	3,135	2,475	2,695	2,695	
	HU312-2 / HUC312-2			•	✓	5 ½	10 5⁄8	2½	—	(16) 0.162 x 3 ½	(6) 0.148 x 3	1,135	2,380	2,685	2,890	2,050	2,315	2,490	
5 x 14	MIU5.12/14			•	—	5 ½	13 3⁄16	2½	—	(22) 0.162 x 3 ½	(2) 0.148" x 1 ½	210	3,170	3,595	3,875	2,725	3,090	3,335	
	HU314-2 / HUC314-2			•	✓	5 ½	12 ¾	2½	—	(18) 0.162 x 3 ½	(8) 0.148 x 3	1,515	2,680	3,020	3,250	2,305	2,605	2,800	
5 x 16	MIU5.12/16			•	—	5 ½	15 3⁄16	2½	—	(24) 0.162 x 3 ½	(2) 0.148 x 1 ½	210	3,455	3,920	4,045	2,970	3,370	3,480	
	HU314-2 / HUC314-2			•	✓	5 ½	12 ¾	2½	—	(18) 0.162 x 3 ½	(8) 0.148 x 3	1,515	2,680	3,020	3,250	2,305	2,605	2,800	
5 x 18	MIU5.12/18			•	—	5 ½	17 3⁄16	2½	—	(26) 0.162 x 3 ½	(2) 0.148 x 1 ½	210	3,745	4,045	4,045	3,220	3,480	3,480	
	HU314-2 / HUC314-2			•	✓	5 ½	12 ¾	2½	—	(18) 0.162 x 3 ½	(8) 0.148 x 3	1,515	2,680	3,020	3,250	2,305	2,605	2,800	
5 x 20	MIU5.12/20			•	—	5 ½	19 3⁄16	2½	—	(28) 0.162 x 3 ½	(2) 0.148 x 1 ½	210	4,030	4,060	4,060	3,465	3,495	3,495	
	HU314-2 / HUC314-2			•	✓	5 ½	12 ¾	2½	—	(18) 0.162 x 3 ½	(8) 0.148 x 3	1,515	2,680	3,020	3,250	2,305	2,605	2,800	
5 x 21 to 30	MIU5.12/20			•	✓	5 ½	19 3⁄16	2½	—	(28) 0.162 x 3 ½	(2) 0.148 x 1 ½	210	4,030	4,060	4,060	3,465	3,495	3,495	
5 ½ glulam	HUC05.25/9-SDS	•		—	5 ¼	9	3	—	(12) ¼ x 2 ½ SDS	(6) ¼ x 2 ½ SDS	2,265	4,500	4,500	4,500	3,240	3,240	3,240		
	HUC05.25/11-SDS	•		—	5 ¼	11	3	—	(14) ¼ x 2 ½ SDS	(6) ¼ x 2 ½ SDS	2,265	5,045	5,045	5,045	3,630	3,630	3,630		
	LGU5.25-SDS	•		—	5 ¼	8 to 30	4 ½	—	(16) ¼ x 2 ½ SDS	(12) ¼ x 2 ½ SDS	5,555	6,720	6,720	6,720	4,840	4,840	4,840		
	MGU5.25-SDS	•		—	5 ¼	9 ¼ to 30	4 ½	—	(24) ¼ x 2 ½ SDS	(16) ¼ x 2 ½ SDS	7,260	9,450	9,450	9,450	6,805	6,805	6,805		
	HGU5.25/10	•		—	5 ¼	9 1⁄16	4	—	(46) 0.162 x 3 ½	(16) 0.162 x 3 ½	4,095	9,100	9,100	9,100	7,825	7,825	7,825		
	HGU5.25-SDS	•		—	5 ¼	11 to 30	5 ¼	—	(36) ¼ x 2 ½ SDS	(24) ¼ x 2 ½ SDS	9,460	13,160	13,160	13,160	9,475	9,475	9,475		
	HU5.125/12 / HUC5.125/12	•		—	5 ¼	10 ¼	2 ½	—	(22) 0.162 x 3 ½	(8) 0.162 x 3 ½	1,515	3,275	3,695	3,970	2,820	3,180	3,425		
	HGU5.25/12	•		—	5 ¼	10 5⁄16	4	—	(56) 0.162 x 3 ½	(20) 0.162 x 3 ½	5,205	11,915	13,330	14,290	10,280	12,420	12,420		
	HU5.125/13.5 / HUC5.125/13.5	•		—	5 ¼	13 ¼	2 ½	—	(26) 0.162 x 3 ½	(12) 0.162 x 3 ½	2,695	3,870	4,365	4,695	3,330	3,760	4,045		
	HU5.125/16 / HUC5.125/16	•		—	5 ¼	13 7⁄8	2 ½	—	(26) 0.162 x 3 ½	(12) 0.162 x 3 ½	2,695	3,870	4,365	4,695	3,330	3,760	4,045		
5 ¼ x 7 ¼	HU68 / HUC68			•	—	5 ½	5 3⁄16	2 ½	Min.	(10) 0.162 x 3 ½	(4) 0.148 x 3 ½	760	1,490	1,680	1,805	1,280	1,445	1,555	
				•	—	5 ½	5 3⁄16	2 ½	Max.	(14) 0.162 x 3 ½	(6) 0.148 x 3 ½	1,135	2,085	2,350	2,530	1,795	2,025	2,180	
	HGU5.50/8			•	—	5 ½	6 5⁄16	4	—	(36) 0.162 x 3 ½	(12) 0.162 x 3 ½	3,235	7,460	7,460	7,460	6,415	6,415	6,415	

IBC, FL, LA

© 2021 SIMPSON STRONG-TIE COMPANY, INC.

See footnotes on p. 152.

Face-Mount Hangers — I-Joists, Glulam and SCL

These products are available with additional corrosion protection. For more information, see p. 14.

SS For stainless-steel fasteners, see p. 21.

Codes: See p. 11 for Code Reference Key Chart.

Actual Joist Size (in.)	Model No.	Carried Member			Dimensions (in.)			Min./Max.	Fasteners (in.)		Allowable Loads						Code Ref.	
		Glulam	SCL	I-Joist	Web Stiff Req.	W	H		B	Face	Joist	DF/SP Species Header			SPF/HF Species Header			
												Uplift (160)	Floor (100)	Snow (115)	Roof (125)	Floor (100)		Snow (115)
5¼ x 9½	HU610 / HUC610	•	•	—	5½	7¾	2½	Min.	(14) 0.162 x 3½	(6) 0.162 x 3½	1,345	2,085	2,350	2,530	1,795	2,025	2,180	
	HU610 / HUC610	•	•	—	5½	7¾	2½	Max.	(18) 0.162 x 3½	(8) 0.162 x 3½	1,795	2,680	3,020	3,250	2,305	2,605	2,800	
	HGUS5.50/10	•	—	—	5½	8¼	4	—	(46) 0.162 x 3½	(16) 0.162 x 3½	4,095	9,100	9,100	9,100	7,825	7,825	7,825	
	HHUS5.50/10	•	—	—	5½	9	3	—	(30) 0.162 x 3½	(10) 0.162 x 3½	3,565	5,635	6,380	6,880	4,845	5,490	5,915	
	HUCQ610-SDS	•	—	—	5½	9	3	—	(12) ¼ x 2½ SDS	(6) ¼ x 2½ SDS	2,325	4,680	5,185	5,185	3,370	3,735	3,735	
5¼ x 11¾	MGU5.50-SDS	•	—	—	5½	9¼ to 30	4½	—	(24) ¼ x 2½ SDS	(16) ¼ x 2½ SDS	7,260	9,450	9,450	9,450	6,805	6,805	6,805	
	HHUS5.50/10	•	—	—	5½	9	3	—	(30) 0.162 x 3½	(10) 0.162 x 3½	3,565	5,635	6,380	6,880	4,845	5,490	5,915	
	MGU5.50-SDS	•	—	—	5½	9¼ to 30	4½	—	(24) ¼ x 2½ SDS	(16) ¼ x 2½ SDS	7,260	9,450	9,450	9,450	6,805	6,805	6,805	
	HU612 / HUC612	•	•	—	5½	9%	2½	Min.	(16) 0.162 x 3½	(6) 0.162 x 3½	1,345	2,380	2,685	2,890	2,050	2,315	2,490	
	HU612 / HUC612	•	•	—	5½	9%	2½	Max.	(22) 0.162 x 3½	(8) 0.162 x 3½	1,795	3,275	3,695	3,970	2,820	3,180	3,425	
5¼ x 14	HGUS5.50/12	•	—	—	5½	10½	4	—	(56) 0.162 x 3½	(20) 0.162 x 3½	5,205	11,915	13,330	14,290	10,280	12,420	12,420	
	HUCQ612-SDS	•	—	—	5½	11	3	—	(14) ¼ x 2½ SDS	(6) ¼ x 2½ SDS	2,325	5,185	5,185	5,185	3,735	3,735	3,735	
	HHUS5.50/10	•	—	—	5½	9	3	—	(30) 0.162 x 3½	(10) 0.162 x 3½	3,565	5,635	6,380	6,880	4,845	5,490	5,915	
	MGU5.50-SDS	•	—	—	5½	9¼ to 30	4½	—	(24) ¼ x 2½ SDS	(16) ¼ x 2½ SDS	7,260	9,450	9,450	9,450	6,805	6,805	6,805	
	HUCQ612-SDS	•	—	—	5½	11	3	—	(14) ¼ x 2½ SDS	(6) ¼ x 2½ SDS	2,325	5,185	5,185	5,185	3,735	3,735	3,735	
	HGU5.50-SDS	•	—	—	5½	11 to 30	5¼	—	(36) ¼ x 2½ SDS	(24) ¼ x 2½ SDS	9,460	13,160	13,160	13,160	9,475	9,475	9,475	
	HGU5.50/14	•	—	—	5½	12½	4	—	(66) 0.162 x 3½	(22) 0.162 x 3½	5,360	13,860	14,350	14,350	11,960	12,420	12,420	
5¼ x 16	HU614 / HUC614	•	—	—	5½	11%	2½	Min.	(18) 0.162 x 3½	(8) 0.162 x 3½	1,795	2,975	3,360	3,610	2,565	2,895	3,110	
	HU614 / HUC614	•	—	—	5½	11%	2½	Max.	(24) 0.162 x 3½	(12) 0.162 x 3½	2,695	3,870	4,365	4,695	3,330	3,760	4,045	
	HHGU5.50-SDS	•	—	—	5½	13 to 30	5¼	—	(44) ¼ x 2½ SDS	(28) ¼ x 2½ SDS	14,145	17,345	17,345	17,345	12,490	12,490	12,490	
	HHUS5.50/10	•	—	—	5½	9	3	—	(30) 0.162 x 3½	(10) 0.162 x 3½	3,565	5,635	6,380	6,880	4,845	5,490	5,915	
	MGU5.50-SDS	•	—	—	5½	9¼ to 30	4½	—	(24) ¼ x 2½ SDS	(16) ¼ x 2½ SDS	7,260	9,450	9,450	9,450	6,805	6,805	6,805	
	HUCQ612-SDS	•	—	—	5½	11	3	—	(14) ¼ x 2½ SDS	(6) ¼ x 2½ SDS	2,325	5,185	5,185	5,185	3,735	3,735	3,735	
	HGU5.50-SDS	•	—	—	5½	11 to 30	5¼	—	(36) ¼ x 2½ SDS	(24) ¼ x 2½ SDS	9,460	13,160	13,160	13,160	9,475	9,475	9,475	
5¼ x 18	HGU5.50/14	•	—	—	5½	12½	4	—	(66) 0.162 x 3½	(22) 0.162 x 3½	5,360	13,860	14,350	14,350	11,960	12,420	12,420	
	HU616 / HUC616	•	—	—	5½	13%	2½	Min.	(20) 0.162 x 3½	(8) 0.162 x 3½	1,795	2,975	3,360	3,610	2,565	2,895	3,110	
	HU616 / HUC616	•	—	—	5½	13%	2½	Max.	(26) 0.162 x 3½	(12) 0.162 x 3½	2,695	3,870	4,365	4,695	3,330	3,760	4,045	
	HHGU5.50-SDS	•	—	—	5½	13 to 30	5¼	—	(44) ¼ x 2½ SDS	(28) ¼ x 2½ SDS	14,145	17,345	17,345	17,345	12,490	12,490	12,490	
	HUCQ612-SDS	•	—	—	5½	11	3	—	(14) ¼ x 2½ SDS	(6) ¼ x 2½ SDS	2,325	5,185	5,185	5,185	3,735	3,735	3,735	
	HGU5.50/14	•	—	—	5½	12½	4	—	(66) 0.162 x 3½	(22) 0.162 x 3½	5,360	13,860	14,350	14,350	11,960	12,420	12,420	
	HU616 / HUC616	•	—	—	5½	12¼	2½	Min.	(20) 0.162 x 3½	(8) 0.162 x 3½	1,795	2,975	3,360	3,610	2,565	2,895	3,110	
5¼ x 20 to 30	HU616 / HUC616	•	—	—	5½	12¼	2½	Max.	(26) 0.162 x 3½	(12) 0.162 x 3½	2,695	3,870	4,365	4,695	3,330	3,760	4,045	
	HGU5.50-SDS	•	—	—	5½	16 to 17¾	5¼	—	(36) ¼ x 2½ SDS	(24) ¼ x 2½ SDS	9,460	13,160	13,160	13,160	9,475	9,475	9,475	
	MGU5.50-SDS	•	—	—	5½	16 to 17¾	4½	—	(24) ¼ x 2½ SDS	(16) ¼ x 2½ SDS	7,260	9,450	9,450	9,450	6,805	6,805	6,805	
	HHGU5.50-SDS	•	—	—	5½	16 to 17¾	5¼	—	(44) ¼ x 2½ SDS	(28) ¼ x 2½ SDS	14,145	17,345	17,345	17,345	12,490	12,490	12,490	
	MGU5.50-SDS	•	—	—	5½	18 to 30	4½	—	(24) ¼ x 2½ SDS	(16) ¼ x 2½ SDS	7,260	9,450	9,450	9,450	6,805	6,805	6,805	
	HGU5.50-SDS	•	—	—	5½	18 to 30	5¼	—	(36) ¼ x 2½ SDS	(24) ¼ x 2½ SDS	9,460	13,160	13,160	13,160	9,475	9,475	9,475	
	HHGU5.50-SDS	•	—	—	5½	18 to 30	5¼	—	(44) ¼ x 2½ SDS	(28) ¼ x 2½ SDS	14,145	17,345	17,345	17,345	12,490	12,490	12,490	
5½ glulam	HU610 / HUC610	•	—	—	5½	7¾	2½	Max.	(18) 0.162 x 3½	(8) 0.162 x 3½	1,795	2,680	3,020	3,250	2,305	2,605	2,800	
	HGUS5.50/10	•	—	—	5½	8¼	4	—	(46) 0.162 x 3½	(16) 0.162 x 3½	4,095	9,100	9,100	9,100	7,825	7,825	7,825	
	HUCQ610-SDS	•	—	—	5½	9	3	—	(12) ¼ x 2½ SDS	(6) ¼ x 2½ SDS	2,325	4,680	5,185	5,185	3,370	3,735	3,735	
	HHUS5.50/10	•	—	—	5½	9	3	—	(30) 0.162 x 3½	(10) 0.162 x 3½	3,565	5,635	6,380	6,880	4,845	5,490	5,915	
	MGU5.62-SDS	•	—	—	5½	9¼ to 30	4½	—	(24) ¼ x 2½ SDS	(16) ¼ x 2½ SDS	7,260	9,450	9,450	9,450	6,805	6,805	6,805	
	HU612 / HUC612	•	—	—	5½	9%	2½	Max.	(22) 0.162 x 3½	(8) 0.162 x 3½	1,795	3,275	3,695	3,970	2,820	3,180	3,425	
	HUCQ612-SDS	•	—	—	5½	11	3	—	(14) ¼ x 2½ SDS	(6) ¼ x 2½ SDS	2,325	5,185	5,185	5,185	3,735	3,735	3,735	
	HGU5.62-SDS	•	—	—	5½	11 to 30	5¼	—	(36) ¼ x 2½ SDS	(24) ¼ x 2½ SDS	5,360	13,735	14,360	14,360	11,810	12,350	12,350	
	HGU5.50/14	•	—	—	5½	12½	4	—	(66) 0.162 x 3½	(22) 0.162 x 3½	5,515	13,860	14,350	14,350	11,960	12,420	12,420	
	HU616 / HUC616	•	—	—	5½	13%	2½	Max.	(26) 0.162 x 3½	(12) 0.162 x 3½	2,695	3,870	4,365	4,695	3,330	3,760	4,045	
HHGU5.62-SDS	•	—	—	5½	13 to 30	5¼	—	(44) ¼ x 2½ SDS	(28) ¼ x 2½ SDS	14,145	17,345	17,345	17,345	12,490	12,490	12,490		

I-Joist, Glulam and Structural Composite Lumber Connectors

IBC, FL, LA

See footnotes on p. 152.

Face-Mount Hangers — I-Joists, Glulam and SCL

Codes: See p. 11 for Code Reference Key Chart.

I-Joist, Glulam and Structural Composite Lumber Connectors

Actual Joist Size (in.)	Model No.	Carried Member			Dimensions (in.)			Min./Max.	Fasteners (in.)		Allowable Loads						Code Ref.	
		Glulam	SCL	I-Joist	Web Stiff Req.	W	H		B	Face	Joist	DF/SP Species Header			SPF/HF Species Header			
												Uplift (160)	Floor (100)	Snow (115)	Roof (125)	Floor (100)		Snow (115)
6¾ glulam	HGUS6.88/10	•		—	6⅞	8⅞	4	—	(46) 0.162 x 3½	(16) 0.162 x 3½	4,095	9,100	9,100	9,100	7,825	7,825	7,825	
	MGU7.00-SDS	•		—	7	9¼ to 30	4½	—	(24) ¼ x 2½ SDS	(16) ¼ x 2½ SDS	7,260	9,450	9,450	9,450	6,805	6,805	6,805	
	HGUS6.88/12	•		—	6⅞	10⅞	4	—	(56) 0.162 x 3½	(20) 0.162 x 3½	5,205	11,915	13,330	14,290	10,280	12,420	12,420	
	HGUS6.88/14	•		—	6⅞	12⅞	4	—	(66) 0.162 x 3½	(22) 0.162 x 3½	5,360	13,860	14,350	14,350	11,960	12,420	12,420	
	HGU7.00-SDS	•		—	7	11 to 30	5¼	—	(36) ¼ x 2½ SDS	(24) ¼ x 2½ SDS	9,460	13,160	13,160	13,160	9,475	9,475	9,475	
	HHGU7.00-SDS	•		—	7	13 to 30	5¼	—	(44) ¼ x 2½ SDS	(28) ¼ x 2½ SDS	14,145	17,345	17,345	17,345	12,490	12,490	12,490	
7 x 9½	HGUS7.25/10	•	•	—	7¼	8⅞	4	—	(46) 0.162 x 3½	(16) 0.162 x 3½	4,095	9,100	9,100	9,100	7,825	7,825	7,825	
	HU410-2 / HUC410-2	•	•	•	7⅞	8⅞	2½	Max.	(18) 0.162 x 3½	(8) 0.162 x 3½	1,795	2,680	3,020	3,250	2,305	2,605	2,800	
	HHUS7.25/10	•	•	—	7¼	9	3⅞	—	(30) 0.162 x 3½	(10) 0.162 x 3½	3,565	5,635	6,380	6,880	4,845	5,490	5,915	
7 x 11⅞	HHUS7.25/10	•	•	—	7¼	9	3⅞	—	(30) 0.162 x 3½	(10) 0.162 x 3½	3,565	5,635	6,380	6,880	4,845	5,490	5,915	
	HGUS7.25/12	•	•	—	7¼	10⅞	4	—	(56) 0.162 x 3½	(20) 0.162 x 3½	5,205	11,915	13,330	14,290	10,280	12,420	12,420	
	HU412-2 / HUC412-2	•	•	•	✓	7⅞	10⅞	2½	Max.	(22) 0.162 x 3½	(8) 0.162 x 3½	1,795	3,275	3,695	3,970	2,820	3,180	3,425
	HGU7.25-SDS	•		—	7¼	11 to 30	5¼	—	(36) ¼ x 2½ SDS	(24) ¼ x 2½ SDS	9,460	13,160	13,160	13,160	9,475	9,475	9,475	
7 x 14	HHUS7.25/10	•	•	—	7¼	9	3⅞	—	(30) 0.162 x 3½	(10) 0.162 x 3½	3,565	5,635	6,380	6,880	4,845	5,490	5,915	
	HGUS7.25/14	•	•	—	7¼	12⅞	4	—	(66) 0.162 x 3½	(22) 0.162 x 3½	5,360	13,860	14,350	14,350	11,960	12,420	12,420	
	HGU7.25-SDS	•	•	—	7¼	11 to 13⅞	5¼	—	(36) ¼ x 2½ SDS	(24) ¼ x 2½ SDS	9,460	13,160	13,160	13,160	9,475	9,475	9,475	
	HHGU7.25-SDS	•	•	—	7¼	13 to 13⅞	5¼	—	(44) ¼ x 2½ SDS	(28) ¼ x 2½ SDS	14,145	17,345	17,345	17,345	12,490	12,490	12,490	
	HU414-2 / HUC414-2	•	•	•	✓	7⅞	12⅞	2½	Max.	(26) 0.162 x 3½	(12) 0.162 x 3½	2,695	3,870	4,365	4,695	3,330	3,760	4,045
7 x 16	HGUS7.25/14	•	•	—	7¼	12⅞	4	—	(66) 0.162 x 3½	(22) 0.162 x 3½	5,360	13,860	14,350	14,350	11,960	12,420	12,420	
	HGU7.25-SDS	•	•	—	7¼	11 to 15⅞	5¼	—	(36) ¼ x 2½ SDS	(24) ¼ x 2½ SDS	9,460	13,160	13,160	13,160	9,475	9,475	9,475	
	HHGU7.25-SDS	•	•	—	7¼	13 to 15⅞	5¼	—	(44) ¼ x 2½ SDS	(28) ¼ x 2½ SDS	14,145	17,345	17,345	17,345	12,490	12,490	12,490	
	HU414-2 / HUC414-2	•	•	•	✓	7⅞	12⅞	2½	Max.	(26) 0.162 x 3½	(12) 0.162 x 3½	2,695	3,870	4,365	4,695	3,330	3,760	4,045
7 x 18	HGUS7.25/14	•	•	—	7¼	12⅞	4	—	(66) 0.162 x 3½	(22) 0.162 x 3½	5,360	13,860	14,350	14,350	11,960	12,420	12,420	
	HGU7.25-SDS	•	•	—	7¼	11 to 17⅞	5¼	—	(36) ¼ x 2½ SDS	(24) ¼ x 2½ SDS	9,460	13,160	13,160	13,160	9,475	9,475	9,475	
	HHGU7.25-SDS	•	•	—	7¼	13 to 17⅞	5¼	—	(44) ¼ x 2½ SDS	(28) ¼ x 2½ SDS	14,145	17,345	17,345	17,345	12,490	12,490	12,490	
	HU414-2 / HUC414-2	•	•	•	✓	7⅞	13⅞	2½	Max.	(26) 0.162 x 3½	(12) 0.162 x 3½	2,695	3,870	4,365	4,695	3,330	3,760	4,045
7 x 20 to 30	HGU7.25-SDS	•	•	—	7¼	11 to 30	5¼	—	(36) ¼ x 2½ SDS	(24) ¼ x 2½ SDS	9,460	13,160	13,160	13,160	9,475	9,475	9,475	
	HHGU7.25-SDS	•	•	—	7¼	13 to 30	5¼	—	(44) ¼ x 2½ SDS	(28) ¼ x 2½ SDS	14,145	17,345	17,345	17,345	12,490	12,490	12,490	
8¾ glulam	HGU9.00-SDS	•		—	9	11 to 30	5¼	—	(36) ¼ x 2½ SDS	(24) ¼ x 2½ SDS	9,460	13,160	13,160	13,160	9,475	9,475	9,475	
	HHGU9.00-SDS	•		—	9	13 to 30	5¼	—	(44) ¼ x 2½ SDS	(28) ¼ x 2½ SDS	14,145	17,345	17,345	17,345	12,490	12,490	12,490	
10¾ glulam	HHGU11.00-SDS	•		—	11	13 to 30	5¼	—	(44) ¼ x 2½ SDS	(28) ¼ x 2½ SDS	14,145	17,345	17,345	17,345	12,490	12,490	12,490	

IBC, FL, LA

- Uplift loads have been increased for earthquake or wind loading with no further increase allowed. Reduce where other loads govern.
- Uplift loads are based on DF/SP. For SPF/HF, use 0.86 x DF/SP Uplift Load for products requiring nails and 0.72 x DF/SP Uplift Load for products requiring screws.
- For minimum nailing quantity and load values, fill all round holes; for maximum nailing quantity and load values, fill all round and triangular holes.
- Hangers sorted in order of recommended selection for best overall performance and installation value.
- Web stiffeners are required where noted in the table, or when the joist top flange isn't supported laterally by the hanger, or when it supports double I-joists with flanges less than 1⅞" thick.
- Allowable downloads are based on a joist-bearing capacity of 750 psi.
- Fasteners:** Nail dimensions are diameter by length. SDS screws are Simpson Strong-Tie® Strong-Drive® SDS Heavy-Duty Connector screws. See pp. 21–22 for fastener information.