

PB/PBS

Regular and Standoff Post Bases

The PBS features a 1" standoff height. It reduces the potential for decay at post and column ends.

Material: PB — 12 gauge; PBS — see table

Finish: Galvanized. Some products available in ZMAX® or HDG coating; see Corrosion Information, pp. 12–15.

Installation:

- Use all specified fasteners; see General Notes.
- Install either nails or bolts.
- Post bases do not provide adequate resistance to prevent members from rotating about the base and therefore are not recommended for non-top-supported installations (such as fences or unbraced carports).
- PB — Holes are provided for installation with either 0.162" x 3 1/2" nails or 1/2" bolts for PB66 and PB66R; all other models use 0.162" x 3 1/2" nails only. A 2" minimum sidecover is required to obtain the full load.
- PBS — Embed into wet concrete up to the bottom of the 1" standoff base plate. A 2" minimum side cover is required to obtain the full load. Holes in the bottom of the straps allow for free concrete flow.

Codes: See p. 11 for Code Reference Key Chart

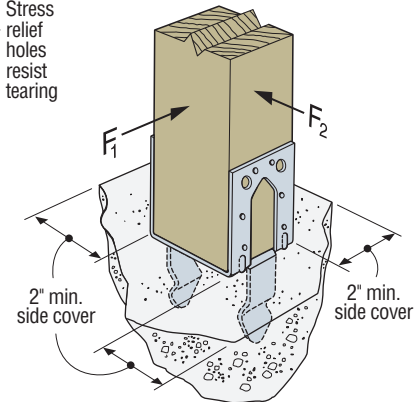
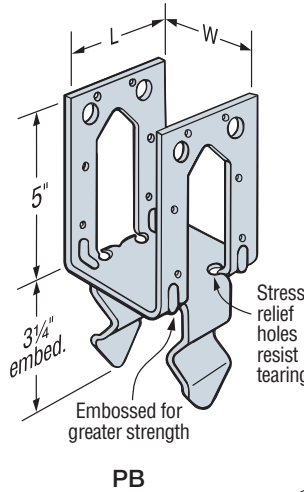

Typical PB Installation

These products are available with additional corrosion protection. For more information, see p. 14.

Model No.	Dimensions (in.)		Fasteners		Allowable Loads (160)		Download (100)	Code Ref.
	W	L	Nails (in.)	Machine Bolts	Uncracked Uplift	Cracked Uplift		
Wind and Seismic Design Category A&B								
PB44	3 3/16	3 3/4	(12) 0.162 x 3 1/2	N/A	850	850	12,685	IBC, FL, LA
PB44R	4	3 3/4	(12) 0.162 x 3 1/2	N/A	850	850	12,685	
PB46	5 1/2	3 3/4	(12) 0.162 x 3 1/2	N/A	850	850	22,445	
PB66	5 1/2	5 1/4	(12) 0.162 x 3 1/2	(2) 1/2" dia.	850	850	25,270	
PB66R	6	5 1/4	(12) 0.162 x 3 1/2	(2) 1/2" dia.	850	850	25,270	
Seismic Design Category C-F								
PB44	3 3/16	3 3/4	(12) 0.162 x 3 1/2	N/A	850	850	12,685	IBC, FL, LA
PB44R	4	3 3/4	(12) 0.162 x 3 1/2	N/A	850	850	12,685	
PB46	5 1/2	3 3/4	(12) 0.162 x 3 1/2	N/A	850	850	22,445	
PB66	5 1/2	5 1/4	(12) 0.162 x 3 1/2	(2) 1/2" dia.	850	850	25,270	
PB66R	6	5 1/4	(12) 0.162 x 3 1/2	(2) 1/2" dia.	850	850	25,270	

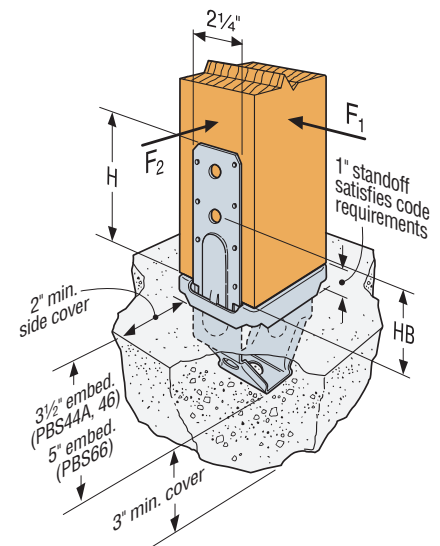

Typical PBS44A Installation

1. Loads may not be increased for duration of load.
2. Concrete shall have a minimum compressive strength of $f'_c = 2,500$ psi.
3. Multiply Seismic and Wind ASD uplift and lateral load values by 1.43 or 1.67, respectively, to obtain LRFD capacities.
4. In accordance with IBC, Section 1613.1, detached one- and two-family dwellings in Seismic Design Category (SDC) C may use "Wind and SDC A&B" allowable loads.
5. Downloads shall be reduced where limited by capacity of the post.
6. For lateral loads for all PB models: F_1 allowable = 765 lb. F_2 allowable = 1,325 lb.
7. Designer is responsible for concrete design.
8. Structural composite lumber columns have sides that show either the wide face or the edges of the lumber strands/veneers known as the narrow face. Values in the tables reflect installation into the wide face. See technical bulletin T-C-SCLCLM at strongtie.com for load reductions resulting from narrow-face installations.
9. **Fasteners:** Nail dimensions are listed diameter by length. See pp. 21–22 for fastener information.

PB/PBS

Regular and Standoff Post Bases (cont.)

These products are available with additional corrosion protection. For more information, see p. 14.

SD Many of these products are approved for installation with Strong-Drive® SD Connector screws. See pp. 348–352 for more information.

Model No.	Nominal Post Size	Material (ga.)		Dimensions (in.)				Fasteners (in.)		Allowable Loads			Code Ref.
		Base	Strap	W	L	H	HB	Nails	Machine Bolts	Uncracked Uplift	Cracked Uplift	Download	
Wind and Seismic Design Category A&B													
PBS44A	4x4	12	14	3 ⁹ / ₁₆	3 ¹ / ₂	6 ¹ / ₄	3 ⁷ / ₁₆	(14) 0.162 x 3 ¹ / ₂	(2) ½ dia.	1,235	865	6,665	IBC, FL, LA
PBS46	4x6	12	14	3 ⁹ / ₁₆	5 ⁷ / ₁₆	6 ⁹ / ₁₆	3 ³ / ₈	(14) 0.162 x 3 ¹ / ₂	(2) ½ dia.	1,235	865	9,335	
PBS66	6x6	12	12	5 ¹ / ₂	5 ³ / ₈	6 ¹ / ₂	3 ¹ / ₁₆	(14) 0.162 x 3 ¹ / ₂	(2) ½ dia.	2,165	2,165	9,335	
Seismic Design Category C–F													
PBS44A	4x4	12	14	3 ⁹ / ₁₆	3 ¹ / ₂	6 ¹ / ₄	3 ⁷ / ₁₆	(14) 0.162 x 3 ¹ / ₂	(2) ½ dia.	1,080	755	6,665	IBC, FL, LA
PBS46	4x6	12	14	3 ⁹ / ₁₆	5 ⁷ / ₁₆	6 ⁹ / ₁₆	3 ³ / ₈	(14) 0.162 x 3 ¹ / ₂	(2) ½ dia.	1,080	755	9,335	
PBS66	6x6	12	12	5 ¹ / ₂	5 ³ / ₈	6 ¹ / ₂	3 ¹ / ₁₆	(14) 0.162 x 3 ¹ / ₂	(2) ½ dia.	2,165	2,165	9,335	

- For higher downloads, pack grout solid under 1" standoff plate before installation. Base download on column or concrete, according to the code.
- Concrete shall have a minimum compressive strength of $f'_c = 2,500$ psi.
- Multiply Seismic and Wind ASD uplift and lateral load values by 1.43 or 1.67, respectively, to obtain LRFD capacities.
- In accordance with IBC, Section 1613.1, detached one- and two-family dwellings in Seismic Design Category (SDC) C may use "Wind and SDC A&B" allowable loads.
- Post bases do not provide adequate resistance to prevent members from rotating about the base and therefore are not recommended for installations that lack top support (such as fences or unbraced carports).
- Downloads shall be reduced where limited by capacity of the post.
- Designer is responsible for concrete design.
- For lateral loads for all PBS models: F_1 allowable = 1,165 lb. when using nails and 230 lb. when using bolts. F_2 allowable = 835 lb. when using either nails or bolts.
- Structural composite lumber columns have sides that show either the wide face or the edges of the lumber strands/veneers known as the narrow face. Values in the tables reflect installation into the wide face. See technical bulletin T-C-SCLCLM at strongtie.com for load reductions resulting from narrow-face installations.
- Fasteners:** Nail dimensions are listed diameter by length. See pp. 21–22 for fastener information.