

# RCA Rigid Connector Angles

The Simpson Strong-Tie® rigid connector angle is a general-purpose clip angle designed for a wide range of cold-formed steel construction applications. With prepunched holes for fastener attachment, these L-shaped clips save time and labor on the job.

### Features:

- Use with miscellaneous header/sill connections to jamb studs, jamb stud reinforcement at track, u-channel bridging, stud-blocking, bypass curtain-wall framing and more
- Easy to install, with prepunched holes for quick and accurate fastener attachment

**Material:** RCA223/54, RCA225/54, RCA227/54, RCA333/54, RCA335/54 — 54 mil (16 ga.), 50 ksi;

RCA223/68, RCA225/68, RCA227/68, RCA333/68, RCA335/68 — 68 mil (14 ga.), 50 ksi;

RCA223/97, RCA225/97, RCA227/97, RCA333/97, RCA335/97 — 97 mil (12 ga.), 50 ksi

**Finish:** Galvanized (G90)

### Installation:

- Use all specified anchors/fasteners

## Ordering Information

Model No.	Ordering SKU	Bucket Quantity
RCA223/54	RCA223/54-R150	150
RCA223/68	RCA223/68-R125	125
RCA223/97	RCA223/97-R90	90
RCA225/54	RCA225/54-R90	90
RCA225/68	RCA225/68-R75	75
RCA225/97	RCA225/97-R55	55
RCA227/54	RCA227/54-R65	65
RCA227/68	RCA227/68-R55	55
RCA227/97	RCA227/97-R40	40
RCA333/54	RCA333/54-R100	100
RCA333/68	RCA333/68-R85	85
RCA333/97	RCA333/97-R60	60
RCA335/54	RCA335/54-R60	60
RCA335/68	RCA335/68-R50	50
RCA335/97	RCA335/97-R35	35

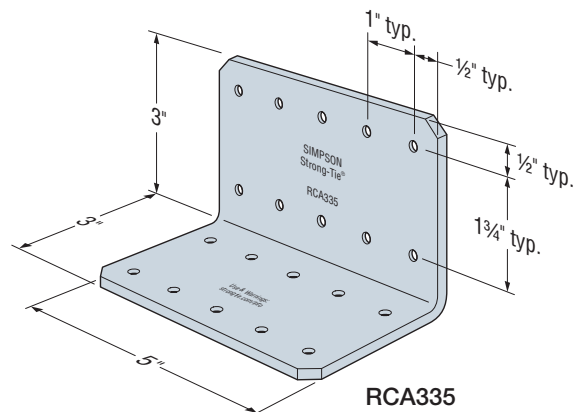
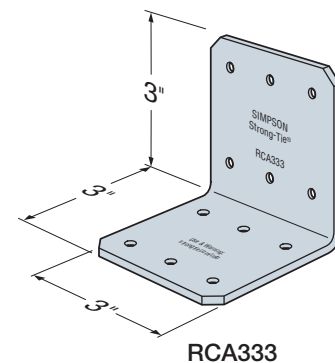
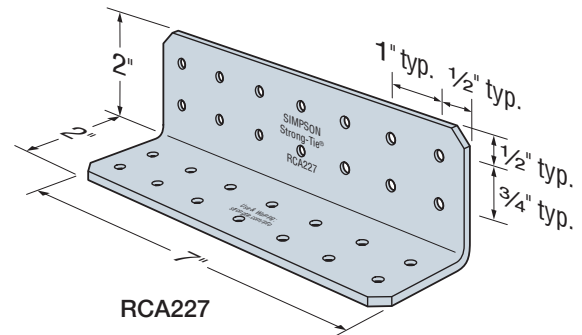
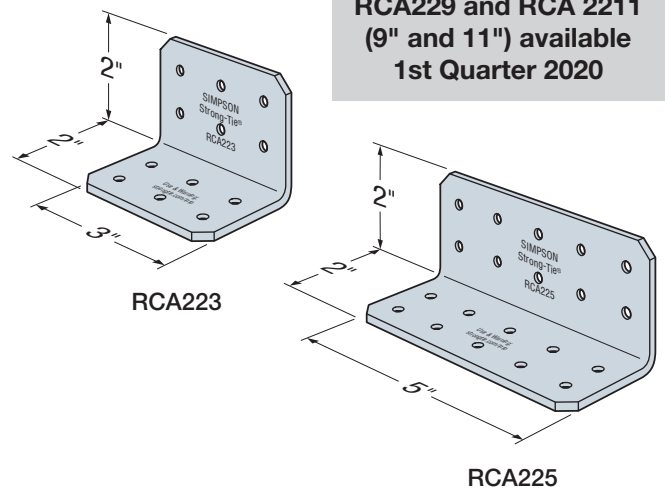

# RCA Rigid Connector Angles

Rigid Connectors

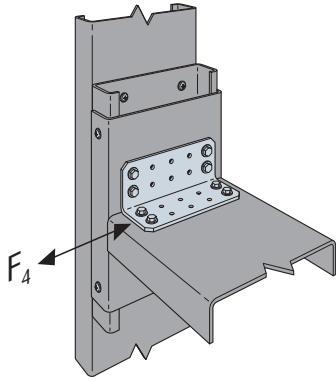

Typical RCA225 Installation at Sill/Jamb

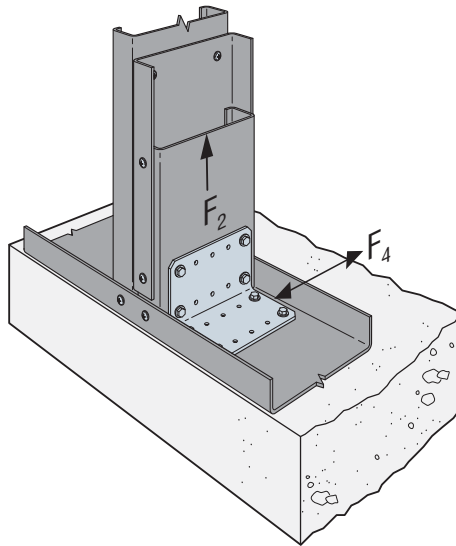

Typical RCA335 Installation at Base of Jamb

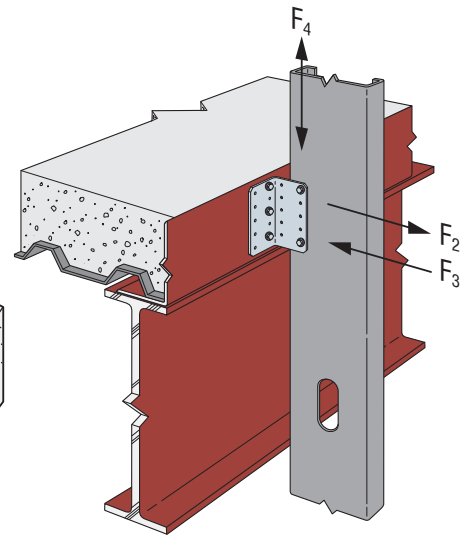

Typical RCA335 Installation at Bypass Framing

## Screw Patterns for Rigid Connector Angles

Models	Pattern 1	Pattern 2	Pattern 3	Pattern 4	Pattern 5	Pattern 6	Pattern 7	Pattern 8
RCA223/54 RCA223/68 RCA223/97 RCA333/54 RCA333/68 RCA333/97								
RCA225/54 RCA225/68 RCA225/97 RCA335/54 RCA335/68 RCA335/97								
RCA227/54 RCA227/68 RCA227/97								

## RCA Rigid Connector Angles

## RCA Rigid Connector Angles Allowable Loads (lb.)

Model	No. of #10 Screws <sup>5,6</sup>	Screw Pattern	Stud Framing Thickness <sup>11</sup>								
			33 mil (20 ga.)			43 mil (18 ga.)			54 mil (16 ga.)		
			F <sub>2</sub>	F <sub>3</sub>	F <sub>4</sub>	F <sub>2</sub>	F <sub>3</sub>	F <sub>4</sub>	F <sub>2</sub>	F <sub>3</sub>	F <sub>4</sub>
RCA223/54	3	1	205	495	200	205	590	310	205	590	620
	4	2	205	580	390	205	580	605	205	580	1,095
	6	3	205	865	480	205	865	740	205	865	1,095
RCA223/68	3	1	310	495	200	310	765	310	310	815	620
	4	2	310	660	390	310	805	605	310	805	1,210
	6	3	310	990	480	310	1,205	740	310	1,205	1,350
RCA223/97	3	1	495	495	200	630	765	310	630	1,415	620
	4	2	630	660	390	630	1,020	605	630	1,265	1,210
	6	3	630	990	480	630	1,530	740	630	1,895	1,485
RCA225/54	2	4	330	330	265	340	390	410	340	390	815
	4	5	340	580	535	340	580	830	340	580	1,660
	5	6	340	825	460	340	980	705	340	980	1,310
	8	7	340	1,155	915	340	1,155	1,420	340	1,155	1,825
	10	8	340	1,445	1,035	340	1,445	1,600	340	1,445	1,825
RCA225/68	2	4	330	330	265	510	510	410	520	545	815
	4	5	520	660	535	520	805	830	520	805	1,660
	5	6	520	825	460	520	1,275	705	520	1,360	1,415
	8	7	520	1,320	915	520	1,605	1,420	520	1,605	2,255
	10	8	520	1,650	1,035	520	2,010	1,600	520	2,010	2,255
RCA225/97	2	4	330	330	265	510	510	410	1,020	945	815
	4	5	660	660	535	1,020	1,020	830	1,050	1,265	1,660
	5	6	825	825	460	1,050	1,275	705	1,050	2,360	1,415
	8	7	1,050	1,320	915	1,050	2,040	1,420	1,050	2,525	2,835
	10	8	1,050	1,650	1,035	1,050	2,550	1,600	1,050	3,155	3,200
RCA227/54	4	9	475	660	545	475	785	840	475	785	1,675
	4	10	475	580	595	475	580	920	475	580	1,840
	7	11	475	1,155	765	475	1,280	1,185	475	1,280	1,685
	8	12	475	1,155	1,120	475	1,155	1,730	475	1,155	2,555
	14	13	475	2,025	1,685	475	2,025	2,555	475	2,025	2,555
RCA227/68	4	9	660	660	545	725	1,020	840	725	1,090	1,675
	4	10	660	660	595	725	805	920	725	805	1,840
	7	11	725	1,155	765	725	1,780	1,185	725	1,780	2,370
	8	12	725	1,320	1,120	725	1,605	1,730	725	1,605	3,155
	14	13	725	2,310	1,685	725	2,810	2,605	725	2,810	3,155
RCA227/97	4	9	660	660	545	1,020	1,020	840	1,470	1,890	1,675
	4	10	660	660	595	1,020	1,020	920	1,470	1,265	1,840
	7	11	1,155	1,155	765	1,470	1,785	1,185	1,470	3,080	2,370
	8	12	1,320	1,320	1,120	1,470	2,040	1,730	1,470	2,525	3,460
	14	13	1,470	2,310	1,685	1,470	3,570	2,605	1,470	4,420	4,490

See footnotes on p. 96.

# RCA Rigid Connector Angles

## RCA Rigid Connector Angles Allowable Loads (lb.)

Model	No. of #10 Screws <sup>5,6</sup>	Screw Pattern	Stud Framing Thickness <sup>11</sup>								
			33 mil (20 ga.)			43 mil (18 ga.)			54 mil (16 ga.)		
			F <sub>2</sub>	F <sub>3</sub>	F <sub>4</sub>	F <sub>2</sub>	F <sub>3</sub>	F <sub>4</sub>	F <sub>2</sub>	F <sub>3</sub>	F <sub>4</sub>
RCA333/54	3	1	205	440	130	205	440	195	205	440	395
	4	2	205	580	325	205	580	505	205	580	1,005
	6	3	205	865	430	205	865	665	205	865	1,095
RCA333/68	3	1	310	495	130	310	615	195	310	615	395
	4	2	310	660	325	310	805	505	310	805	1,005
	6	3	310	990	430	310	1,205	665	310	1,205	1,335
RCA333/97	3	1	495	495	130	630	765	195	630	1,065	395
	4	2	630	660	325	630	1,020	505	630	1,265	1,005
	6	3	630	990	430	630	1,530	665	630	1,895	1,335
RCA335/54	2	4	330	295	205	340	295	320	340	295	635
	4	5	340	580	450	340	580	695	340	580	1,390
	5	6	340	735	305	340	735	475	340	735	835
	8	7	340	1,155	755	340	1,155	1,170	340	1,155	1,825
	10	8	340	1,445	860	340	1,445	1,330	340	1,445	1,825
RCA335/68	2	4	330	330	205	510	410	320	520	410	635
	4	5	520	660	450	520	805	695	520	805	1,390
	5	6	520	825	305	520	1,025	475	520	1,025	945
	8	7	520	1,320	755	520	1,605	1,170	520	1,605	2,255
	10	8	520	1,650	860	520	2,010	1,330	520	2,010	2,255
RCA335/97	2	4	330	330	205	510	510	320	1,020	710	635
	4	5	660	660	450	1,020	1,020	695	1,050	1,265	1,390
	5	6	825	825	305	1,050	1,275	475	1,050	1,775	945
	8	7	1,050	1,320	755	1,050	2,040	1,170	1,050	2,525	2,335
	10	8	1,050	1,650	860	1,050	2,550	1,330	1,050	3,155	2,660

- As applicable, the tabulated values are calculated based on AISI RP15-2, AISI S100 or generally accepted industry standards.
- The tabulated values do not account for anchorage to the support. Anchor strength must be calculated separately and may reduce the capacity of the connection when compared to the tabulated values.
- Tabulated values do not include shear, web crippling, buckling or other local effects in the member. The designer must check member limit states separately.
- For load combinations that include F<sub>4</sub> and/or F<sub>2</sub> and/or F<sub>3</sub>, use an appropriate interaction equation.
- #10–16 screws shall have P<sub>SS</sub> ≥ 1,620 lb. Calculated values are per AISI S100. Screws must be installed with three (minimum) exposed threads.
- The number of screws is for one clip leg that is attached to the supported stud.
- In addition to calculations of net and gross section tension, F<sub>2</sub> values are also calculated and normally controlled by weak-axis bending of the anchored clip leg with the line of bending at the holes nearest the bend radius of the angle. The designer is responsible for calculating pullover, pullout and tension strength of the anchors and this may reduce F<sub>2</sub> strength compared to the tabulated values.
- F<sub>3</sub> strength values are computed using the plate buckling provisions of AISI RP15-2.
- For the F<sub>4</sub> strength values it's assumed that all of the connection eccentricity is taken by the screws in the supported stud. F<sub>4</sub> values are also limited by plate shear buckling per AISI RP15-2. The designer is responsible for calculating the shear capacity of the anchorage, which may reduce F<sub>4</sub> strength compared to the tabulated values.
- In addition to the limit states given in notes 7, 8 and 9, F<sub>2</sub>, F<sub>3</sub> and F<sub>4</sub> are also limited by screw shear according to the thinnest connected part of the connector and stud.
- For 50 ksi studs, 68 mil (14 ga.) and thicker, use the tabulated values for 54 mil (16 ga.) — 50 ksi studs.