

S/HDS and S/HDB Holdowns

The S/HD series of holdowns is designed for installation with either screws or bolts into the studs or column. The S/HDS series installs with #14 screws and has been designed to utilize fewer fasteners to reduce installation time. The S/HDB series is ideal for bolt-on applications where the cold-formed stud manufacturer can prepunch the bolt holes.

Material: See table

Finish: Simpson Strong-Tie® gray paint. Hot-dip galvanized is available; see Corrosion-Information, pp. 17–19.

Installation:

- Use all specified fasteners; some models have extra fastener holes. See General Notes.
- Anchor bolt washer is not required.
- Standard washers are required on stud bolt nuts for model S/HDB.
- Thin wall socket (OD = 2" maximum) is required for S/HD15 to tighten the 1" anchor bolt.
- Stud bolts — use A307.
- Boundary members (back-to-back studs) design shall be by designer.
- S/HDS and S/HDB holdowns can be welded per designer's recommendation and specification. To tie back-to-back stud members together, the designer must determine the fasteners required to bind members to act as one unit. Welders and welding procedures shall be qualified as specified in AWS D1.3. Welded connections used for cold-formed steel structural members in which the thickness of the thinnest connected part is 0.18 inch or less shall comply to AISI S100 Specification Section E2.
- See SB, SSTB and PAB Anchor Bolts on pp. 163–164 for anchorage options.
- See SET-XP® and AT-XP® adhesive products at strongtie.com for anchor bolt retrofit options.

Codes: See p. 11 for Code Reference Key Chart

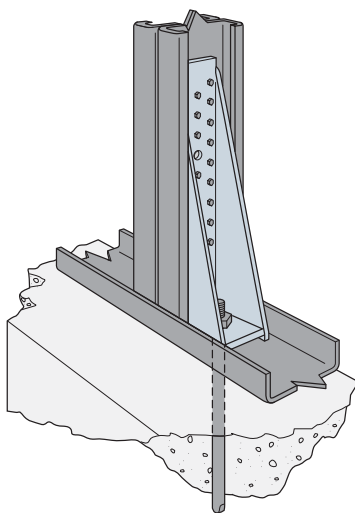
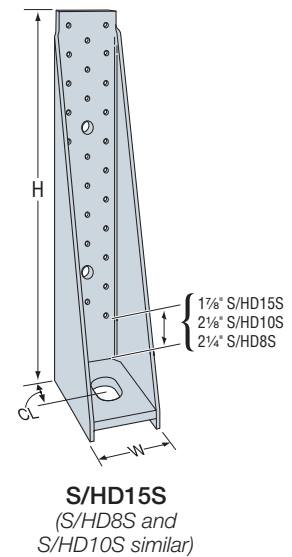
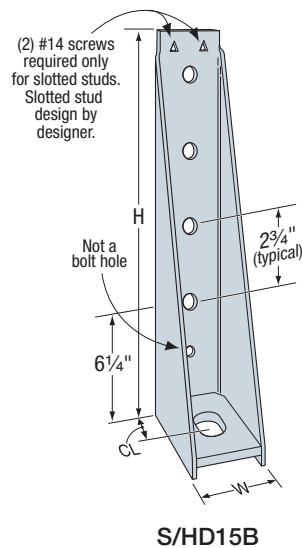

Typical S/HD10S
Back-to-Back Stud
Installation

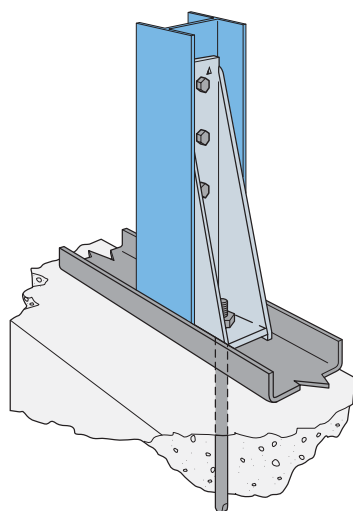

Typical S/HD10B
PACO Column Installation
See Code Report

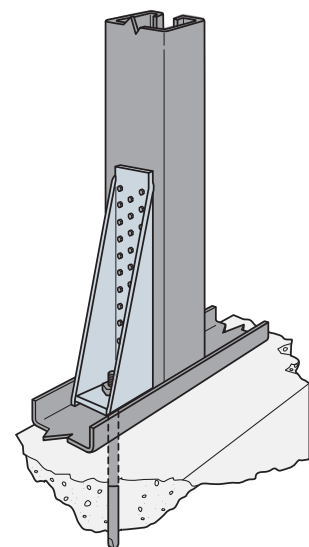

Typical S/HD10S Heavy-Duty
(Large Flange) Stud Application
See Code Report

S/HDS and S/HDB Holdowns

Model No.	Mil (ga.)	H (in.)	W (in.)	C (in.)	Fasteners		Stud Member Thickness mil (ga.)	ASD (lb.)		LRFD (lb.)		Nominal Tension Load (lb.)	Code Ref.
					Anchor Bolt Dia. ¹ (in.)	Stud Fasteners ⁷		Tension Load	Deflection at ASD Load ⁴	Tension Load	Deflection at LRFD Load ⁴		
S/HD8S	118 (10)	11	2 ⁵ / ₁₆	1 ¹ / ₂	7 ⁸ / ₁₆	(17) #14 ⁷	2-33 (2-20)	7,335	0.12	11,715	0.204	13,720	IBC, FL, LA
							2-43 (2-18)	8,750	0.086	13,975	0.146	21,435	
							2-54 (2-16)	8,855	0.106	14,145	0.162	21,700	
							Steel fixture	10,840	0.053	17,335	0.072	32,525	
S/HD10S	118 (10)	13 ¹ / ₂	2 ⁵ / ₁₆	1 ¹ / ₂	7 ⁸ / ₁₆	(22) #14 ⁷	2-33 (2-20)	7,400	0.122	11,815	0.192	13,835	
							2-43 (2-18)	11,120	0.112	17,755	0.124	20,795	
							2-54 (2-16)	12,220	0.096	19,520	0.145	29,940	
							Steel fixture	12,375	0.043	19,820	0.061	33,535	
S/HD15S	171 (7)	17	2 ⁵ / ₁₆	1 ⁹ / ₁₆	1	(30) #14 ⁷	2-43 (2-18)	12,110	0.096	19,340	0.164	22,645	
							2-54 (2-16)	13,500	0.11	21,565	0.13	33,075	
							Steel fixture	15,810	0.043	25,320	0.065	42,845	
S/HD8B	171 (7)	11	2 ⁵ / ₁₆	1 ¹ / ₂	7 ⁸ / ₁₆	(2) 3/4" dia.	2-33 (2-20)	3,895	0.081	5,620	0.144	8,645	
							2-43 (2-18)	5,345	0.098	7,710	0.146	11,865	
							2-54 (2-16)	8,950	0.082	14,280	0.141	20,310	
							Steel fixture	9,080	0.069	14,545	0.104	22,975	
S/HD10B	118 (10)	13 ¹ / ₂	2 ⁵ / ₁₆	1 ¹ / ₂	7 ⁸ / ₁₆	(3) 3/4" dia.	2-33 (2-20)	5,840	0.070	8,430	0.124	12,970	
							2-43 (2-18)	8,015	0.087	11,565	0.12	17,795	
							2-54 (2-16)	12,090	0.125	19,720	0.23	28,050	
							Steel fixture	15,635	0.102	24,955	0.123	35,495	
S/HD15B	171 (7)	17	2 ⁵ / ₁₆	1 ⁹ / ₁₆	1	(4) 3/4" dia.	2-43 (2-18)	16,020	0.118	15,425	0.179	22,165	
							2-54 (2-16)	16,020	0.090	25,565	0.121	36,360	
							Steel fixture	18,690	0.104	29,825	0.139	42,425	

These products are available with additional corrosion protection. Additional products on this page may also be available with this option. Check with Simpson Strong-Tie for details.

- The designer shall specify the foundation anchor material type, embedment and configuration. Some of the tabulated holddown tension loads exceed the tension strength of typical ASTM A36 or A307 anchor bolts.
- Stud design by specifier. Tabulated loads are based on a minimum stud thickness for fastener connection.
- 1/4" self-drilling screws may be substituted for #14 self-tapping screws.
- Deflection at ASD or LRFD includes fastener slip, holddown deformation and anchor rod elongation for holdowns installed up to 4" above top of concrete. Holdowns may be installed raised, up to 18" above top of concrete, with no load reduction provided that additional elongation of the anchor rod is accounted for. See bottom of p. 169 for installation detail.
- The Nominal Tension Load is based on the tested average ultimate (peak) load and is provided for design in accordance with section C5 of AISI S213 that requires a holddown to have a nominal strength to resist the lesser of the amplified seismic load or the maximum force the system can deliver.
- Not all fastener holes for S/HDS holdowns need to be filled, as additional fastener holes provided. Install fasteners symmetrically.
- See *Fastening Systems* catalog (C-F-2019) on strongtie.com for more information on Simpson Strong-Tie fasteners.