

# L/LS/GA

## Reinforcing and Skewable Angles

L — Staggered nail pattern reduces the possibility for splitting.  
LS — Field-adjustable 0° to 135° angles.

GA — Gusset angles' embossed bend section provides added strength.

**Material:** L — 16 gauge; GA and LS — 18 gauge

**Finish:** Galvanized. Some products available in stainless steel or ZMAX® coating; L70 and L90 available (in Spring 2026) in black powder coat (L70PC, L90PC)

**Installation:**

- Use all specified fasteners; see General Notes
- LS — Field skewable; bend one time only
- Joist must be constrained against rotation (for example, with solid blocking) when using a single LS per connection
- Nail the L angle's wider leg into the joist to ensure table loads and allow correct nailing

**Codes:** See p. 12 for Code Reference Key Chart

**Web Applications:** Visit [app.strongtie.com/rws](http://app.strongtie.com/rws) to access our Roof-to-Wall Selector web application.

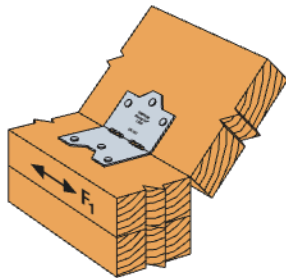
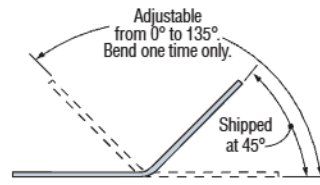
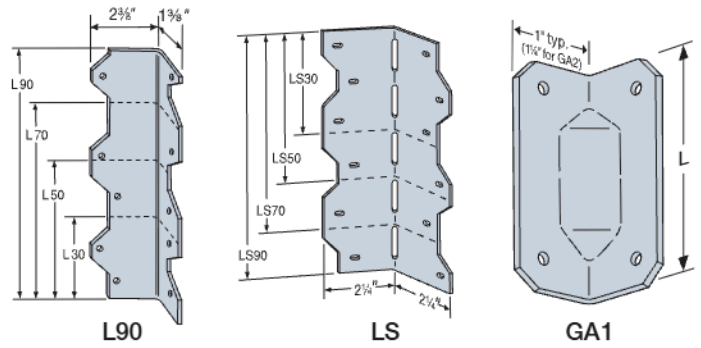

Typical LS30 Installation

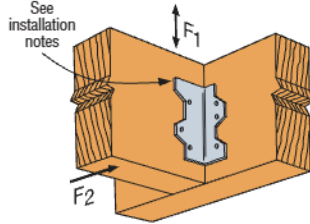

Typical L50 Installation

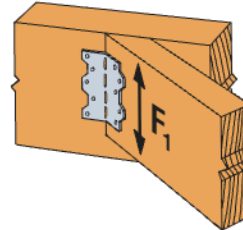

Typical LS70 Installation

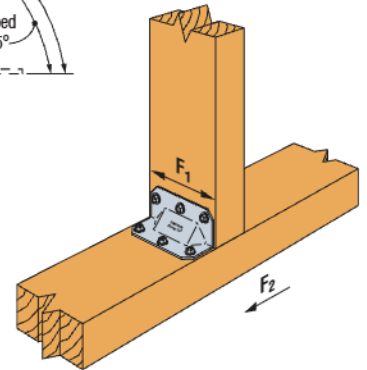

Typical GA Installation

These products are available with additional corrosion protection. For more information, see pp. 13–19.

**SS** For stainless-steel fasteners, see p. 25.

**SD** Many of these products are approved for installation with Strong-Drive® SD Connector screws. See pp. 380–382 for more information.

Model No.	Fasteners (in.)	L (in.)	Load Direction	DF/SP Allowable Loads				SPF/HF Allowable Loads				Code Ref.
				Floor (100)	Snow (115)	Roof (125)	Wind/Seismic (160)	Floor (100)	Snow (115)	Roof (125)	Wind/Seismic (160)	
GA1	(4) 0.148 x 1 1/2	2 3/4	F <sub>1</sub> , F <sub>2</sub>	235	270	290	350	200	230	250	300	IBC, FL, LA
	(4) #9 x 1 1/2" SD		F <sub>1</sub>	340	375	375	375	225	260	280	325	
	(4) #9 x 1 1/2" SD		F <sub>2</sub>	340	395	430	435	225	260	280	360	
GA2	(6) 0.148 x 1 1/2	3 1/4	F <sub>1</sub> , F <sub>2</sub>	355	405	435	550	305	350	375	475	IBC, FL, LA
	(6) #9 x 1 1/2" SD		F <sub>1</sub>	515	590	640	695	335	385	420	540	
	(6) #9 x 1 1/2" SD		F <sub>2</sub>	515	590	640	820	335	385	420	540	
L30	(4) 0.148 x 1 1/2	3	F <sub>1</sub>	245	250	250	250	210	215	215	215	IBC, FL, LA
			F <sub>2</sub>	245	275	295	370	210	235	255	320	
L50	(6) 0.148 x 1 1/2	5	F <sub>1</sub>	365	415	445	525	315	355	385	450	
			F <sub>2</sub>	365	415	445	555	315	355	385	475	
L70	(8) 0.148 x 1 1/2	7	F <sub>1</sub> , F <sub>2</sub>	485	550	595	740	415	475	510	635	
			F <sub>1</sub> , F <sub>2</sub>	610	690	740	925	525	595	635	795	
L90	(10) 0.148 x 1 1/2	9	F <sub>1</sub> , F <sub>2</sub>	610	690	740	925	525	595	635	795	
			F <sub>1</sub>	320	320	320	320	275	275	275	275	
LS30	(6) 0.148 x 1 1/2	3 3/8	F <sub>1</sub>	355	395	395	395	305	340	340	340	
	(6) 0.148 x 3		F <sub>1</sub>	355	395	395	395	305	340	340	340	
<b>SS</b> LS50	(8) 0.148 x 1 1/2	4 7/8	F <sub>1</sub>	475	540	560	560	410	465	480	480	
	(8) 0.148 x 3		F <sub>1</sub>	475	540	580	730	410	465	500	630	
LS70	(10) 0.148 x 1 1/2	6 3/8	F <sub>1</sub>	590	645	645	645	510	555	555	555	
	(10) 0.148 x 3		F <sub>1</sub>	590	675	725	915	510	580	625	785	
LS90	(12) 0.148 x 1 1/2	7 7/8	F <sub>1</sub>	710	805	870	890	610	690	750	765	
	(12) 0.148 x 3		F <sub>1</sub>	710	805	870	1,040	610	690	750	895	

- GA angles may be installed with 0.148" x 3" nails.
- GA1 uplift is 425 lb. for DF and 300 lb. for SPF when installed with Strong-Drive SD Connector screws.
- GA2 uplift is 370 lb. for DF and 260 lb. for SPF when installed with Strong-Drive SD Connector screws.
- Connectors are required on both sides to achieve F<sub>2</sub> loads in both directions.
- Fasteners:** Nail dimensions are listed diameter by length. SD screws are Simpson Strong-Tie Strong-Drive SD Connector screws. See pp. 25–26 for fastener information.
- Using Strong-Drive SD Connector screw (SD9112) for 0.148" x 1 1/2" and 0.148" x 3" nails will get the same load as nails.