

## Exterior Screws

# Strong-Drive® SDWH TIMBER-HEX Screw

### Structural Wood and Engineered Wood Connections Including Ledgers

Ideal for structural and general-purpose fastening applications where a hex-head drive is preferred. Strong-Drive SDWH Timber-Hex screws are ideal for the contractor and do-it-yourselfer alike. It is code listed under IAPMO-UES ER-192 and meets 2015 and 2018 IRC® and IBC® code requirements for several common wood framing applications.

#### Features:

- Bold thread design provides superior holding power
- SawTooth™ point ensures fast starts, reduces installation torque and eliminates the need for predrilling in most applications
- Underhead nibs offer greater control when seating the head
- Large washer head provides maximum bearing area (0.64" washer head dia.)
- Size identification on all SDWH screw heads
- 5/16" hex drive (replacement driver bit — BITHEXR516-134)

*Double-barrier coating provides corrosion resistance equivalent to hot-dip galvanization, making it suitable for certain exterior and preservative-treated wood applications, as described in the evaluation report.*

**Codes/Standards:** IAPMO-UES ER-192, State of Florida FL13975

**For Technical Data and Loads,** see Technical Supplement  
US Patent 9,523,383

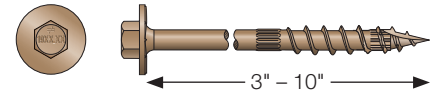

### Double-Barrier Coating

Size Dia. x L (in.)	Thread Length (in.)	Flagged Fasteners		Retail Clam		Retail Pack		Mini-bulk		Bulk	
		Fast. per Pack	Model No.	Fast. per Pack	Model No.	Fast. per Pack	Model No.	Fast. per Pack	Model No.	Fast. per Pack	Model No.
0.195 x 3	1 1/2	1	SDWH19300DB-RP1	12	SDWH19300DB-RC12	50	SDWH19300DB-R50	250	SDWH19300DBMB	1,000	SDWH19300DB
0.195 x 4	2 3/8	1	SDWH19400DB-RP1	12	SDWH19400DB-RC12	50	SDWH19400DB-R50	250	SDWH19400DBMB	800	SDWH19400DB
0.195 x 6	2 3/4	1	SDWH19600DB-RP1	12	SDWH19600DB-RC12	50	SDWH19600DB-R50	250	SDWH19600DBMB	600	SDWH19600DB
0.195 x 8	2 3/4	1	SDWH19800DB-RP1	12	SDWH19800DB-RC12	50	SDWH19800DB-R50	250	SDWH19800DBMB	500	SDWH19800DB
0.195 x 10	2 3/4	1	SDWH191000DB-RP1	12	SDWH191000DBRC12	50	SDWH191000DB-R50	250	—	250	SDWH191000DB

Retail and mini-bulk packs include one 5/16" hex driver bit; bulk packs include two driver bits.

Flagged fasteners per master carton: 40; retail clam packs per master carton: 10; retail pack packs per master carton: 6.

# Structural and General Fastening

## Strong-Drive® SDWH TIMBER-HEX Screw

Structural Wood-to-Wood Connections Including Ledgers, Indoor/Outdoor Projects

Double-barrier coating provides corrosion resistance equivalent to hot-dip galvanization, making it suitable for certain exterior and preservative-treated wood applications, as described in the evaluation report.

**Codes/Standards:** IAPMO-UES ER-192, State of Florida FL13975

US Patent 9,523,383

For more information, see p. 55, C-F-2019 Fastening Systems Catalog

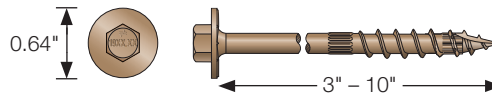

### SDWH — Allowable Shear Loads — Douglas Fir–Larch and Southern Pine Lumber

Size (dia. x length) (in.)	Model No.	Thread Length (in.)	Reference DFL/SP Allowable Shear Loads (lb.)									
			Wood Side Member Thickness (in.)									
			1.5	2	2.5	3	3.5	4	4.5	6	8	
0.195 x 3	SDWH19300DB	1½	285	—	—	—	—	—	—	—	—	—
0.195 x 4	SDWH19400DB	2¾	370	300	300	—	—	—	—	—	—	—
0.195 x 6	SDWH19600DB	2¾	370	265	265	265	265	245	245	—	—	—
0.195 x 8	SDWH19800DB	2¾	370	265	265	265	265	265	260	245	—	—
0.195 x 10	SDWH191000DB	2¾	370	265	265	265	265	265	260	260	245	—

See footnotes below.

### SDWH — Allowable Shear Loads — Spruce-Pine-Fir and Hem-Fir Lumber

Size (dia. x length) (in.)	Model No.	Thread Length (in.)	Reference SPF/HF Allowable Shear Loads (lb.)									
			Wood Side Member Thickness (in.)									
			1.5	2	2.5	3	3.5	4	4.5	6	8	
0.195 x 3	SDWH19300DB	1½	230	—	—	—	—	—	—	—	—	—
0.195 x 4	SDWH19400DB	2¾	330	235	195	—	—	—	—	—	—	—
0.195 x 6	SDWH19600DB	2¾	350	265	265	265	265	215	180	—	—	—
0.195 x 8	SDWH19800DB	2¾	350	265	265	265	265	265	215	215	—	—
0.195 x 10	SDWH191000DB	2¾	350	265	265	265	265	265	250	250	215	—

- All applications are based on full penetration into the main member. Full penetration is the screw length minus the side member thickness.
- Allowable loads are shown at the wood load duration factor of  $C_D = 1.0$ . Loads may be increased for load duration per the building code up to a  $C_D = 1.6$ . Tabulated values must be multiplied by all applicable adjustment factors per the NDS.
- Minimum fastener spacing requirements to achieve table loads: 6" end distance, 1¼" edge distance, ¾" between staggered rows of fasteners, 4" between non-staggered rows of fasteners and 8" between fasteners in a row.
- For in-service moisture content greater than 19%, use  $C_M = 0.7$ .
- Loads are based on installation into the side grain of the wood with the screw axis perpendicular to the face of the member.

# Structural and General Fastening

## Strong-Drive® SDWH TIMBER-HEX Screw (cont.)

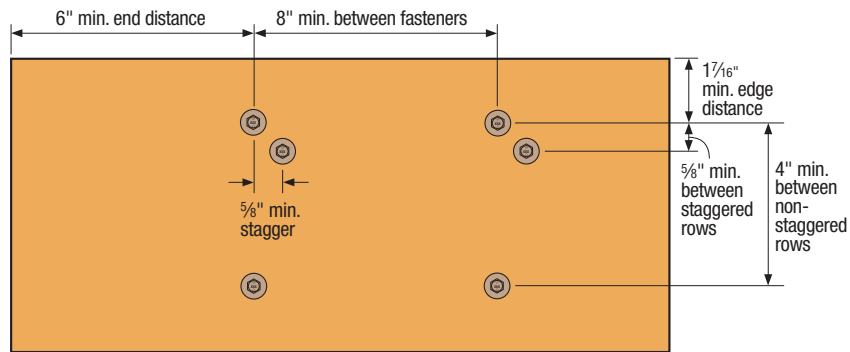

**SDWH Spacing Requirements**

### SDWH — Allowable Withdrawal Loads — Douglas Fir-Larch, Southern Pine, Spruce-Pine-Fir and Hem-Fir Lumber

Size (dia. x length) (in.)	Model No.	Fastener Length (in.)	Thread Length (in.)	Reference Withdrawal Design Value, W (lb./in.)		Max. Reference Withdrawal Design Value, W <sub>max</sub> (lb.)	
				DFL and SP Main Member	HF and SPF Main Member	DFL and SP Main Member	HF and SPF Main Member
0.195 x 3	SDWH19300DB	3	1½	177	120	265	180
0.195 x 4	SDWH19400DB	4	2¾	192	147	455	350
0.195 x 6	SDWH19600DB	6	2¾	197	164	545	445
0.195 x 8	SDWH19800DB	8	2¾	197	164	545	445
0.195 x 10	SDWH191000DB	10	2¾	197	164	545	445

1. The tabulated reference withdrawal design value, W, is in pounds per inch of the thread penetration into the side grain of the main member.
2. The tabulated reference withdrawal design value, W<sub>max</sub>, is in pounds where the entire thread length must penetrate into the side grain of the main member.
3. Tabulated reference withdrawal design values, W and W<sub>max</sub>, are shown at a C<sub>D</sub> = 1.0. Loads may be increased for load duration per the building code up to a C<sub>D</sub> = 1.6. Tabulated values must be multiplied by all applicable adjustment factors from the NDS as referenced in the IBC or IRC.
4. Embedded thread length is that portion held in the main member including the screw point.
5. Values are based on the lesser of withdrawal from the main member or pull-through of a 1½" side member.
6. For in-service moisture content greater than 19%, use C<sub>M</sub> = 0.7.

## Structural and General Fastening

### Strong-Drive® SDWH TIMBER-HEX Screw with Gypsum Board Interlayer(s)

The Strong-Drive SDWH Timber-Hex screw may be installed with one or two layers of 5/8" gypsum board. This layer of gypsum is to be located between the side member and the main member for a standard connection. See table for the required screw lengths and allowable loads for these applications. Loads are derived from assembly testing based on ICC-ES AC233.

#### SDWH Timber-Hex Screw — Douglas Fir-Larch and Southern Pine Lumber Allowable Single Shear Loads with One Layer of 5/8" Gypsum Board

Size (in.)	Model No.	Thread Length (in.)	Reference DFL/SP Allowable Shear Loads (lb.)								
			Wood Side Member Thickness (in.)								
			1.5	2.0	2.5	3.0	3.5	4.0	4.5	6.0	8.0
0.19 x 4	SDWH19400DB	2.375	240	—	—	—	—	—	—	—	—
0.19 x 6	SDWH19600DB	2.75	240	170	170	170	170	—	—	—	—
0.19 x 8	SDWH19800DB	2.75	240	170	170	170	170	170	170	—	—
0.19 x 10	SDWH191000DB	2.75	240	170	170	170	170	170	170	170	—

See notes on following page.

#### SDWH Timber-Hex Screw — Douglas Fir-Larch and Southern Pine Lumber Allowable Single Shear Loads with Two Layers of 5/8" Gypsum Board

Size (in.)	Model No.	Thread Length (in.)	Reference DFL/SP Allowable Shear Loads (lb.)								
			Wood Side Member Thickness (in.)								
			1.5	2.0	2.5	3.0	3.5	4.0	4.5	6.0	8.0
0.19 x 4	SDWH19400DB	2.375	—	—	—	—	—	—	—	—	—
0.19 x 6	SDWH19600DB	2.75	240	170	170	170	—	—	—	—	—
0.19 x 8	SDWH19800DB	2.75	240	170	170	170	170	170	170	—	—
0.19 x 10	SDWH191000DB	2.75	240	170	170	170	170	170	170	170	—

See notes on following page.

#### SDWH Timber-Hex Screw — Spruce-Pine-Fir and Hem-Fir Lumber Allowable Single Shear Loads with One Layer of 5/8" Gypsum Board

Size (in.)	Model No.	Thread Length (in.)	Reference SPF/HF Allowable Shear Loads (lb.)								
			Wood Side Member Thickness (in.)								
			1.5	2.0	2.5	3.0	3.5	4.0	4.5	6.0	8.0
0.19 x 4	SDWH19400DB	2.375	215	—	—	—	—	—	—	—	—
0.19 x 6	SDWH19600DB	2.75	230	170	170	170	170	—	—	—	—
0.19 x 8	SDWH19800DB	2.75	230	170	170	170	170	170	140	—	—
0.19 x 10	SDWH191000DB	2.75	230	170	170	170	170	170	165	165	—

See notes on following page.

# Structural and General Fastening

## **Strong-Drive®** SDWH **TIMBER-HEX** Screw with Gypsum Board Interlayer(s) (cont.)

SDWH Timber-Hex Screw — Spruce-Pine-Fir and Hem-Fir Lumber  
Allowable Single Shear Loads with Two Layers of 5/8" Gypsum Board

Size (in.)	Model No.	Thread Length	Reference SPF/HF Allowable Shear Loads (lb.)									
			Wood Side Member Thickness (in.)									
			1.5	2.0	2.5	3.0	3.5	4.0	4.5	6.0	8.0	
0.19 x 4	SDWH19400DB	2.375	215	—	—	—	—	—	—	—	—	—
0.19 x 6	SDWH19600DB	2.75	230	170	170	170	—	—	—	—	—	—
0.19 x 8	SDWH19800DB	2.75	230	170	170	170	170	170	140	—	—	—
0.19 x 10	SDWH191000DB	2.75	230	170	170	170	170	170	170	165	165	—

1. All applications are based on full penetration which equals fastener length minus member thickness.
2. Allowable loads are shown at the wood load duration factor of  $C_D = 1.0$ . Loads may be increase for load duration per the building code up to a  $C_D = 1.6$ . Tabulated values must be multiplied by all applicable adjustment factors per the NDS.
3. Minimum fastener spacing requirements: 6" end distance, 1 7/16" edge distance, 5/8" between staggered rows of fasteners, 4" between non-staggered rows of fasteners and 8" between fasteners in a row. See figure below.
4. For in-service moisture content greater than 19% use  $C_M = 0.7$ .
5. Gypsum board must be attached as required per the building code.

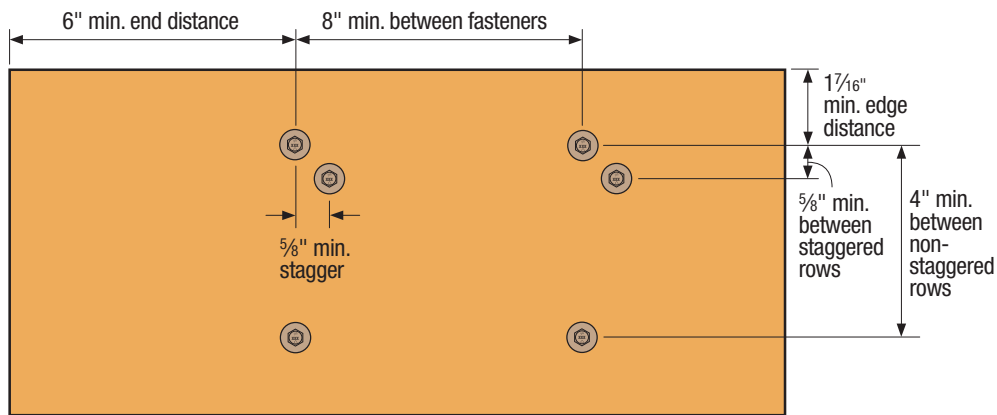

**Spacing Requirements**

# Ledger Structural Fastening Applications

## Strong-Drive® SDWH TIMBER-HEX Screw in Ledger-to-Stud Applications

Strong-Drive SDWH Timber-Hex screws may be used to attach a ledger to the narrow face of nominal 2x lumber studs according to the following table. Tests and analyses were performed in accordance with ICC-ES Acceptance Criteria AC233.

For more information, see p. 55, C-F-2019 Fastening Systems Catalog

### SDWH Timber-Hex Screw — Allowable Shear Loads for Ledger to Studs

Size (in.)	Model No.	Nominal Ledger Size (in.)	Number of Screws per Stud	Reference Allowable Shear Load (lb.)		
				SP	DFL	SPF/HF
0.197 x 4	SDWH19400DB	2x6	2	630	630	540
		2x8	3	630	815	815
		2x10	4	—	1,170	975

- Allowable loads shall be limited to parallel-to-grain loaded solid sawn main members (minimum 2" nominal). Wood side members shall be loaded perpendicular to grain.
- Allowable loads are based on DFL, SPF/HF, and SP wood members having a minimum specific gravity of 0.50, 0.42, and 0.55, respectively. Where the side and main members have different specific gravities, the lower values shall be used.
- Allowable loads are shown at the wood load duration factor of  $C_D = 1.00$ . Loads may be increased for load duration as permitted by the building code up to a  $C_D = 1.60$ .  
For in-service moisture content greater than 19%, use  $C_M = 0.70$ .
- Fasteners shall be centered in the stud and spaced as shown in the figure. The stud minimum end distance is 6" when loaded toward the end and 2½" when loaded away from the end. The ledger end distance is 6" for full values. For ledger end distanced between 2" and 6" use 50% of the table loads. For end distances between 2" and 4", predrill using a ⅛" bit for the SDWH.
- Screws may be installed with an intermediate layer of wood structural panel between the side and main member provided the wood structural panel is fastened to the main member per code and the minimum screw penetration of 2½" into the main member (excluding the wood structural panel) is met. Longer lengths of the screw series may be used.
- For LRFD values, the reference connection design values shall be adjusted in accordance with the NDS-2018, section 11.3.
- For 2x10 SP ledgers, use the number of screws and allowable loads of the 2x8 SP ledger.
- For 2x8 ledgers with two screws, use 2x6 values. For 2x10 ledgers with three screws, use 2x8 values. Spacings and edge distances shown in the figure are minimum dimensions.
- For loads in the opposite direction from that shown in the figure, use the table values multiplied by: 0.50 for two-screw connections, 0.67 for three-screw connections, and 0.75 for four-screw connections.

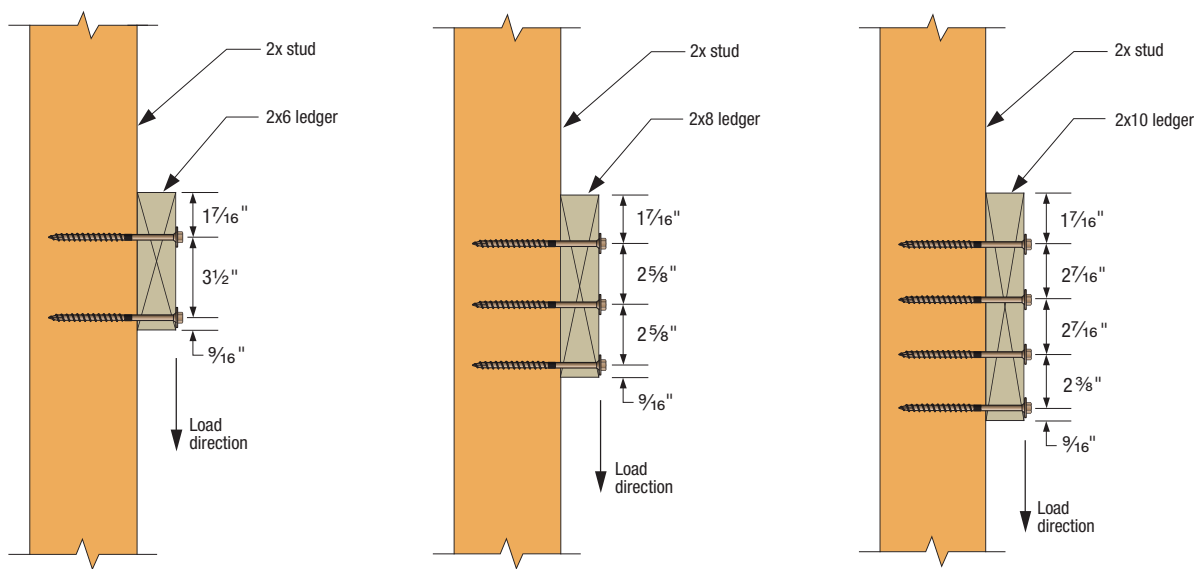

## Ledger Structural Fastening Applications

## Strong-Drive® SDWH TIMBER-HEX Screw with Gypsum Board Interlayer(s)

SDWH Timber-Hex Screw — Allowable Shear Loads for Ledger Attachment to Studs with One or Two Layers of 5/8" Gypsum Board

Size (in.)	Model No.	Nominal Ledger Size (in.)	Number of Screws per Stud	Reference Allowable Shear Load (lb.)		
				SP	DFL	SPF/HF
0.19 x 6	SDWH19600DB	2x6	2	410	410	350
		2x8	3	410	530	530
		2x10	4	—	760	635

- Allowable loads shall be limited to parallel-to-grain loaded solid sawn main members (minimum 2" nominal). Wood side members shall be loaded perpendicular to grain.
- Allowable loads are based on DFL, SPF/HF, and SP wood members having a minimum specific gravity of 0.50, 0.42, and 0.55, respectively. Where the side and main members have different specific gravities, the lower values shall be used.
- Allowable loads are shown at the wood load duration factor of  $C_D = 1.00$ . Loads may be increased for load duration as permitted by the building code up to a  $C_D = 1.60$ . All adjustment factors shall be applied per the National Design Specification (NDS). For in-service moisture content greater than 19%, use  $C_M = 0.70$ .
- Fasteners shall be centered in the stud and spaced as shown in the figure. The ledger minimum end distance is 6". The stud minimum end distance is 6" when the load is toward the end and 2 1/2" when the load is away from the end. For ledger end distances between 2" and 6", use half of table loads and predrill with 1/8" drill bit.
- Screws may be installed with an interlayer of wood structural panel (WSP) between the framing and the gypsum panel(s). When a WSP is present, it shall be a maximum of 1/2" thick, adjacent to the framing and fastened directly to the framing per code. Minimum screw penetration into the framing of 2 1/2" shall be required; longer screw lengths shall be used to achieve the required penetration.
- For LRFD values, the reference connection design values shall be adjusted in accordance with the NDS-2018, section 11.3.
- For 2x10 SP ledgers, use the number of screws and allowable loads of the 2x8 SP ledger.
- For 2x8 ledgers with two screws, use 2x6 values. For 2x10 ledgers with three screws, use 2x8 values. Spacings and edge distances shown in the figure are minimum dimensions.
- For loads in the opposite direction from that shown in the figure, use the table values multiplied by: 0.50 for two-screw connections, 0.67 for three-screw connections, and 0.75 for four-screw connections.
- Gypsum board must be attached as required per the building code.

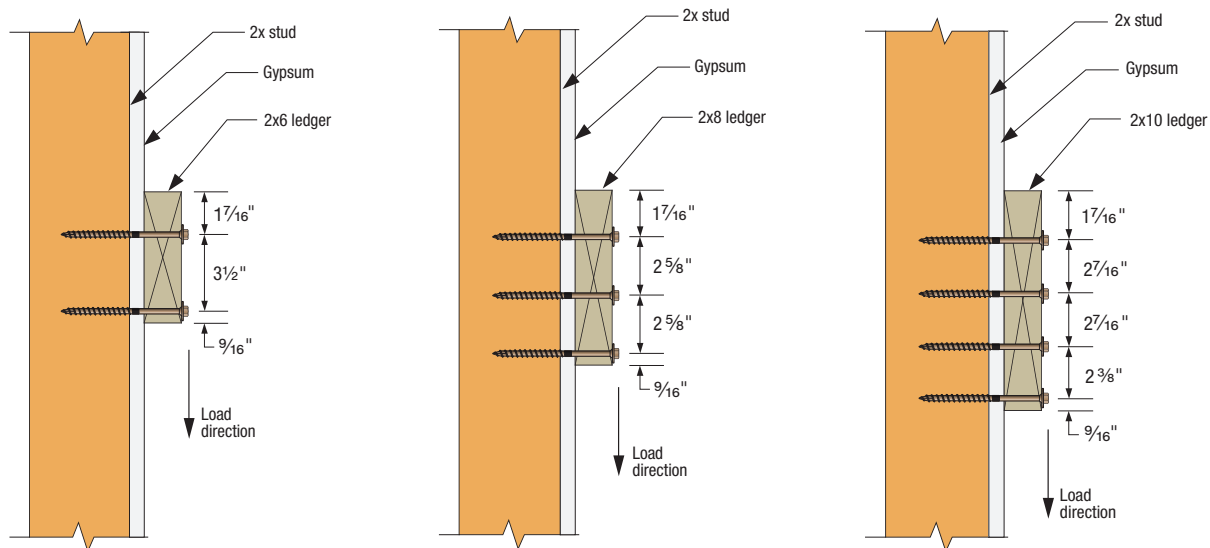

**Note:** Minimum stud dimension is nominal 2 x 6.

### Notes to Installer Regarding the Attachment of Ledgers to Studs:

The screws must be installed into the middle of the stud with a tolerance of 3/16" either side of center. Various methods can be used to ensure proper placement of the screws in the stud including snapping a chalk line, using a stud finder, or prerocking (attaching only a strip of gypsum at the ledger location until the ledger is fastened to the studs). If proper screw placement into the stud cannot be achieved in the field, blocking should be installed between studs to receive and support the ledger screws.

# Ledger Structural Fastening Applications

## Strong-Drive® SDWH TIMBER-HEX Screw with Gypsum Board Interlayer(s) (cont.)

SDWH Timber-Hex Screw — 2015 and 2018 IRC Compliant Spacing for a Sawn Lumber Ledger to Rim Board with One or Two Layers of 5/8" Gypsum Board

Loading Condition	Nominal Ledger Thickness (in.)	Model No.	Rim Board Material and Minimum Size	Maximum Deck Joist Span						
				Up to 6 ft.	Up to 8 ft.	Up to 10 ft.	Up to 12 ft.	Up to 14 ft.	Up to 16 ft.	Up to 18 ft.
				Maximum On-Center Spacing of Fasteners (in.)						
40 psf Live 10 psf Dead	2x	For one layer of gypsum board use: SDWH19400DB For two layers of gypsum board use: SDWH19600DB	1" OSB 1" LVL	12	9	7	6	5	4	4
			1 1/8" OSB 1 1/4" LVL 1 1/4" LSL	17	12	10	8	7	6	6
			2x SP, DFL 2x SPF, HF	14	11	9	7	6	5	5
60 psf Live 10 psf Dead	2x	For one layer of gypsum board use: SDWH19400DB For two layers of gypsum board use: SDWH19600DB	1" OSB 1" LVL	8	6	5	4	4	—	—
			1 1/8" OSB 1 1/4" LVL 1 1/4" LSL	12	9	7	6	5	4	4
			2x SP, DFL 2x SPF, HF	10	8	6	5	4	4	—
100 psf Live 10 psf Dead	2x	For one layer of gypsum board use: SDWH19400DB For two layers of gypsum board use: SDWH19600DB	1" OSB 1" LVL	5	4	—	—	—	—	—
			1 1/8" OSB 1 1/4" LV 1 1/4" LSL	8	6	5	4	—	—	—
			2x SP, DFL 2x SPF, HF	7	5	4	—	—	—	—

- Solid-sawn rim board shall be spruce-pine-fir, hem-fir, Douglas fir-larch, or southern pine species. Ledger shall be hem-fir, Douglas fir-larch, or southern pine species.
- Fastener spacings are based on the lesser of single fastener ICC-ES AC233 testing of the Strong-Drive® SDWH screw with a safety factor of 5.0 or ledger assembly testing based on ICC-ES AC13 with a factor of safety of 3.0. Spacing does NOT include NDS wet service factor adjustment.
- Multiple ledger plies shall be fastened together per code independent of the SDWH screws.
- SDWH screw spacing values are equivalent to 2018 IRC Table R507.9.1.3(1) and 2015 IRC Table R507.2. The tables also provide SDWH screw spacing for a wider range of materials commonly used for rim board, and an alternate loading condition as required by some jurisdictions.
- Rows of screws shall be vertically offset and evenly staggered. Screws shall be placed 1 1/2" to 2" from the top and bottom of the ledger or rim board with 3" minimum and 6" maximum between rows and spaced per the table. End screws shall be located 6" from the end and at 1 1/2" to 2" from the bottom of the ledger. For screws located at least 2" but less than 6" from the end, use 50% of the load per screw and 50% of the table spacing between the end screw and the adjacent screw, and for screws located between 2" and 4" from the end, predrill using a 1/8" drill.
- The design installation permits a wood structural panel (WSP) interlayer in addition to one or two layers of gypsum board. If present, the WSP shall be a maximum of 1/2" thick, adjacent to the framing and fastened directly to the framing per the code.
- Gypsum board must be attached as required per the building code.

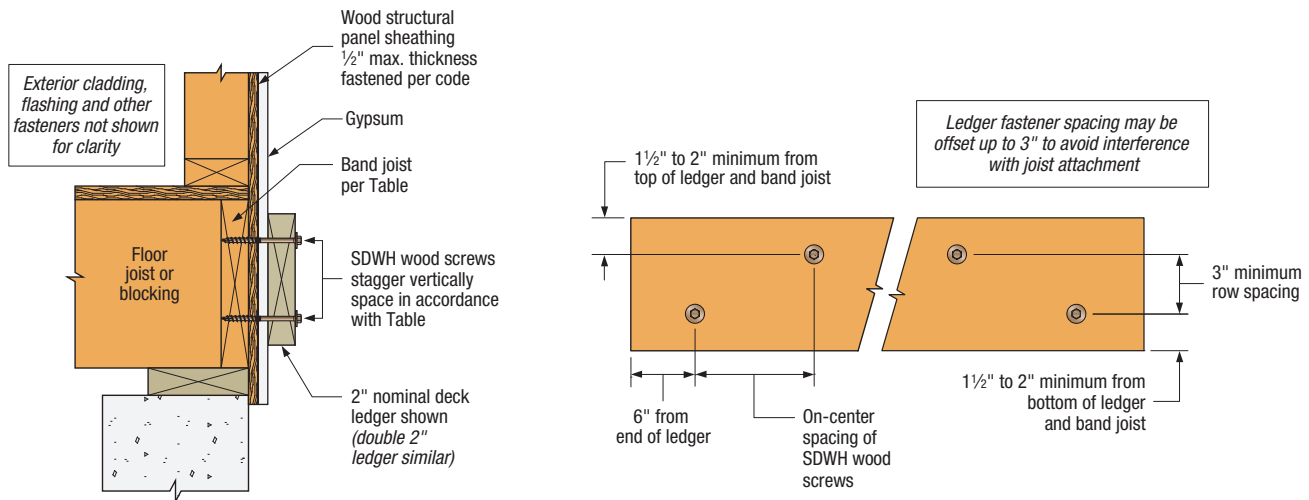

**Ledger-to-Rim Board Assembly**  
(wood-framed lower floor acceptable, concrete wall shown for illustration purposes)

**SDWH Screw Spacing Detail**



# Sole/Top Plate-to-Rim Fastening

## Strong-Drive® SDWH TIMBER-HEX Screw

### Sole-to-Rim Connections

For more information, see p. 55, C-F-2019 Fastening Systems Catalog

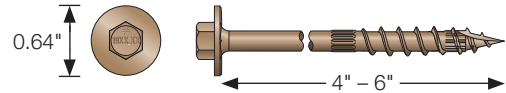

### SDWH — Allowable Shear Loads for Sole-to-Rim Connections

Size (in.)	Model No.	Nominal Sole Plate Thickness (in.)	Minimum Penetration into Rim Board (in.)	Reference Allowable Loads (lb.) per Screw							
				2x DFL/SP Rim Board		2x SPF/HF Rim Board		1 1/4" Min. LVL Rim Board		1 1/4" Min. LSL Rim Board	
				DFL/SP Sole Plate	SPF/HF Sole Plate	DFL/SP Sole Plate	SPF/HF Sole Plate	DFL/SP Sole Plate	SPF/HF Sole Plate	DFL/SP Sole Plate	SPF/HF Sole Plate
0.195 x 4	SDWH19400DB	2x	1.75	315	295	295	295	255	255	275	275
0.195 x 6	SDWH19600DB	2x, 3x, (2)-2x	2	315	295	295	295	255	255	275	275

1. Allowable loads are based on testing per ICC-ES AC233 and are limited to parallel-to-grain loading.
2. Allowable loads are shown at the wood load duration factor of  $C_D = 1.00$ . Loads may be increased for load duration by the building code up to a  $C_D = 1.60$ .
3. Minimum spacing of the SDWH is 6" o.c., minimum end distance is 6", and minimum edge distance is 5/8".
4. Wood structural panel up to 1 1/8" thick is permitted between the sole plate and rim board provided it is fastened to the rim board per code and the minimum penetration of the screw into the rim board is met.
5. A double 2x sole/top plate is permitted provided it is independently fastened per the code and the minimum screw penetration per the table is met.
6. Minimum rim board height shall be 9 1/4" when using SDWH fasteners for sole and top plate fastening.
7. Sole-to-rim loads can be achieved with a wall below.

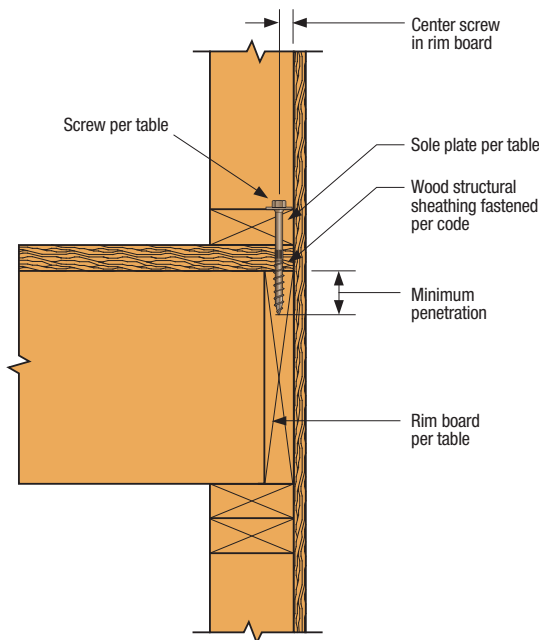

**Sole-to-Rim Board Assembly**  
(Other fasteners not shown for clarity)

# Sole / Top Plate-to-Rim Fastening

## **Strong-Drive®** SDWS TIMBER Screw and SDWH TIMBER-HEX Screw

### Sole Plate/Top Plate to Rim/Blocking Shear Load Transfer with Reduced Fastener Spacing

Strong-Drive SDWS Timber and Strong-Drive SDWH Timber-Hex structural screws may be used to attach a sole plate or top plate to a rim board and blocking material according to the following details and loading information. Allowable loads are based on testing per ICC-ES AC233 and are limited to parallel-to-grain or in-plane-shear loading. Each test assembly consisted of multiple fasteners, a sole plate, sheathing and a rim board or blocking material. Please see the following for allowable load tables.

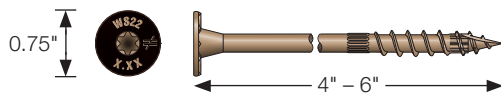

**Strong-Drive SDWS TIMBER Screw**

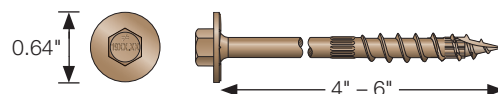

**Strong-Drive SDWH TIMBER-HEX Screw**

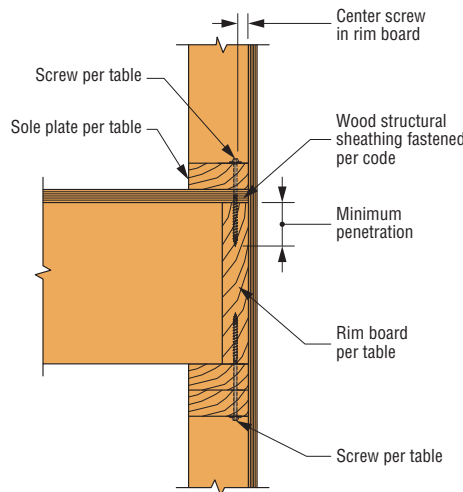

**Sole-to-Rim and Top Plate-to-Rim Connection**

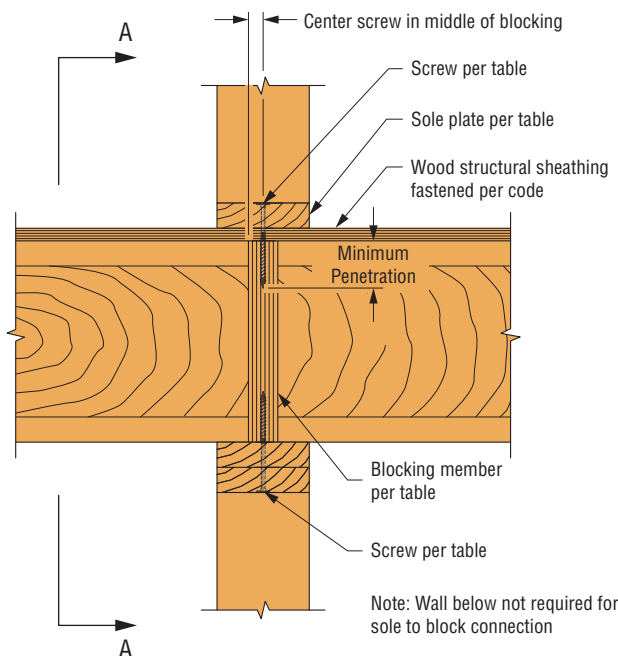

**Sole-to-Block and Top Plate-to-Block Connection**

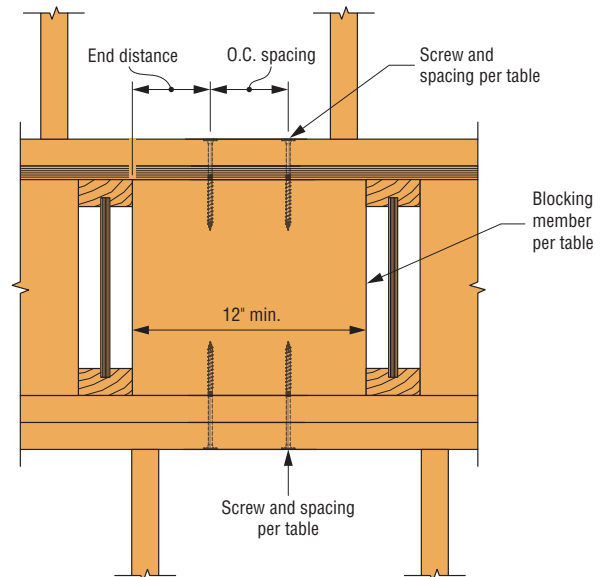

**Sole-to-Block and Top Plate-to-Block Connection**

## Sole/Top Plate-to-Rim Fastening

### Strong-Drive® SDWS TIMBER Screw and SDWH TIMBER-HEX Screw (cont.)

SDWS Timber/SDWH Timber-Hex Single-Fastener, Allowable Loads for Sole-to-Rim (or Blocking) and Top Plate-to-Rim (or Blocking) Connection

Min. Screw Length (in.)	Sole Plate or Top Plate Nominal Thickness	Model No.	Min. Penetration into Rim or Block (in.)	Reference Allowable Shear Loads (lb.) per Screw DFL/SP Sole Plate and Top Plate					
				Rim and Blocking Material					
				2x Min. DFL/SP		1 ¼" Min. LVL	1 ¼" Min. LVL	1 ¼" Min. LSL	1 ¼" Min. LSL
				6" O.C. 6" End Distance	3" O.C. 3" End Distance	6" O.C. 6" End Distance	4" O.C. 4" End Distance	6" O.C. 6" End Distance	4" O.C. 4" End Distance
4	Sole Plate	2x SDWH19400DB	1.75	315	220	255	260	275	230
4		2x SDWS22400DB	1.75	345	240	275	305	275	350
5		2x SDWS22500DB	2	345	240	275	360	275	345
6		3x SDWH19600DB	2	315	225	255	260	275	230
6		3x SDWS22600DB	2	345	240	275	360	275	345
6		(2) 2x SDWH19600DB	1.75	315	220	255	260	275	230
6		(2) 2x SDWS22600DB	1.75	345	240	275	305	275	350
8		(2) 2x SDWH19800DB	2	315	225	255	260	275	230
8		(2) 2x SDWS22800DB	2	345	240	275	360	275	345
5		Top Plate	(2) 2x SDWS22500DB	2	345	240	275	360	275
6	(2) 2x SDWH19600DB		2	315	225	255	260	275	230
6	(2) 2x SDWS22600DB		2	345	240	275	360	275	345

- Allowable loads are shown at the wood load duration factor of  $C_D = 1.00$ . Loads may be increased for load duration by the building code up to a  $C_D = 1.60$ .
- For 2x solid sawn members and 1 ¼" LVL or LSL members the minimum edge distance is 5/8". For 1 ¾" LVL or LSL members the minimum edge distance is 7/8".
- Wood structural panel up to 1 ½" thick (2 ¾" for 4" fasteners) is permitted between sole plate and rim board provided it is fastened to the rim board per code and the minimum penetration of the screw into the rim/block is met.
- Double sole plate and top plate fastened minimum per code.
- Minimum rim height is 9 ¼" when using fasteners on the top and bottom. Sole to blocking loads can be achieved with or without a wall below.
- For assemblies using SPF/HF lumber for the sole plate, top plate, or rim/blocking members, multiply table values by 0.86.

### Spacing for Multiple Rows of Fasteners

Material	O.C. Spacing/ End Distance Spacing (in.)	Row Offset (in.)	Row Stagger (in.)
Solid Sawn	3	1 ¼	1 ¼
	6		
LVL or LSL	4	1 ¼	1 ¼
	6	1 ¼	1 ¼

- The material must be wide enough to accommodate minimum edge distance, row offset and row stagger.

# Deck Construction — Ledgers

## Strong-Drive® SDWH TIMBER-HEX Screw

For more information, see p. 55, C-F-2019 Fastening Systems Catalog

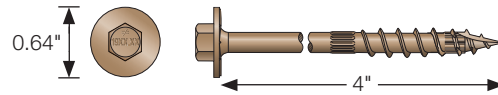

### SDWH — 2015 and 2018 IRC Compliant Spacing for a Sawn Lumber Deck Ledger-to-Rim Board

Loading Condition	Nominal Ledger Size	Size (in.)	Model No.	Rim Board Material and Minimum Size	Maximum Deck Joist Span						
					Up to 6 ft.	Up to 8 ft.	Up to 10 ft.	Up to 12 ft.	Up to 14 ft.	Up to 16 ft.	Up to 18 ft.
					Maximum On-Center Spacing of Fasteners (in.)						
40 psf Live 10 psf Dead	2x	0.195 x 4	SDWH19400DB	1" OSB	13	9	8	6	5	5	4
				1" LVL							
				1 1/8" OSB	18	13	11	9	8	7	6
				1 5/16" LVL							
				1 1/4" LSL							
2x SP, DFL — 2x SPF, HF	15	12	9	8	7	6	5				
60 psf Live 10 psf Dead	2x	0.195 x 4	SDWH19400DB	1" OSB	9	7	5	5	4	—	—
				1" LVL							
				1 1/8" OSB	13	10	8	6	5	5	4
				1 5/16" LVL							
				1 1/4" LSL							
2x SP, DFL — 2x SPF, HF	11	8	7	6	5	4	4				

- SDWH screw spacing values are equivalent to 2018 IRC Table R507.9.1.3(1) and 2015 IRC table R507.2. The table above also provides SDWH screw spacing for a wider range of materials commonly used for rim board, and an alternate loading condition as required by some jurisdictions.
- Solid sawn rim board shall be Spruce-Pine-Fir, Hem-Fir, Douglas Fir-Larch, or Southern Pine species. Ledger shall be Hem-Fir, Douglas Fir-Larch, or Southern Pine species.
- Fastener spacings are based on the lesser of single fastener ICC-ES AC233 testing of the Strong-Drive SDWH screw with a safety factor of 5.0 or ICC-ES AC13 assembly testing with a factor of safety of 5.0. Spacing includes NDS wet service factor adjustment.

- Rows of screws shall be vertically offset and evenly staggered. Screws shall be placed 1 1/2" to 2" from the top and bottom of the ledger or rim board with 3" minimum and 6" maximum between rows and spaced per the table. End screws shall be located 6" from the end and at 1 1/2" to 2" from the bottom of the ledger. For screws located at least 2" but less than 6" from the end, use 50% of the load per screw and 50% of the table spacing between the end screw and the adjacent screw, and for screws located between 2" and 4" from the end, predrill using a 1.8" drill.
- Structural sheathing between the ledger and rim board shall be a maximum of 1/2" thick and fastened per code.

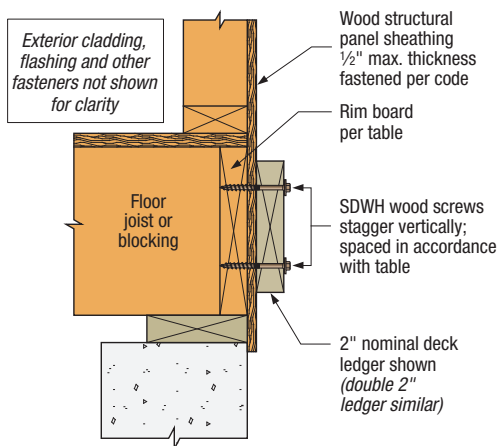

#### Ledger-to-Rim Board Assembly

(wood-framed lower floor acceptable, concrete wall shown for illustration purposes; other fasteners not shown for clarity)

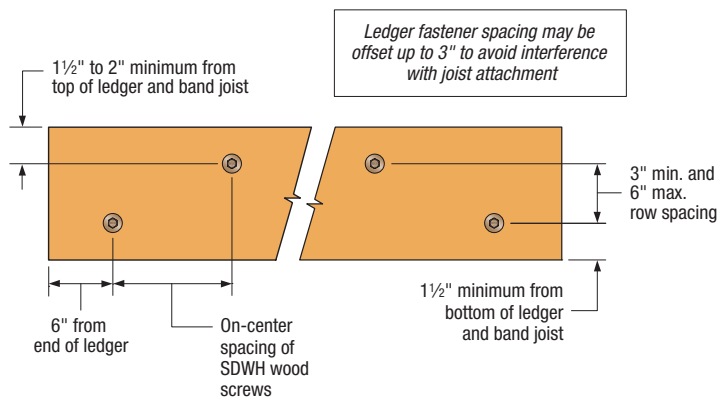

#### SDWH Timber-Hex Screw Spacing Detail

# Deck Construction — Ledgers

## **Strong-Drive®** SDWH **TIMBER-HEX** and SDWS **TIMBER** Screw

2015 and 2018 IRC Compliant Spacing and Allowable Shear Loads  
for Fastening a Sawn Lumber Deck Ledger-to-Rim Board with 1/2" Gap

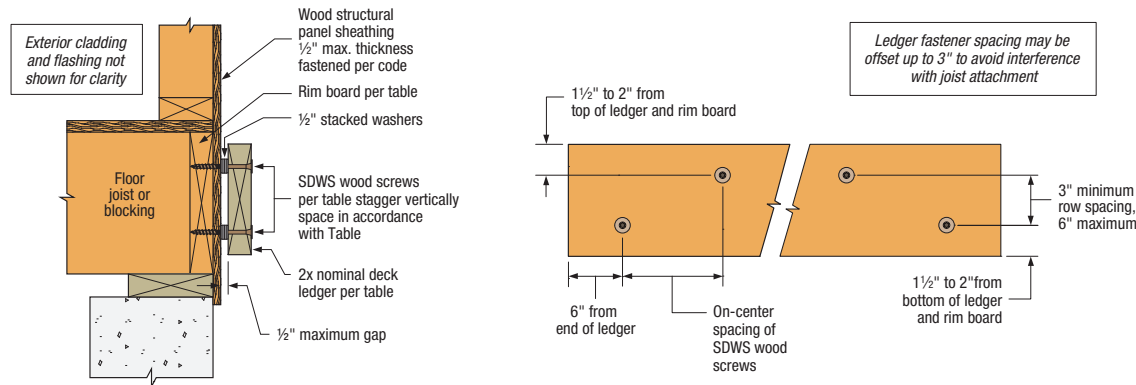

Table below lists the allowable shear loads for SDWS Timber screws and SDWH Timber-Hex screws when attaching a 2x ledger with up to 1/2" thickness of stacked washers to the listed rim board.

### Single-Fastener Allowable Shear Loads for Fastening a Sawn Lumber Deck Ledger-to-Rim Board with 1/2" Gap

Nominal Ledger Size (in.)	Rim Board	Size (in.)	Model No.	Reference Allowable Load (lb.)
2x	2x SPF, DFL, SP #2	0.220 x 4	SDWS22400DB	270
		0.195 x 4	SDWH19400DB	260
	1 1/8" LSL	0.220 x 4	SDWS22400DB	255
		0.195 x 4	SDWH19400DB	245
	1 3/4" LVL	0.220 x 4	SDWS22400DB	290
		0.195 x 4	SDWH19400DB	255

- Sawn Lumber 2x ledger shall have a minimum specific gravity of 0.42 (HF or SPF) and be grade No. 2 or better.
- Rim board is to be dry lumber (specific gravity at least 0.42) or EWP rim board product (equivalent specific gravity of at least 0.42 for nails and screws installed in the face orientation).
- Fastener spacings are based on the lesser of single fastener testing following ICC-ES AC233 or ledger assembly testing following ICC-ES AC13 using a safety factor of 5.0.
- Screws shall be placed 1 1/2" to 2" from the top and bottom of the ledger board or rim board, 6" from the end of the ledger with 3" minimum and 6" maximum between rows. Minimum on-center spacing is 4".
- Wood structural panel sheathing between the ledger and rim board shall be a maximum of 1/2" thick and fastened per code.
- Screws shall be tightened such that the washer stack is tightly compressed between the ledger and the rim board.
- Maximum 1/2" gap created by stacked hot-dip galvanized or stainless-steel 5/16" Type A plain washers (N-narrow) with an outside diameter equal to 0.688" and inside diameter equal to 0.344".
- Allowable loads are shown at the wood load duration factor of  $C_D = 1.0$ . Loads may be increased for load duration per the building code up to a  $C_D = 1.6$ . Tabulated values must be multiplied by all applicable adjustment factors per the NDS, including wet service factor.

## Deck Construction — Ledgers

### Strong-Drive® SDWH TIMBER-HEX and SDWS TIMBER Screw (cont.)

#### 2015 and 2018 IRC Compliant Spacing and Allowable Shear Loads for Fastening a Sawn Lumber Deck Ledger-to-Rim Board with ½" Gap

Strong-Drive® SDWS Timber screws and SDWH Timber-Hex screws are suitable for installing ledgers with up to ½" drainage gap between the ledger and the rim board. These fasteners do not require predrilling and have a double-barrier coating providing corrosion resistance equivalent to hot-dip galvanization. The gap is formed by stacking hot-dip galvanized or stainless-steel ⅝" Type A plain washers (0.688" outside diameter, 0.344" inside diameter) on the shank of the screws between the ledger and the rim board. Weather proofing shall be the responsibility of the installer. The table below lists the maximum on-center spacing of SDWS Timber screws and SDWH Timber-Hex screws when attaching a 2x ledger to the listed rim board of various widths with a maximum ½" gap between them.

#### Loading Condition: 40 PSF Live Load and 10 PSF Dead Load

Ledger Nominal Size (in.)	Rim Board Material (in.)	Size (in.)	Model No.	Maximum Deck Joist Span						
				Up to 6 ft.	Up to 8 ft.	Up to 10 ft.	Up to 12 ft.	Up to 14 ft.	Up to 16 ft.	Up to 18 ft.
				Maximum On-Center Spacing of Fasteners (in.)						
2x	2x DFL, SP, SPF #2	0.220 x 4	SDWS22400DB	15	11	9	7	6	5	5
		0.195 x 4	SDWH19400DB	14	11	8	7	6	5	4
	1.125" LSL	0.220 x 4	SDWS22400DB	14	10	8	7	6	5	4
		0.195 x 4	SDWH19400DB	13	10	8	6	5	5	4
	1.75" LVL	0.220 x 4	SDWS22400DB	16	12	9	8	7	6	5
		0.195 x 4	SDWH19400DB	14	10	8	7	6	5	4

- Sawn lumber ledger shall have minimum specific gravity of 0.42 (HF or SPF) and shall be grade No. 2 or better. Rim board is to be dry lumber (specific gravity at least 0.42) or EWP rim board product (equivalent specific gravity of at least 0.42 for nails and screws installed in the face orientation).
- Fastener spacings are based on the lesser of single fastener testing following ICC-ES AC233 or ledger assembly testing following ICC-ES AC13 using a safety factor of 5.0. Spacing includes NDS wet service factor adjustment.
- Screws shall be placed 1½" to 2" from the top and bottom of the ledger board or rim board, 6" from the end of the ledger with 3" minimum and 6" maximum between rows. End screws shall be located near the bottom of the ledger. See figure on the following page.
- Wood structural panel sheathing between the ledger and rim board shall be a maximum of ½" thick and fastened per code.
- Screws shall be tightened such that the washer stacks are tightly compressed between the ledger and the rim board.
- Maximum ½" gap formed by stacked hot-dip galvanized or stainless-steel ⅝" Type A plain washers (N-narrow) with a nominal outside diameter of 0.688" and inside diameter of 0.344".
- The fastener specifications in this table meet the prescriptive deck ledger attachment solutions and loading requirements per 2018 IRC Table R507.9.1.3(1) and Table R507.2 of the 2012 and 2015 IRC.